

SINGER®

a MUELLER brand

FULL PRODUCT GUIDE – WATERWORKS

Real Solutions for Real Applications



MUELLER

SINGER® PRODUCT CATALOGUE

Table of Contents

About Us – Water Loss Specialists	4
Corporate Social Responsibility.....	5
Discover the Singer® Difference.....	6
Regulatory Approvals.....	7
Limited Warranty.....	8

MAIN VALVES

106 / S106-PG	Single Chamber, Hydraulically Operated Valve.....	12
206 / S206-PG	Single Chamber, Hydraulically Operated Valve.....	20
106 / S106-PT / PTC	Double Chamber, Hydraulically Operated Valve.....	28
206 / S206-PT / PTC	Double Chamber, Hydraulically Operated Valve.....	36
106 / S106-PGM	Integral Back-Up, Dual Diaphragm, Automatic Control Valve.....	44
206 / S206-PGM	Integral Back-Up, Dual Diaphragm, Automatic Control Valve.....	53

MAIN VALVES – OPTIONS

106 / 206-GE	Grooved Ends.....	62
106 / S106-PG	Stainless Steel, Single Chamber, Hydraulically Operated Valve.....	65
106 / 206-IDC	Internal Drop Check.....	70
106 / 206-NYM	No Yellow Metal.....	71
106 / 206-RW	Reclaimed Water Valve.....	72
X107	Position Indicator.....	72
X156	Linear Inductive Valve Position Transmitter.....	74
OX	Oxy-Nitride Stem.....	75
X129	Limit Switch Indicator.....	76
106-AC	Anti-Cavitation Control Valve.....	78

PRESSURE REDUCING

106 / 206-PR-SM	Pressure Reducing Control with Integral Backup.....	90
106 / 206-PFC	Pressure Flow Control (Modulation) Valve.....	93
106 / 206-PR	Pressure Reducing Valve.....	96
106 / 206-PR-48	Pressure Reducing Valve with Low Flow By-Pass.....	99
106 / 206-PR-C	Pressure Reducing and Check Valve.....	102
106 / 206-PR-R	Pressure Reducing and Pressure Sustaining Valve.....	105
106 / 206-PR-S	Pressure Reducing Valve with Downstream Surge Protection.....	108
106 / 206-PR-SC	Pressure Reducing Valve with Solenoid Shut Off.....	111
106 / 206-2PR-630	Pressure Management Valve.....	114

RELIEF / SUSTAINING / SURGE

106 / 206-RPS	Pressure Relief Valve.....	118
106 / 206-RPS	Pressure Sustaining Valve.....	121
106 / 206-RPS-D	Pressure Differential Sustaining Valve.....	124
106 / 206-RPS-L&H	Surge Anticipating Relief Valve.....	127
106 / 206-RPS-RR	Surge Anticipating on Rate of Rise of Pressure Relief Valve.....	130
A106-DL Spring	Dynamic Lifter® Spring Pressure Relief.....	133
A106-DL-Air /		
A106-DL-ET	Dynamic Lifter Air Operated Pressure Relief Valve.....	136

PRODUCT CATALOGUE

Table of Contents

PUMP CONTROL

106 / 206-PG-BPC	In-line Booster Pump Control Valve (Single Chamber)	142
106 / 206-BPC	In-line Booster Pump Control Valve (Double Chamber).....	145
106 / 206-DW	Bypass Deep Well Pump Control Valve (Double Chamber)	148
106 / 206-HC	Hydraulic Check Valve.....	151

LEVEL CONTROL

106 / 206-A-Type 1	Two-Way Flow Altitude Control Valve	156
106 / 206-A-Type 2	One-Way Flow Altitude Control Valve	159
106 / 206-A-Type 3	Two-Way Flow Altitude Control Valve with Differential Control	162
106 / 206-A-Type 4	One-Way Flow Altitude Control Valve with Differential Control	165
106 / 206-F-Type 4	Modulating Float Valve	168
106 / 206-F-Type 5	Non-Modulating Float Valve	171

FLOW CONTROL

106 / 206-RF	Flow Limiting Control Valve.....	176
106 / 206-EF-8837BX	Excess Flow (Burst Control)	179

ELECTRONIC CONTROL

106 / 206-SC	Solenoid Control Valve	184
106 / 206-2SC-PCO	Dual Solenoid Control for Positioning and SCADA Controls.....	187
106 / 206-2PR-SC-BT	Dual Adjustable Set Point Pressure Reducing Valve using Solenoid Control	190
106-SPI-MV	Single Point Insertion Flow Metering Valve	192
106 / 206-2SC-MV	Electronic Flow Control and Metering Valve	194
SCP-TP	Single-Process Control Panel Series	197
LCP-TP	Level Control Panel.....	198
MCP-TP	Multi Process Control Panel Series.....	199
SAP	SAP Panel for Model RPS-L&H-ET; Surge Anticipator Panel.....	201
SPC	Singer® Pump Control Panel	203
420-DC / 420-AC	Automated Pilot Control.....	205

PILOTS & ACCESSORIES

160	Pressure Reducing Pilot (Normally Open).....	208
160-RF	Rate of Flow Pilot (Normally Open)	209
81-RP	Pressure Relief Pilot (Normally Closed)	210
83-RP	High Pressure Relief Pilot (Normally Closed)	211
81-RPD	Differential Pressure Relief Pilot (Normally Closed)	212
301-4	Altitude Pilot Valve.....	213

PRODUCT CATALOGUE

Table of Contents

R-400	Modulating Float Pilot	214
34	Modulating Float Pilot with Vertical Rod	215
35	SST Modulating Float Pilot.....	216
39	Non-Modulating Float Pilot with Vertical Rod	217
43	Rotary Float Pilot (On / Off) with Vertical Rod.....	218
106-RD	Differential Relief Pilot (Normally Closed).....	220
625-RPD	Differential Pilot (Normally Closed).....	221
82-PR	Pilot (Normally Open).....	222
Model 167	Proportional pilot.....	223
Model Jo223A	Building Trades Reducing Pilot.....	224
SST / Braided Hose	Stainless Steel Hose / Stainless Steel Braided Hose.....	225
Model 26	Operating Speed Control.....	226
Fixed Restriction	227
852-B	Needle Valve Speed Control	228
	Micrometer Needle Valves.....	228
	Micrometer Flow Control Valves	228
10 & 12	Pilot Check Valves	228
Jo098B / Jo097B	Strainers.....	229
J1521G / J1521M	Arion Strainers.....	230

TECHNICAL & SIZING

106 / 206	232
Cv And Kv Factor & the Straight Line		232
Drooping Portion of The Curves.....		233
When Actual Flow Is Less Than The Value Shown By The Graph.....		233
Operating Ranges	233
106 Series Flow vs. Pressure Drop Curve – Globe Body, Flat Diaphragm		234
106 Series Flow vs. Pressure Drop Curve – Globe Body, Rolling Diaphragm.....		235
106 Series Flow vs. Pressure Drop Curve – Angle Body, Flat & Rolling Diaphragm.....		236
206 Series Flow vs. Pressure Drop Curve – Globe & Angle, Flat & Rolling Diaphragm.....		237
Dynamic Lifter – Sizing Graph Curve		238
Series 106-AC – Anti-Cavitation Valve Curve		239
Cavitation Chart (Inlet vs. Downstream Pressure)		240
Flange Dimensions – Ductile Iron Valves.....		241

ENGINEERING NOTES

242

HOW TO ORDER

Ordering Instructions	243
Control Valve & Accessories Order Form.....		244
SPI-MV Order Form	245
420-DC / 420-AC Order Form.....		246

Product names, logos, brands, and other trademarks featured or referred to within the Singer® Product Catalogue are the property of their respective trademark holders.

SINGER®

a **MUELLER** brand

WATER IS ESSENTIAL FOR LIFE.

According to the International Water Association's 2010 World Water Congress, 60 percent of the world's population within the next generation will live in cities or urban areas, requiring massive water and energy services and infrastructure. Water loss in potable water distribution systems is also a significant issue. In the United States, for example, the associated cost of lost water is estimated at \$15 billion (US) per year. System losses are influenced by a variety of factors including transmission line material and the age of the piping infrastructure with resulting water losses between 15 to 70 percent being quite common worldwide. Another key challenge is sanitation and waste water management in developed and developing countries.

Because water is essential for life, water conservation, water loss management and waste water management are absolutely critical

to help quench the world's demand for water.

We are committed to conserving water. Since 1957, our pilot operated diaphragm control valves have been installed on virtually every continent around the world. Whether it is water loss management in Southeast Asia, water conservation concerns in Saudi Arabia or urban distribution demands in the United States, we provide water loss management solutions to governments, cities, companies and contractors around the world.

Many of the innovative products we offer are ones that have been born out of our inherent desire to solve unique water loss challenges. Presented with a problem, our team of electronic, instrumentation and control valve specialists are relentless in their research and design until they know a solution works.

SOME OF OUR INNOVATIVE WATER LOSS MANAGEMENT VALVES INCLUDE:

MODEL 106 / 206-PR

Standard Pilot Operated Pressure Reducing Valve (refer to page 98)



- One adjustable set-point
- Ideal for most pressure ranges
- Virtually stable low flow

MODEL 420-DC / 420-AC

SCADA Operated Control Valve (refer to page 206)



- Allows remote adjustment of pilot
- Fail safe operation
- Predictable, repeatable accuracy

MODEL 2PR-630

Pressure Management Valve (refer to page 93)



- Substantially reduces water loss
- Decreases downstream pipe bursts and associated repair costs
- A simple package that saves water loss and money

MODEL 2PR-SC-BT

Dual Adjustable Set-Point Pressure Reducing Valve (refer to singervalve.com)



- Two adjustable set-points for high and low pressure
- Time-based selection via latching solenoid and timer

MODEL PR-8761A

Extremely Low Supply Pressure Reducing Valve (refer to singervalve.com)



- Maintains virtually constant downstream pressure regardless of fluctuations in supply pressure or flow
- High capacity pilot provides optimum modulation as required
- Hydraulically operated – no electrical requirements

ABOUT US

Corporate Social Responsibility

OUR VISION

To be the preferred provider of the most innovative, reliable water control solutions in the world.

OUR MISSION

We are innovative designers and manufacturers of high quality differentiated control valves with excellent technical support and service to our customers.

OUR COMMITMENT TO THE ENVIRONMENT

We care about the environment. After all, we're in the water conservation business, assisting water utilities worldwide to reduce water loss and leakage. But, our concern goes beyond our products and solutions. We are committed to implementing sustainable manufacturing processes and environmentally-friendly office practices on a daily basis. Why? Just as every drop of water counts toward conservation, the way we handle every piece of paper, every ounce of metal and every liter of oil counts toward preserving and protecting the environment. For us, being green means staying green.

Our efforts include:

- Recycling target materials
- A separating, recovering process of waste fluids
- Reducing, reusing and recycling programs

ABOUT OUR CATALOGUE

This catalogue is printed on paper certified by the Forest Stewardship Council® (FSC®).

FSC® is an independent, non-governmental, not-for-profit organization established in 1993 to promote the responsible management of the world's forest.



ABOUT US

Discover the Singer[®] Difference

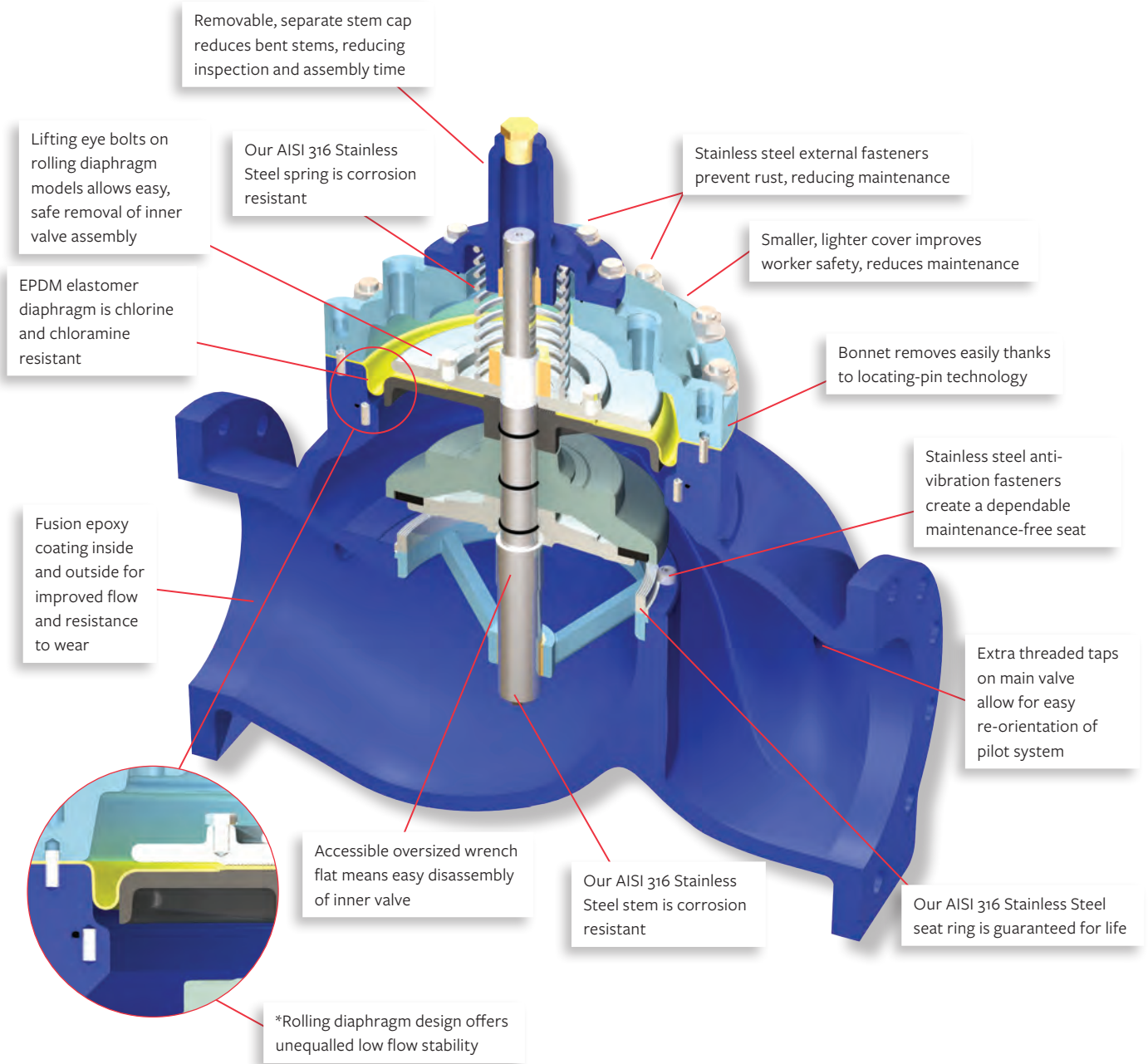

Valve Sizes: ½" to 40" / 15 mm to 1000 mm

Flows from: 0.5 to 55,470 USGPM / 0.03 to 3,500 L/s

*Not available in all size / model combinations. Consult with us.

All 3D graphics done by:



ABOUT US

Regulatory Approvals

We are proud to hold a wide range of regulatory approvals to meet the requirements of your application.

Not all regulatory requirements are available in all sizes and model combinations. We will provide approval details upon request.

Regulatory requirements must be specified at time of order for correct processing and labelling. Processing fees may apply.

Our castings are based on ANSI Class 150 or 300 standards and drilled as per ANSI B16.42 or threaded NPT. Class 150 are machined flat faced while class 300 are machined raised face. ANSI standard dimension are presented in this catalogue in US Units (inches) and Metric Units (millimeters). Also available are ANSI flanges drilled to ISO 7005-2 / BS4504 PN10, PN16, PN25, PN40, or threaded BSPT. ISO standard dimensions are presented in this catalogue in US Units (inches) and Metric Units (millimeters). Australian Standard AS4087 machined to Class 16 or Class 35.



ABOUT US

Limited Warranty

This limited warranty replaces and supersedes all other warranties previously given. All products (the “Products”) manufactured by us (“Seller”) are warranted for THREE YEARS (the “Warranty Period”) from date of purchase (as confirmed by invoice) against manufacturing defects in material and workmanship which develop in the service for which the Products are designed, provided the Products were installed and used in accordance with all applicable instructions and limitations issued by Seller. Seller will, at its sole discretion, repair or replace defective material, free of charge, if returned to Seller’s factory, transportation charges prepaid, provided that, after Seller’s inspection and review, the material is found to have been defective at time of shipment to the Purchaser. Seller is not under any circumstances liable in any respect for any defective Products beyond the Warranty Period.

This warranty is conditional upon the Purchaser giving Seller immediate written notice of discovery of the defect.

Repairs or parts replaced under this warranty are warranted only throughout the remainder of the Warranty Period.

This warranty is in the nature of liquidated damages to which the Purchaser might otherwise be entitled at law or in equity. The Purchaser hereby agrees that, in lieu of any action for fundamental breach of contract or breach of a fundamental term of a contract, it will rely solely on this warranty.

This warranty does not apply to any Product modified or changed in design or function after shipment to the Purchaser, nor to components which are subject to the warranty conditions of another manufacturer. Electronic components used by Seller, manufactured by others, are warranted by their manufacturer for ONE YEAR from date of purchase.

Seller is not under any circumstances, including without limitation, any default, negligence or breach of whatsoever nature by Seller, liable, whether during the Warranty Period or after the Warranty Period, for any claims for labour, installation costs, damages or other special or consequential damages including, but not limited to, loss of revenue or profits, or any other expenses incurred by reason of any Products found to be defective. Seller is not liable for any incidental or consequential loss, damages or expenses (including loss of use) caused by any defects in the Product, by repair of it or arising directly or indirectly from its use. Seller is not liable for any damage or charge for labour or expense in making unauthorized repairs or adjustments to any Product. Seller is not liable for any damage or charges sustained in the adaptation or use of its engineering data and services.

This warranty does not apply if the Product has been altered or repaired by others. Seller will make no allowances or credit for such repairs or alterations unless first authorized in writing by Seller.

No representative of Seller has authority to change any of the foregoing terms or to assume on behalf of Seller any additional liability or responsibility in connection with any Product.

THE FOREGOING WARRANTY IS EXCLUSIVE AND IN LIEU OF ALL OTHER WARRANTIES, CONDITIONS AND REPRESENTATIONS, WHETHER EXPRESS OR IMPLIED, ORAL OR WRITTEN, STATUTORY OR OTHERWISE, INCLUDING, BUT NOT LIMITED TO, ANY IMPLIED WARRANTIES OR CONDITIONS OF MERCHANTABILITY OR FITNESS FOR A PARTICULAR PURPOSE OR DURABILITY. ALL OTHER WARRANTIES, CONDITIONS AND REPRESENTATIONS ARE HEREBY CANCELLED.

ABOUT US

Interested in an Industry Other Than Waterworks?

**CHECK OUT OTHER PRODUCT CATALOGUES AND BROCHURES,
AVAILABLE THROUGH YOUR SINGER® SALES REPRESENTATIVE.**

FIRE PROTECTION CATALOGUE



INDUSTRIAL CONDENSED CATALOGUE

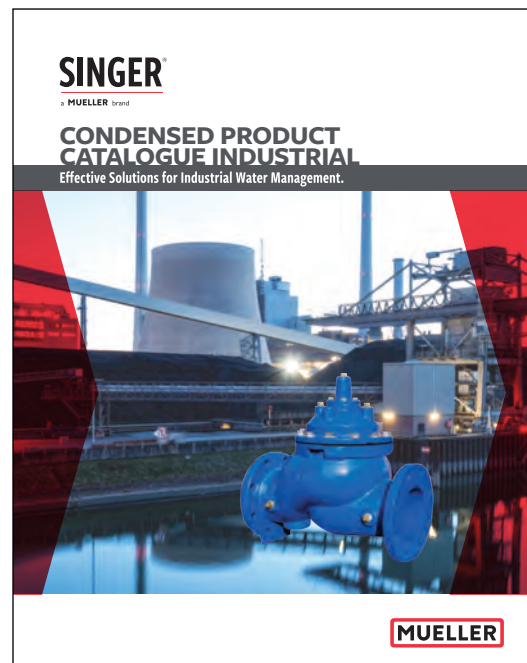

METROH2O

Experience Us in Action. Explore Our Interactive App.



DISCOVER METROH2O ON OUR WEBSITE: SINGERVE.COM

- Interactive software player
- Take a closer look at water systems
- See how valves work in applications
- A great tool for engineers
- Available for download

MAIN VALVES

Everything you've ever wanted in an automatic control valve. We design and manufacture control valves that can handle extreme pressure, sense the slightest danger or call for back-up in emergencies.

Our innovative, patented technology translates into proven solutions for real life applications such as water loss, high pressure drops and inaccurate pressure management. Plagued with cavitation noise and damage? Our double cage anti-cavitation control valve solves both. For precise pressure management, our single rolling diaphragm PR valve is the answer.

MODELS 106-PG / S106-PG

Single Chamber, Hydraulically Operated Valve

KEY FEATURES

- Anti-cavitation option is ideal for high pressure drop situations
- Available in globe and angle style

PRODUCT OVERVIEW

The 106-PG series control valve is designed to suit a large variety of applications such as pressure, flow or level control. This hydraulically operated valve introduces or releases water from the control chamber above the diaphragm to effectively maintain accurate water control

Refer to Main Valve Options on page 62 and Pilots & Accessories on page 207 to further customize the valve to suit specific applications.

PRODUCT LINE DRAWING

ID	PART NAME
1	Removable Stem Cap
2	ASTM A536 Ductile Iron Construction
3	Diaphragm EPDM
4	EPDM Resilient Disc
5	AISI 316 Stainless Steel Seat
6	AISI 316 Stainless Steel Stem
7	NSF 61 Fusion Bonded Epoxy Coating

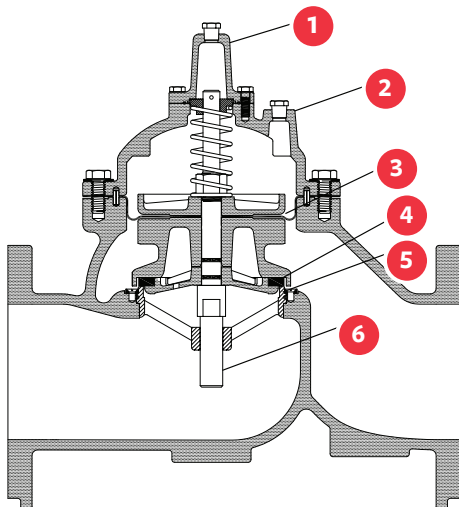

ALTERNATIVE MODELS



A106-PG ANGLE



106-PG THREADED

SELECTION

Automatic control valves operate by introducing or exhausting water from above the diaphragm at controlled rates. A pressure differential is required and is either inlet to outlet or inlet to atmosphere, depending on the application. Valves are sized to provide an appropriate pressure drop for each application. Most valves require a minimum of 10 psi / 0.7 bar pressure drop to operate. This applies mostly to valves that have the bonnet vented to downstream. With minimum of 5 psi / 0.35 bar downstream pressure, many valves can be made to open fully by venting the bonnet to atmosphere.

Our control valves are designed for use with clean potable water. Applications for other media are possible. Consult with us.

Careful consideration of the possibility of cavitation must be given. Anti-cavitation trim is available to control the cavitation, reduce noise

MODELS 106-PG / S106-PG

Single Chamber, Hydraulically Operated Valve

VALVE SIZES & MATERIALS

VALVE STYLES

DUCTILE

STAINLESS STEEL

Available Sizes	Threaded	Flanged	Threaded	Flanged
Globe	1" to 3" (25 - 80 mm)	1 ½" to 36" (40 - 900 mm)	½" to 2" (15 - 50 mm)	1 ½" to 6" (40 - 150 mm)
Angle	1" to 3" (25 - 80 mm)	2" to 12", 16" (50 - 300 mm, 400 mm)	N/A	N/A

VALVE COMPONENTS

DUCTILE

STAINLESS STEEL

	Standard	Optional	Standard	Optional
1. Valve Body, Cover	65-45-12 Ductile Iron	-	316 Stainless Steel	-
2. Seat Ring	316 Stainless Steel	-	316 Stainless Steel	-
3. Disc Retainer	B16 Brass / B62 Bronze / A536 Ductile Iron	316 Stainless Steel	316 Stainless Steel	-
4. Stem	316 Stainless Steel	-	316 Stainless Steel	-
5. Stem Nut	B16 Brass	316 Stainless Steel	316 Stainless Steel	-
6. Spring	316 Stainless Steel	-	316 Stainless Steel	-
7. Guide Bushings	B16 Brass or SAE 660 Bronze	316 Stainless Steel	316 Stainless Steel	-
8. Diaphragm	EPDM	Buna-N / Viton (limited sizes)	EPDM	Buna-N / Viton (limited sizes)
9. Resilient Disc	EPDM	Buna-N / Viton (limited sizes)	EPDM	Buna-N / Viton (limited sizes)
10. Coating	NSF61 Approved Fusion Bonded Epoxy Thickness 10-14 mils (250 - 350 microns)	Consult factory	-	-
11. Fasteners	18-8 Stainless Steel	316 Stainless Steel	18-8 Stainless Steel	316 Stainless Steel

and prevent damage. Refer to 106-AC (page 78) or consult with us.

The 106-PG single chambered valve is the basic valve used in practically every model bearing the 106 description. The pilot systems are designed to meet the functional and performance requirements of specific applications. Sizing is ultimately determined by the specific application.

AVAILABLE OPTIONS

Further customize the valve by adding any of the available options below.

MAIN VALVE OPTIONS, REFER TO PAGE 62

Position Indicators (Available for install at Singer® manufacturing or as a field modification)

- Model X107 stem mounted position indicators
- Model X129 limit switch assembly with Single Pole Double Throw limit switch (Double Pole Double Throw optional)
- Model X156 position transmitter (4 to 20 mA)

Oxy-Nitride Stem

Internal Drop Check

External Spring Lift

PILOTS & ACCESSORIES, REFER TO PAGE 207

MATERIALS OF CONSTRUCTION

Individual components can be upgraded from ductile iron, bronze and brass to stainless steel, for most sizes. Consult with us.

MODEL PGM

Provides a fully operational back-up system in the event of a diaphragm or pilot failure. See page 46.

ANTI-CAVITATION TRIM

Model 106-AC allows very high pressure drops in one valve, while retaining the standard 106 valve features. See page 78.

ORDERING INSTRUCTIONS

Refer to page 244 for the order form and ordering instructions.

Grooved Ends

Reclaim Water

MODELS 106-PG / S106-PG

Single Chamber, Hydraulically Operated Valve

ANSI VALVE DATA (US UNITS)

SIZE	DWG	STANDARD	FLAT DIAPHRAGM SYSTEM												
			INCHES	REF	ANSI	1/2"	3/4"	1"	1 1/4"	1 1/2"	2"	2 1/2"	3"	4"	6"
GLOBE DIMENSIONS			ALL FIGURES SHOWN IN INCHES UNLESS OTHERWISE STATED												
Lay Length	A	FNPT	6.75	6.75	6.75	9.38	11.00	13.50	-	-	-	-	-	-	-
Centerline to Bottom	D	FNPT	2.50	2.50	2.50	2.75	3.38	3.68	-	-	-	-	-	-	-
Lay Length	A	150F	-	-	8.50	9.38	11.00	12.00	15.00	20.00	25.38	-	-	-	-
Centerline to Bottom	D	150F	-	-	2.75	3.00	3.50	3.75	4.60	5.60	7.63	-	-	-	-
Lay Length	A	300F	-	-	9.00	10.00	11.63	13.25	15.63	21.00	26.38	-	-	-	-
Centerline to Bottom	D	300F	-	-	3.25	3.25	3.75	4.13	5.09	6.34	7.88	-	-	-	-
ANGLE DIMENSIONS															
Center Inlet to Discharge	B	FNPT	3.38	3.38	3.38	4.69	5.50	6.63	-	-	-	-	-	-	-
Center Discharge to Inlet	F	FNPT	3.00	3.00	3.00	3.25	4.00	4.63	-	-	-	-	-	-	-
Center Inlet to Discharge	B	150F	-	-	-	4.75	5.50	6.06	7.50	10.00	12.75	-	-	-	-
Center Discharge to Inlet	F	150F	-	-	-	3.25	4.00	4.06	5.00	6.00	8.00	-	-	-	-
Center Inlet to Discharge	B	300F	-	-	-	5.00	5.88	6.43	7.88	10.50	13.25	-	-	-	-
Center Discharge to Inlet	F	300F	-	-	-	3.50	4.31	4.43	5.31	6.50	8.50	-	-	-	-
COMMON DIMENSIONS (GLOBE & ANGLE)															
Width	C		4.88	4.88	6.13	6.50	8.19	9.25	10.88	16.75	21.63	-	-	-	-
Height (To Stem Cap) Globe	E		4.38	4.38	4.38	4.75	7.50	8.00	9.15	11.75	14.91	-	-	-	-
Height (To Stem Cap) Angle	E		4.38	4.38	4.38	4.75	7.50	8.00	9.15	11.75	14.91	-	-	-	-
Body Port Tapping		FNPT	3/8	3/8	3/8	3/8	3/8	3/8	3/8	3/8	1/2	-	-	-	-
Stem Cap Plug		MNPT	3/8	3/8	3/8	3/8	3/8	3/8	3/8	3/8	3/8	-	-	-	-
Cover Port Tapping		FNPT	3/8	3/8	3/8	3/8	3/8	3/8	3/8	1/2	1/2	-	-	-	-
Valve Stroke			1/2	1/2	1/2	9/16	15/16	1 1/8	1 1/16	1 11/16	2 7/8	-	-	-	-
Displaced Bonnet Volume (Gallons)			0.007	0.007	0.007	0.02	0.1	0.1	0.2	0.6	1.7	-	-	-	-
Approximate Shipping Weight (Lbs)			20	20	20	40	65	100	175	400	650	-	-	-	-
FLOW CAPACITIES (USGPM) GLOBE & ANGLE															
C _v - Globe			28	30	32	55	80	110	200	460	800	-	-	-	-
C _v - Angle			24	24	26	63	90	135	230	535	950	-	-	-	-
Continuous (Globe)			49	93	125	210	300	460	800	1800	3100	-	-	-	-
Intermittent (Globe)			61	120	160	260	375	575	1000	2250	3875	-	-	-	-
Momentary (Globe)			110	170	250	470	670	1030	1800	4000	7000	-	-	-	-
MAXIMUM PRESSURE RATINGS (DUCTILE ONLY)															
psi ¹		FNPT	400	400	400	400	400	400	400	-	-	-	-	-	-
psi		150F	-	-	250	250	250	250	250	250	250	-	-	-	-
psi ¹		300F	-	-	400	400	400	400	400	400	400	-	-	-	-
MAXIMUM TEMPERATURE															
Fahrenheit			180°	180°	180°	180°	180°	180°	180°	180°	180°	-	-	-	-

Available in Stainless Steel only. See page 65.

Available in Stainless Steel only. See page 65.

¹Valves rated and stamped 400 psi as standard. Valves rated and stamped 600 psi on request.

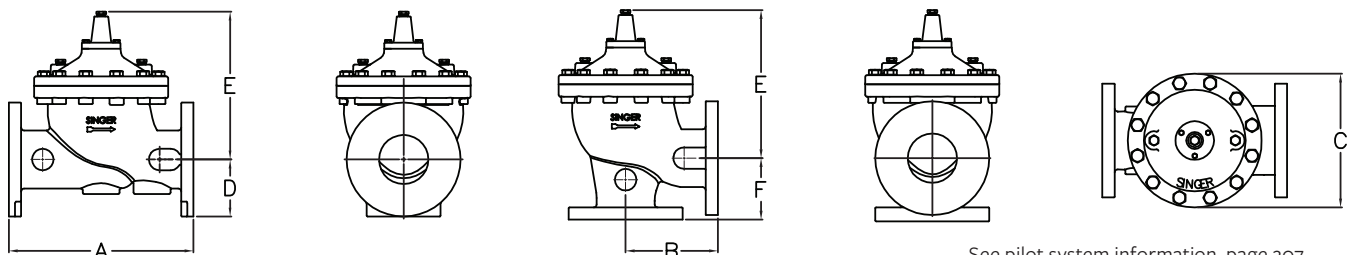

See pilot system information, page 207.
For additional Engineering notes, see page 242.

MODELS 106-PG / S106-PG

Single Chamber, Hydraulically Operated Valve

ANSI VALVE DATA (US UNITS)

SIZE	DWG	STANDARD	ROLLING DIAPHRAGM SYSTEM										
			INCHES	REF	ANSI	6"	8"	10"	12"	14"	16"	20"	24"
GLOBE DIMENSIONS			ALL FIGURES SHOWN IN INCHES UNLESS OTHERWISE STATED.										
Lay Length	A	FNPT	-	-	-	-	-	-	-	-	-	-	-
Centerline to Bottom	D	FNPT	-	-	-	-	-	-	-	-	-	-	-
Lay Length	A	150F	20.00	25.38	29.75	34.00	31.00	41.38	52.00	61.50	76.00		
Centerline to Bottom	D	150F	5.60	7.63	8.56	9.50	10.50	11.75	14.43	17.13	23.50		
Lay Length	A	300F	21.00	26.38	31.12	35.50	32.50	43.50	53.62	63.25	78.00		
Centerline to Bottom	D	300F	6.34	7.88	9.31	10.25	11.50	12.75	15.75	19.65	25.50		
ANGLE DIMENSIONS													
Center Inlet to Discharge	B	FNPT	-	-	-	-	-	-	-	-	-	-	-
Center Discharge to Inlet	F	FNPT	-	-	-	-	-	-	-	-	-	-	-
Center Inlet to Discharge	B	150F	10.00	12.75	11.50	13.75	-	18.00	-	-	-	-	-
Center Discharge to Inlet	F	150F	6.00	8.00	12.50	12.50	-	15.69	-	-	-	-	-
Center Inlet to Discharge	B	300F	10.50	13.25	12.19	14.50	-	18.81	-	-	-	-	-
Center Discharge to Inlet	F	300F	6.50	8.50	13.19	13.25	-	16.50	-	-	-	-	-
COMMON DIMENSIONS (GLOBE & ANGLE)													
Width	C		12.75	16.09	22.13	26.00	26.00	32.00	35.00	49.68	56.00		
Height (To Stem Cap) Globe	E		13.62	17.93	23.31	26.75	26.80	31.40	35.50	45.75	61.00		
Height (To Stem Cap) Angle	E		-	-	20.00	23.75	-	28.50	-	-	-		
Body Port Tapping		FNPT	3/8	1/2	3/4	3/4	3/4	3/4	3/4	3/4	3/4	1	
Stem Cap Plug		MNPT	3/8	3/8	3/4	3/4	3/4	3/4	3/4	3/4	3/4	1	
Cover Port Tapping		FNPT	1/2	1/2	3/4	3/4	3/4	3/4	3/4	3/4	3/4	1	
Valve Stroke			1 11/16	2 7/8	3 1/4	3 3/4	3 3/4	4 3/4	5 9/16	6	9		
Displaced Bonnet Volume (Gallons)			0.50	1.00	1.50	2.30	2.30	6.75	9.00	14.75	43		
Approximate Shipping Weight (Lbs)			350	650	900	1300	1400	2300	3450	5000	13500		
FLOW CAPACITIES (USGPM) GLOBE & ANGLE													
C _v - Globe			460	800	1300	2100	2575	3300	5100	7600	16340		
C _v - Angle			535	950	1400	2450	-	4000	-	-	-		
Continuous (Globe)			1800	3100	4900	7000	8500	11000	17500	25000	55475		
Intermittent (Globe)			2250	3875	6100	8800	11500	14250	21700	31200	69338		
Momentary (Globe)			4000	7000	11000	16000	19000	25000	39000	56200	124700		
MAXIMUM PRESSURE RATINGS (DUCTILE ONLY)													
psi ¹		FNPT	-	-	-	-	-	-	-	-	-	-	-
psi		150F	250	250	250	250	250	250	250	250	250	250	250
psi ¹		300F	400	400	400	400	400	400	400	400	400	400	400
MAXIMUM TEMPERATURE													
Fahrenheit			180°	180°	180°	180°	180°	180°	180°	180°	180°	180°	180°

¹Valves rated and stamped 400 psi as standard. Valves rated and stamped 600 psi on request.

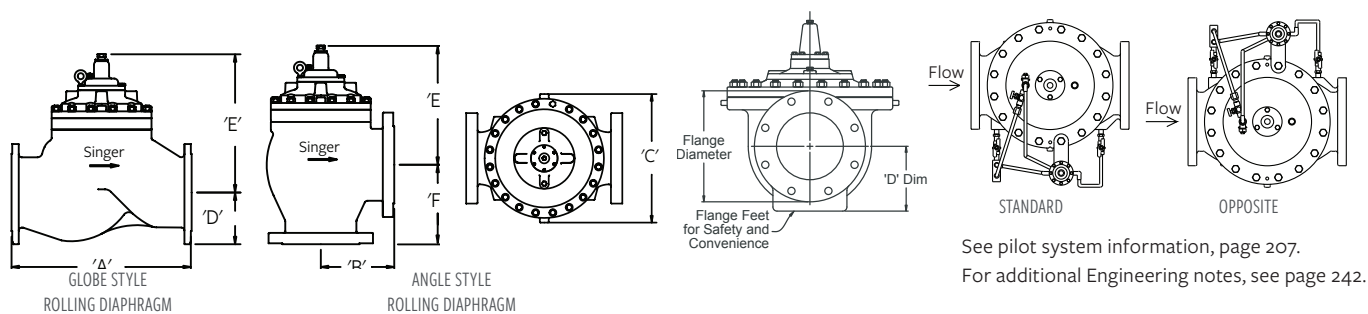

MODELS 106-PG / S106-PG

Single Chamber, Hydraulically Operated Valve

ANSI VALVE DATA (METRIC UNITS)

SIZE	DWG	STND	FLAT DIAPHRAGM SYSTEM												
			MM	REF	ANSI	15 MM	20 MM	25 MM	32 MM	40 MM	50 MM	65 MM	80 MM	100 MM	150 MM
GLOBE DIMENSIONS			ALL FIGURES SHOW IN MM UNLESS OTHERWISE STATED												
Lay Length	A	FNPT			171	171	171	238	279	343	-	-	-	-	-
Centerline to Bottom	D	FNPT			64	64	64	70	86	93	-	-	-	-	-
Lay Length	A	150F			-	-	216	238	279	305	381	508	645		
Centerline to Bottom	D	150F			-	-	70	76	89	95	117	142	200		
Lay Length	A	300F			-	-	229	254	295	337	397	533	670		
Centerline to Bottom	D	300F			-	-	83	83	95	105	129	161	200		
ANGLE DIMENSIONS															
Center Inlet to Discharge	B	FNPT			86	86	86	119	140	168	-	-	-		
Center Discharge to Inlet	F	FNPT			76	76	76	83	102	118	-	-	-		
Center Inlet to Discharge	B	150F			-	-	-	121	140	154	191	254	324		
Center Discharge to Inlet	F	150F			-	-	-	83	102	103	127	152	203		
Center Inlet to Discharge	B	300F			-	-	-	127	149	163	200	267	337		
Center Discharge to Inlet	F	300F			-	-	-	89	109	113	135	165	216		
COMMON DIMENSIONS (GLOBE & ANGLE)															
Width	C				124	124	156	165	208	235	276	425	549		
Height (to stem cap) Globe	E				111	111	111	121	191	203	232	298	379		
Height (to stem cap) Angle	E				111	111	111	121	191	203	232	298	379		
Body Port Tapping	FNPT	Inches			3/8	3/8	3/8	3/8	3/8	3/8	3/8	3/8	1/2		
Stem Cap Plug	MNPT	Inches			3/8	3/8	3/8	3/8	3/8	3/8	3/8	3/8	3/8		
Cover Port Tapping	FNPT	Inches			3/8	3/8	3/8	3/8	3/8	3/8	3/8	1/2	1/2		
Valve Stroke		mm			13	13	13	14	25	29	37	43	73		
Displaced Bonnet Volume (Liters)					0.03	0.03	0.03	0.1	0.3	0.3	0.8	2.1	6.3		
Approximate Shipping Weight (Kilograms)					9	9	9	18	29	45	79	181	295		
FLOW CAPACITIES (L/S) GLOBE & ANGLE															
K _v - Globe (m ³ /h @ 1 bar)					24	26	28	48	69	95	173	398	692		
K _v - Angle (m ³ /h @ 1 bar)					21	21	22	54	78	117	199	463	822		
Continuous (Globe)					3	6	8	13	19	29	50	114	196		
Intermittent (Globe)					4	8	10	16	24	36	63	142	244		
Momentary (Globe)					7	11	16	30	42	65	114	252	442		
MAXIMUM PRESSURE RATINGS (DUCTILE ONLY)															
Bar ¹		FNPT			27.6	27.6	27.6	27.6	27.6	27.6	27.6	-	-	-	
Bar		150F			-	-	17	17	17	17	17	17	17		
Bar ¹		300F			-	-	27.6	27.6	27.6	27.6	27.6	27.6	27.6		
MAXIMUM TEMPERATURE															
Celcius					82°	82°	82°	82°	82°	82°	82°	82°	82°		

Available in Stainless Steel only. See page 80.

Available in Stainless Steel only. See page 80.

¹Valves rated and stamped 27.6 bar as standard. Valves rated and stamped 41 bar on request.

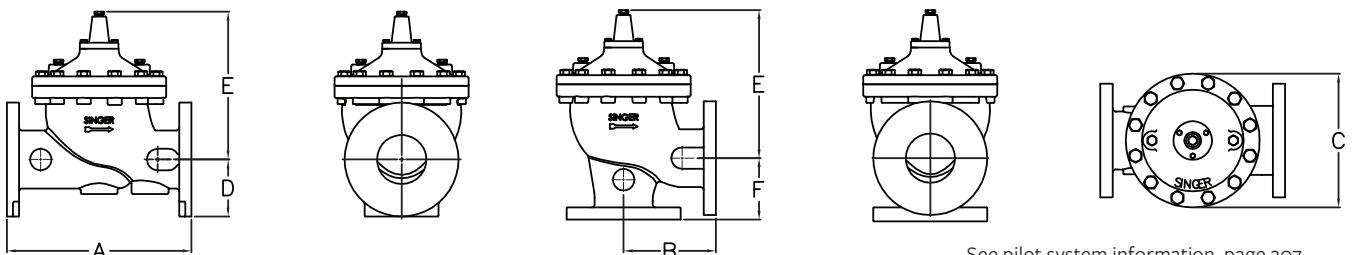

See pilot system information, page 207.
For additional Engineering notes, see page 242.

MODELS 106-PG / S106-PG

Single Chamber, Hydraulically Operated Valve

ANSI VALVE DATA (METRIC UNITS)

SIZE	DWG	STANDARD	ROLLING DIAPHRAGM SYSTEM									
			MM	REF	ANSI	150 MM	200 MM	250 MM	300 MM	350 MM	400 MM	500 MM
GLOBE DIMENSIONS			ALL FIGURES SHOWN IN MM UNLESS OTHERWISE STATED.									
Lay Length	A	FNPT	-	-	-	-	-	-	-	-	-	-
Centerline to Bottom	D	FNPT	-	-	-	-	-	-	-	-	-	-
Lay Length	A	150F	508	645	756	864	787	1051	1321	1562	1930	
Centerline to Bottom	D	150F	142	200	217	241	267	298	367	435	597	
Lay Length	A	300F	533	670	790	902	826	1105	1362	1607	1981	
Centerline to Bottom	D	300F	161	200	236	260	292	324	400	499	648	
ANGLE DIMENSIONS												
Center Inlet to Discharge	B	FNPT	-	-	-	-	-	-	-	-	-	-
Center Discharge to Inlet	F	FNPT	-	-	-	-	-	-	-	-	-	-
Center Inlet to Discharge	B	150F	254	324	292	349	-	457	-	-	-	
Center Discharge to Inlet	F	150F	152	203	318	318	-	399	-	-	-	
Center Inlet to Discharge	B	300F	267	337	310	368	-	478	-	-	-	
Center Discharge to Inlet	F	300F	165	216	335	337	-	419	-	-	-	
COMMON DIMENSIONS (GLOBE & ANGLE)												
Width	C		324	409	562	660	660	813	889	1262	1422	
Height (To Stem Cap) Globe	E		346	455	592	679	681	798	902	1162	1550	
Height (To Stem Cap) Angle	E		-	-	508	603	-	724	-	-	-	
Body Port Tapping	FNPT	Inches	3/8	1/2	3/4	3/4	3/4	3/4	3/4	3/4	3/4	1
Stem Cap Plug	MNPT	Inches	3/8	3/8	3/4	3/4	3/4	3/4	3/4	3/4	3/4	1
Cover Port Tapping	FNPT	Inches	1/2	1/2	3/4	3/4	3/4	3/4	3/4	3/4	3/4	1
Valve Stroke		mm	43	73	83	95	95	120	141	150	229	
Displaced Bonnet Volume (Litres)			2	4	6	9	9	26	34	56	163	
Approximate Shipping Weight (Kilograms)			160	250	480	590	635	1043	1565	2268	6124	
FLOW CAPACITIES (L/S) GLOBE & ANGLE												
K _v - Globe (m ³ /h @ 1 bar)			398	692	1150	1817	2227	2855	4412	6574	14134	
K _v - Angle (m ³ /h @ 1 bar)			463	822	1211	2119	-	3460	-	-	-	
Continuous (Globe)			114	196	309	442	536	694	1104	1577	3500	
Intermittent (Globe)			142	244	385	555	726	899	1370	1968	4375	
Momentary (Globe)			252	442	694	1009	1199	1577	2460	3546	7867	
MAXIMUM PRESSURE RATINGS (DUCTILE ONLY)												
Bar ¹	FNPT		-	-	-	-	-	-	-	-	-	
Bar	150F		17	17	17	17	17	17	17	17	17	
Bar ¹	300F		28	28	28	28	28	28	28	28	28	
MAXIMUM TEMPERATURE												
Celcius			82°	82°	82°	82°	82°	82°	82°	82°	82°	

¹Valves rated and stamped 27.6 bar as standard. Valves rated and stamped 41 bar on request.

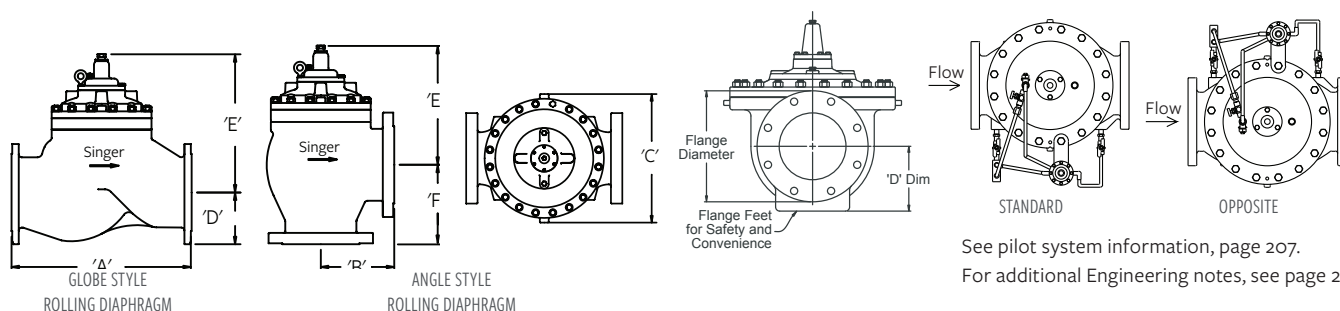

See pilot system information, page 207.

For additional Engineering notes, see page 242.

MODELS 106-PG / 206-PG

Single Chamber, Hydraulically Operated Valve

ANSI VALVE DATA (METRIC UNITS)

SIZE	DWG	STND	FLAT DIAPHRAGM SYSTEM												
			MM	REF	ISO	15 MM	20 MM	25 MM	32 MM	40 MM	50 MM	65 MM	80 MM	100 MM	150 MM
GLOBE DIMENSIONS			ALL FIGURES SHOW IN MM UNLESS OTHERWISE STATED												
Lay Length	A	BSPT			171	171	171	238	279	343	-	-	-	-	-
Centerline to Bottom	D	BSPT			64	64	64	70	86	93	-	-	-	-	-
Lay Length	A	PN10 / PN16			-	-	229	238	279	318	381	508	645		
Centerline to Bottom	D	PN10 / PN16			-	-	83	76	89	100	117	142	200		
Lay Length	A	PN25 / PN40			-	-	229	238	279	318	397	533	670		
Centerline to Bottom	D	PN25 / PN40			-	-	83	76	89	100	129	161	200		
ANGLE DIMENSIONS															
Center Inlet to Discharge	B	BSPT			86	86	86	119	140	168	-	-	-		
Center Discharge to Inlet	F	BSPT			76	76	76	83	102	118	-	-	-		
Center Inlet to Discharge	B	PN10 / PN16			-	-	-	121	140	163	191	254	324		
Center Discharge to Inlet	F	PN10 / PN16			-	-	-	83	102	113	127	152	203		
Center Inlet to Discharge	B	PN25 / PN40			-	-	-	121	140	163	200	267	337		
Center Discharge to Inlet	F	PN25 / PN40			-	-	-	83	102	113	135	165	216		
COMMON DIMENSIONS (GLOBE & ANGLE)															
Width	C				124	124	156	165	208	235	276	425	549		
Height (To Stem Cap) Globe	E				111	111	111	121	191	203	232	298	379		
Height (To Stem Cap) Angle	E				111	111	111	121	191	203	232	298	379		
Body Port Tapping	FNPT	Inches			3/8	3/8	3/8	3/8	3/8	3/8	3/8	3/8	1/2		
Stem Cap Plug	MNPT	Inches			3/8	3/8	3/8	3/8	3/8	3/8	3/8	3/8	3/8		
Cover Port Tapping	FNPT	Inches			3/8	3/8	3/8	3/8	3/8	3/8	3/8	1/2	1/2		
Valve Stroke		mm			13	13	13	14	25	29	37	43	73		
Displaced Bonnet Volume (Liters)					0.03	0.03	0.03	0.1	0.3	0.3	0.8	2.1	6.3		
Approximate Shipping Weight (Kilograms)					9	9	9	18	29	45	79	181	295		
FLOW CAPACITIES (L/S) GLOBE & ANGLE															
K _v - Globe (m ³ /h @ 1 bar)					24	26	28	48	69	95	173	398	692		
K _v - Angle (m ³ /h @ 1 bar)					21	21	22	54	78	117	199	463	822		
Continuous (Globe)					3	6	8	13	19	29	50	114	196		
Intermittent (Globe)					4	8	10	16	24	36	63	142	244		
Momentary (Globe)					7	11	16	30	42	65	114	252	442		
MAXIMUM PRESSURE RATINGS (DUCTILE ONLY)															
Bar ¹		BSPT			27.6	27.6	27.6	27.6	27.6	27.6	27.6	-	-	-	
Bar		PN16			-	-	16	16	16	16	16	16	16		
Bar ¹		PN25			-	-	25	25	25	25	25	25	25		
MAXIMUM TEMPERATURE															
Celcius					82°	82°	82°	82°	82°	82°	82°	82°	82°		

Available in Stainless Steel only. See page 80.

Available in Stainless Steel only. See page 80.

¹Valves rated and stamped 27.6 bar as standard. Valves rated and stamped 41 bar on request.

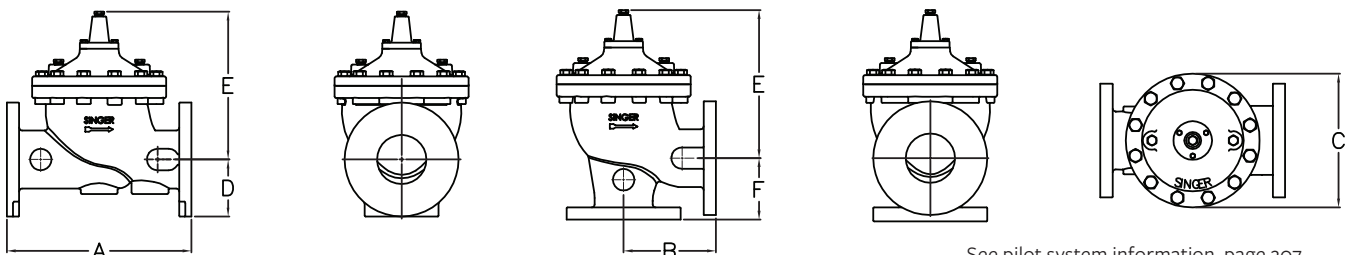

See pilot system information, page 207.
For additional Engineering notes, see page 242.

MODELS 106-PG / S106-PG

Single Chamber, Hydraulically Operated Valve

ISO VALVE DATA (METRIC UNITS)

SIZE	DWG	STANDARD	ROLLING DIAPHRAGM SYSTEM									
			MM	REF	ISO	150 MM	200 MM	250 MM	300 MM	350 MM	400 MM	500 MM
GLOBE DIMENSIONS			ALL FIGURES SHOWN IN MM UNLESS OTHERWISE STATED									
Lay Length	A	BSPT	-	-	-	-	-	-	-	-	-	-
Centerline to Bottom	D	BSPT	-	-	-	-	-	-	-	-	-	-
Lay Length	A	PN10 / PN16	508	645	756	864	787	1051	1321	1562	1930	
Centerline to Bottom	D	PN10 / PN16	142	200	217	241	267	298	367	435	597	
Lay Length	A	PN25 / PN40	533	670	790	864	826	1105	1362	1607	1981	
Centerline to Bottom	D	PN25 / PN40	161	200	243	241	292	324	400	499	648	
ANGLE DIMENSIONS												
Center Inlet to Discharge	B	BSPT	-	-	-	-	-	-	-	-	-	
Center Discharge to Inlet	F	BSPT	-	-	-	-	-	-	-	-	-	
Center Inlet to Discharge	B	PN10 / PN16	254	324	292	349		457				
Center Discharge to Inlet	F	PN10 / PN16	152	203	318	318		399				
Center Inlet to Discharge	B	PN25 / PN40	267	337	310	349		478				
Center Discharge to Inlet	F	PN25 / PN40	165	216	335	318		419				
COMMON DIMENSIONS (GLOBE & ANGLE)												
Width	C		324	409	562	660	660	813	889	1262	1422	
Height (To Stem Cap) Globe	E		346	455	592	679	681	798	902	1162	1550	
Height (To Stem Cap) Angle	E		-	-	508	603		724	-			
Body Port Tapping	FNPT	Inches	$\frac{3}{8}$	$\frac{1}{2}$	$\frac{3}{4}$	$\frac{3}{4}$	$\frac{3}{4}$	$\frac{3}{4}$	$\frac{3}{4}$	$\frac{3}{4}$	1	
Stem Cap Plug	MNPT	Inches	$\frac{3}{8}$	$\frac{3}{8}$	$\frac{3}{4}$	$\frac{3}{4}$	$\frac{3}{4}$	$\frac{3}{4}$	$\frac{3}{4}$	$\frac{3}{4}$	1	
Cover Port Tapping	FNPT	Inches	$\frac{1}{2}$	$\frac{1}{2}$	$\frac{3}{4}$	$\frac{3}{4}$	$\frac{3}{4}$	$\frac{3}{4}$	$\frac{3}{4}$	$\frac{3}{4}$	1	
Valve Stroke		mm	43	73	83	95	95	120	141	150	229	
Displaced Bonnet Volume (Litres)			2	4	6	9	9	26	34	56	163	
Approximate Shipping Weight (Kilograms)			160	250	480	590	635	1043	1565	2268	6124	
FLOW CAPACITIES (L/S) GLOBE & ANGLE												
K_v - Globe (m^3/h @ 1 bar)			398	692	1125	1817	2227	2855	4412	6574	14134	
K_v - Angle (m^3/h @ 1 bar)			463	822	1211	2119	-	346	-	-	-	
Continuous (Globe)			114	196	309	442	536	694	1104	1577	3500	
Intermittent (Globe)			142	244	385	555	726	899	1370	1968	4375	
Momentary (Globe)			252	442	694	1009	1199	1577	2460	3546	7867	
MAXIMUM PRESSURE RATINGS (DUCTILE ONLY)												
Bar		BSPT	-	-	-	-	-	-	-	-	-	
Bar		PN16	16	16	16	16	16	16	16	16	16	
Bar		PN25	25	25	25	25	25	25	25	25	25	
MAXIMUM TEMPERATURE												
Celcius			82°	82°	82°	82°	82°	82°	82°	82°	82°	

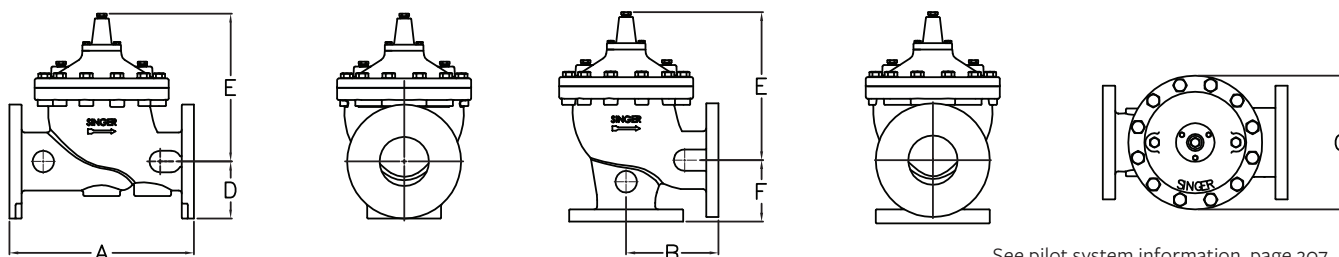

See pilot system information, page 207.
For additional Engineering notes, see page 242.

MODEL 206-PG / S206-PG

Single Chamber, Hydraulically Operated Valve

KEY FEATURES

- Available in globe and angle style

PRODUCT OVERVIEW

The 206-PG series control valve is the preferred choice for pressure reducing valves, flow control valves, relief valves and applications with lower to medium flows. This hydraulically operated valve introduces or releases water from the control chamber above the diaphragm to effectively maintain water control.

Further adapt the valve to provide control for a wide range of functions by selecting from our wide range of pilot and accessories options. Customize for functions like controlling pressure, flow or level or in almost limitless combinations to suit specific applications.



PRODUCT LINE DRAWING

ID	PART NAME
1	Removable Stem Cap
2	ASTM A536 Ductile Iron Construction
3	Diaphragm EPDM
4	EPDM Resilient Disc
5	AISI 316 Stainless Steel Seat
6	AISI 316 Stainless Steel Stem
7	NSF 61 Fusion Bonded Epoxy Coating

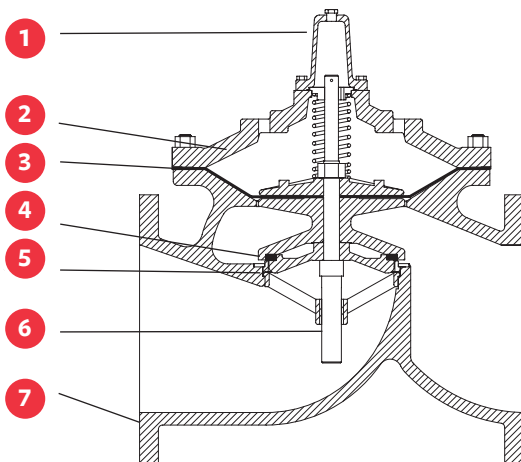

ALTERNATIVE MODELS



A206-PG ANGLE

SELECTION

Automatic control valves operate by introducing or exhausting water from above the diaphragm at controlled rates. A pressure differential is required and is either inlet to outlet or inlet to atmosphere, depending on the application. Valves are sized to provide an appropriate pressure drop for each application. Most valves require a minimum of 10 psi / 0.7 bar pressure drop to operate. This applies mostly to valves that have the bonnet vented to downstream. With minimum of 5 psi / 0.35 bar downstream pressure, many valves can be made to open fully by venting the bonnet to atmosphere.

Singer® control valves are designed for use with clean potable water. Applications for other media are possible. Consult with us.

Careful consideration of the possibility of cavitation must be given. Anti-cavitation trim is available to control the cavitation,

MODEL 206-PG / S206-PG

Single Chamber, Hydraulically Operated Valve

VALVE SIZES & MATERIALS

VALVE MATERIALS

	Standard	Optional
Available Sizes	Flanged	-
Globe	3" to 48" (80 - 1200 mm)	-
Angle	4" to 8" (100 - 200 mm)	-

VALVE COMPONENTS

1. Valve Body, Cover	65-45-12 Ductile Iron	-
2. Seat Ring	316 Stainless Steel	-
3. Disc Retainer	B16 Brass / B62 Bronze / A536 Ductile Iron	316 Stainless Steel
4. Stem	316 Stainless Steel	-
5. Stem Nut	B16 Brass	316 Stainless Steel
6. Spring	316 Stainless Steel	-
7. Guide Bushings	B16 Brass or SAE 660 Bronze	316 Stainless Steel
8. Diaphragm	EPDM	Buna-N / Viton (limited sizes)
9. Resilient Disc	EPDM	Buna-N / Viton (limited sizes)
10. Coating	NSF61 Approved Fusion Bonded Epoxy - Thickness 10-14 mils (250-300 microns)	Consult factory
11. Fasteners	AISI 18-8 Stainless Steel	AISI 316 Stainless Steel

reduce noise and prevent damage. Refer to 106-AC (page 80) or consult with us.

The Singer® Model 206-PG single chambered valve is the basic valve used in practically every model bearing the 206 description. The pilot systems are designed to meet the functional and performance requirements of specific applications. Sizing is ultimately determined by the specific application.

AVAILABLE OPTIONS

Further customize the valve by adding any of the available options below.

MAIN VALVE OPTIONS, REFER TO PAGE 62

Position Indicators (Available for install at Singer® manufacturing or as a field modification)

- Model X107 stem mounted position indicators
- Model X129 limit switch assembly with Single Pole Double Throw limit switch (Double Pole Double Throw optional)
- Model X156 position transmitter (4 to 20 mA)

Oxy-Nitride Stem

Grooved Ends

Internal Drop Check

Reclaimed Water

External Spring Lift

PILOTS & ACCESSORIES, REFER TO PAGE 207

MATERIALS OF CONSTRUCTION

Individual components can be upgraded from ductile iron, bronze and brass to stainless steel, for most sizes. Consult with us.

MODEL PGM

Provides a fully operational back-up system in the event of a diaphragm or pilot failure. See page 46.

ORDERING INSTRUCTIONS

Refer to page 244 for the order form and ordering instructions.

ENGINEERING NOTES, REFER TO PAGE 242

MODEL 206-PG / S206-PG

Single Chamber, Hydraulically Operated Valve

ANSI VALVE DATA (US UNITS)

SIZE	DWG	STANDARD	FLAT DIAPHRAGM SYSTEM					
			INCHES	REF	ANSI	3"	4"	6"
GLOBE DIMENSIONS			ALL FIGURES SHOW IN INCHES UNLESS OTHERWISE STATED					
Lay Length	A	NPT	-	-	-	-	-	-
Centerline to Bottom	D	NPT	-	-	-	-	-	-
Lay Length	A	150F	12.00	15.00	20.13	25.00	24.50	
Centerline to Bottom	D	150F	4.00	4.60	5.62	6.75	8.56	
Lay Length	A	300F	-	15.63	21.00	26.00	25.88	
Centerline to Bottom	D	300F	-	5.00	6.34	7.50	9.31	
ANGLE DIMENSIONS								
Center Inlet to Discharge	B	NPT	-	-	-	-	-	-
Center Discharge to Inlet	F	NPT	-	-	-	-	-	-
Center Inlet to Discharge	B	150F	-	7.56	10.19	12.50	-	-
Center Discharge to Inlet	F	150F	-	5.94	6.19	9.00	-	-
Center Inlet to Discharge	B	300F	-	7.88	10.63	13.00	-	-
Center Discharge to Inlet	F	300F	-	6.25	6.81	9.50	-	-
COMMON DIMENSIONS (GLOBE & ANGLE)								
Width	C		8.19	10.00	12.50	16.00	20.00	
Height (To Stem Cap) Globe	E		7.50	9.62	10.50	14.13	18.63	
Height (To Stem Cap) Angle	E		-	7.75	8.82	11.30	-	
Body Port Tapping		FNPT	$\frac{3}{8}$	$\frac{3}{8}$	$\frac{3}{8}$	$\frac{3}{8}$	$\frac{1}{2}$	
Stem Cap Plug		MNPT	$\frac{3}{8}$	$\frac{3}{8}$	$\frac{3}{8}$	$\frac{3}{8}$	$\frac{3}{8}$	
Cover Port Tapping		FNPT	$\frac{3}{8}$	$\frac{3}{8}$	$\frac{3}{8}$	$\frac{1}{2}$	$\frac{1}{2}$	
Valve Stroke			$\frac{9}{16}$	$1 \frac{1}{8}$	$1 \frac{7}{16}$	$1 \frac{11}{16}$	$2 \frac{7}{8}$	
Displaced Bonnet Volume (Gallons)			0.1	0.1	0.2	0.6	2	
Approximate Shipping Weight (Lbs)			75	100	250	500	650	
FLOW CAPACITIES (USGPM) GLOBE & ANGLE								
C_v - Globe			60	150	250	505	985	
C_v - Angle			-	150	250	560	-	
Continuous (Globe)			300	580	1025	2300	4100	
Intermittent (Globe)			373	690	1190	2700	4670	
Momentary (Globe)			564	1236	2160	4800	8400	
MAXIMUM PRESSURE RATINGS								
psi ¹		FNPT	-	-	-	-	-	
psi		150F	250	250	250	250	250	
psi ¹		300F	400	400	400	400	400	
MAXIMUM TEMPERATURE								
Fahrenheit			180°	180°	180°	180°	180°	

¹Valves rated and stamped 400 psi as standard. Valves rated and stamped 600 psi on request.

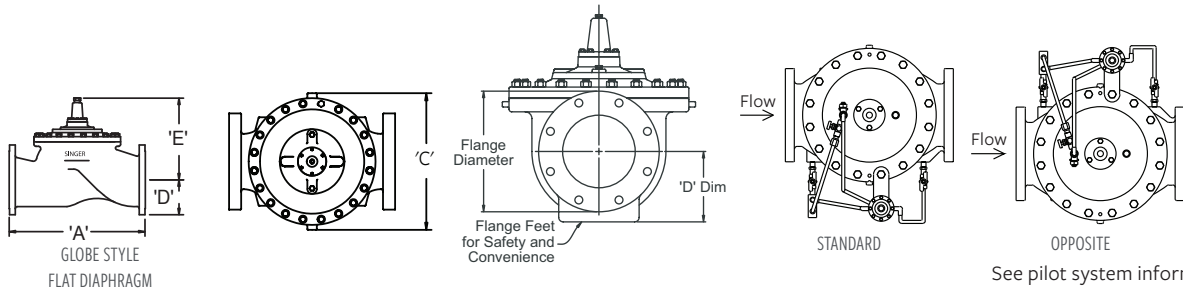

See pilot system information, page 207.
For additional Engineering notes, see page 242.

MODEL 206-PG / S206-PG

Single Chamber, Hydraulically Operated Valve

ANSI VALVE DATA (US UNITS)

SIZE	DWG	STANDARD	ROLLING DIAPHRAGM SYSTEM													
			INCHES	REF	ANSI	8"	10"	12"	16"	18"	20"	24" X 16"	24" X 20"	30"	36"	42"
GLOBE DIMENSIONS			ALL FIGURES SHOWN IN INCHES UNLESS OTHERWISE STATED.													
Lay Length	A	NPT	-	-	-	-	-	-	-	-	-	-	-	-	-	-
Centerline to Bottom	D	NPT	-	-	-	-	-	-	-	-	-	-	-	-	-	-
Lay Length	A	150F	25.00	26.00	27.50	36.00	42.00	45.00	50.50	61.50	69.93	69.93	82	95		
Centerline to Bottom	D	150F	7.00	8.56	9.50	11.75	12.50	13.75	16.50	17.13	20.68	23.75	27	29.75		
Lay Length	A	300F	26.00	27.38	29.00	37.63	43.63	46.63	52.25	63.25	-	-	84.14	97.5		
Centerline to Bottom	D	300F	7.75	9.31	10.25	12.75	14.00	15.25	18.00	19.65	-	-	29	33		
ANGLE DIMENSIONS																
Center Inlet to Discharge	B	NPT	-	-	-	-	-	-	-	-	-	-	-	-	-	-
Center Discharge to Inlet	F	NPT	-	-	-	-	-	-	-	-	-	-	-	-	-	-
Center Inlet to Discharge	B	150F	-	-	-	-	-	-	-	-	-	-	-	-	-	-
Center Discharge to Inlet	F	150F	-	-	-	-	-	-	-	-	-	-	-	-	-	-
Center Inlet to Discharge	B	300F	-	-	-	-	-	-	-	-	-	-	-	-	-	-
Center Discharge to Inlet	F	300F	-	-	-	-	-	-	-	-	-	-	-	-	-	-
COMMON DIMENSIONS (GLOBE & ANGLE)																
Width	C	-	15.00	17.75	22.13	26.00	30.31	31.50	36.00	36.00	49.75	49.75	64.5	64.5		
Height (To Stem Cap) Globe	E	-	14.50	18.88	23.31	26.75	31.38	31.38	31.38	34.46	45.75	45.75	61	61		
Height (To Stem Cap) Angle	E	-	-	-	-	-	-	-	-	-	-	-	-	-	-	-
Body Port Tapping		FNPT	3/8	1/2	3/4	3/4	3/4	3/4	3/4	3/4	3/4	3/4	3/4	1	1	
Stem Cap Plug		MNPT	3/8	3/8	3/4	3/4	3/4	3/4	3/4	3/4	3/4	3/4	3/4	1	1	
Cover Port Tapping		FNPT	1/2	3/8	3/4	3/4	3/4	3/4	3/4	3/4	3/4	3/4	3/4	1	1	
Valve Stroke			1 11/16	1 7/8	3 1/4	3 3/4	4 3/4	4 3/4	4 3/4	5 9/16	6	6	9	9		
Displaced Bonnet Volume (Gallons)			0.5	1.0	1.5	2.3	6.8	6.8	6.8	9.0	14.8	14.8	43	43		
Approximate Shipping Weight (Lbs)			395	715	900	1400	2400	2600	2800	4500	6200	7000	15700	18000		
FLOW CAPACITIES (USGPM) GLOBE & ANGLE																
C _v - Globe			505	985	1550	2200	3300	3400	3500	5100	7800	8000	16340	16340		
C _v - Angle			-	-	-	-	-	-	-	-	-	-	-	-	-	-
Continuous (Globe)			2300	4100	6400	9230	16500	16500	16500	21700	33650	33800	55475	55475		
Intermittent (Globe)			2700	4670	7320	10470	20915	20915	20915	26000	37490	37640	69344	69344		
Momentary (Globe)			4800	8400	13200	19200	30000	30050	30100	39000	67490	67640	124692	124692		
MAXIMUM PRESSURE RATINGS																
psi ¹		FNPT	-	-	-	-	-	-	-	-	-	-	-	-	-	-
psi		150F	250	250	250	250	250	250	250	250	250	250	250	250	250	250
psi ¹		300F	400	400	400	400	400	400	400	400	400	400	400	400	400	400
MAXIMUM TEMPERATURE																
Fahrenheit			180°	180°	180°	180°	180°	180°	180°	180°	180°	180°	180°	180°	180°	180°

¹Valves rated and stamped 400 psi as standard. Valves rated and stamped 600 psi on request.

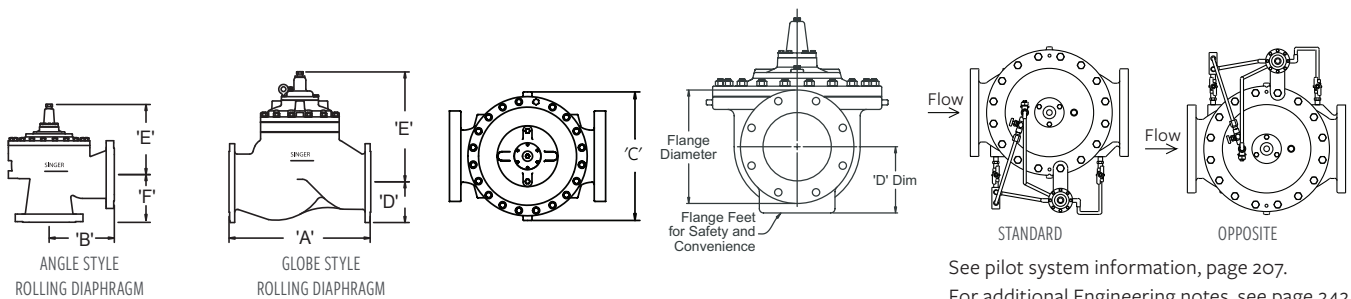

MODEL 206-PG / S206-PG

Single Chamber, Hydraulically Operated Valve

ANSI VALVE DATA (METRIC UNITS)

SIZE	DWG	STANDARD	FLAT DIAPHRAGM SYSTEM				
			80 MM	100 MM	150 MM	200 MM	250 MM
MM	REF	ANSI					
GLOBE DIMENSIONS			ALL FIGURES SHOW IN MM UNLESS OTHERWISE STATED				
Lay Length	A	FNPT	-	-	-	-	-
Centerline to Bottom	D	FNPT	-	-	-	-	-
Lay Length	A	150F	305	381	511	635	622
Centerline to Bottom	D	150F	102	117	143	171	217
Lay Length	A	300F	-	397	533	660	657
Centerline to Bottom	D	300F	-	127	161	191	236
ANGLE DIMENSIONS							
Center Inlet to Discharge	B	FNPT	-	-	-	-	-
Center Discharge to Inlet	F	FNPT	-	-	-	-	-
Center Inlet to Discharge	B	150F	-	192	259	318	-
Center Discharge to Inlet	F	150F	-	151	157	229	-
Center Inlet to Discharge	B	300F	-	200	270	330	-
Center Discharge to Inlet	F	300F	-	159	173	241	-
COMMON DIMENSIONS (GLOBE & ANGLE)							
Width	C		208	254	318	406	508
Height (To Stem Cap) Globe	E		191	244	267	359	473
Height (To Stem Cap) Angle	E		-	197	224	287	-
Body Port Tapping	FNPT	Inches	$\frac{3}{8}$	$\frac{3}{8}$	$\frac{3}{8}$	$\frac{3}{8}$	$\frac{1}{2}$
Stem Cap Plug	MNPT	Inches	$\frac{3}{8}$	$\frac{3}{8}$	$\frac{3}{8}$	$\frac{3}{8}$	$\frac{3}{8}$
Cover Port Tapping	FNPT	Inches	$\frac{3}{8}$	$\frac{3}{8}$	$\frac{3}{8}$	$\frac{1}{2}$	$\frac{1}{2}$
Valve Stroke		mm	14	29	37	43	73
Displaced Bonnet Volume (Liters)			0.3	0.3	0.8	2	6
Approximate Shipping Weight (Kilograms)			34	45	113	227	295
FLOW CAPACITIES (L/S) GLOBE & ANGLE							
K _v - Globe (m ³ /h @ 1 bar)			52	130	216	437	852
K _v - Angle (m ³ /h @ 1 bar)			-	130	216	484	-
Continuous (Globe)			19	37	65	145	259
Intermittent (Globe)			24	44	75	170	295
Momentary (Globe)			36	78	136	303	530
MAXIMUM PRESSURE RATINGS							
Bar		FNPT	-	-	-	-	-
Bar		150F	17	17	17	17	17
Bar ¹		300F	27.6	27.6	27.6	27.6	27.6
MAXIMUM TEMPERATURE							
Celcius			82°	82°	82°	82°	82°

¹Valves rated and stamped 27.6 bar as standard. Valves rated and stamped 41 bar on request.

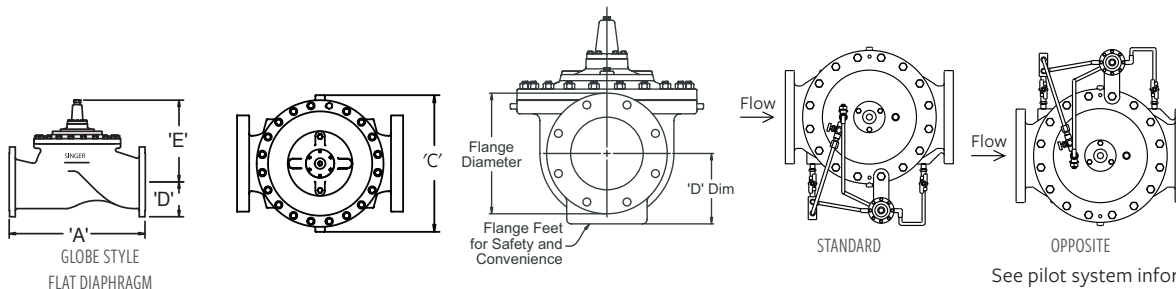

See pilot system information, page 207.
For additional Engineering notes, see page 242.

MODEL 206-PG / S206-PG

Single Chamber, Hydraulically Operated Valve

ANSI VALVE DATA (METRIC UNITS)

SIZE	DWG	STANDARD	ROLLING DIAPHRAGM SYSTEM													
			MM	REF	ANSI	200MM	250MM	300 MM	400 MM	450 MM	500 MM	600 X 400	600 X 500	750 MM	900 MM	1000 MM
GLOBE DIMENSIONS			ALL FIGURES SHOWN IN MM UNLESS OTHERWISE STATED.													
Lay Length	A	FNPT	-	-												
Centerline to Bottom	D	FNPT	-	-												
Lay Length	A	150F	635	660	699	914	1067	1143	1283	1562	1776	1776	1911	2413		
Centerline to Bottom	D	150F	178	217	241	298	318	354	419	435	525	603	641	756		
Lay Length	A	300F	660	695	737	956	1108	1184	1327	1607						
Centerline to Bottom	D	300F	197	236	260	324	356	387	457	499						
ANGLE DIMENSIONS																
Center Inlet to Discharge	B	FNPT	-	-												
Center Discharge to Inlet	F	FNPT	-	-												
Center Inlet to Discharge	B	150F	-	-												
Center Discharge to Inlet	F	150F	-	-												
Center Inlet to Discharge	B	300F	-	-												
Center Discharge to Inlet	F	300F	-	-												
COMMON DIMENSIONS (GLOBE & ANGLE)																
Width	C		381	450	562	660	795	800	914	914	1264	1264	1626	1638		
Height (To Stem Cap) Globe	E		368	480	592	679	797	797	797	875	1162	1162	1550	1549		
Height (To Stem Cap) Angle	E		-	-												
Body Port Tapping	FNPT	Inches	3/8	3/8	3/4	3/4	3/4	3/4	3/4	3/4	3/4	3/4	3/4	1	1	
Stem Cap Plug	MNPT	Inches	3/8	3/8	3/4	3/4	3/4	3/4	3/4	3/4	3/4	3/4	3/4	1	1	
Cover Port Tapping	FNPT	Inches	1/2	1/2	3/4	3/4	3/4	3/4	3/4	3/4	3/4	3/4	3/4	1	1	
Valve Stroke		mm	43	48	83	95	120	120	120	141	150	150	229	229		
Displaced Bonnet Volume (Litres)			2	5	6	9	26	26	26	34	56	56	43	43		
Approximate Shipping Weight (Kilograms)			180	324	408	635	1089	1179	1270	2155	2812	3175	7120	8163		
FLOW CAPACITIES (L/S) GLOBE & ANGLE																
K _v - Globe (m ³ /h @ 1 bar)			120	230	370	520	780	810	830	1210	1850	1870	14134	14134		
K _v - Angle (m ³ /h @ 1 bar)			-	-	-	-	-	-	-	-	-	-	-	-		
Continuous (Globe)			145	259	404	582	1041	1041	1041	1370	2120	2132	3500	3500		
Intermittent (Globe)			170	295	465	661	1320	1320	1320	1640	2362	2375	4375	4375		
Momentary (Globe)			303	530	833	1211	1893	1896	1899	2460	4255	4267	7867	7867		
MAXIMUM PRESSURE RATINGS																
Bar	FNPT		-	-	-	-	-	-	-	-	-	-	-	-		
Bar	150F		17	17	17	17	17	17	17	17	17	17	17	17		
Bar ¹	300F		27.6	27.6	27.6	27.6	27.6	27.6	27.6	27.6	27.5	27.5	27.5	27.5		
MAXIMUM TEMPERATURE																
Celsius			82°	82°	82°	82°	82°	82°	82°	82°	82°	82°	82°	82°		

¹Valves rated and stamped 27.6 bar as standard. Valves rated and stamped 41 bar on request.

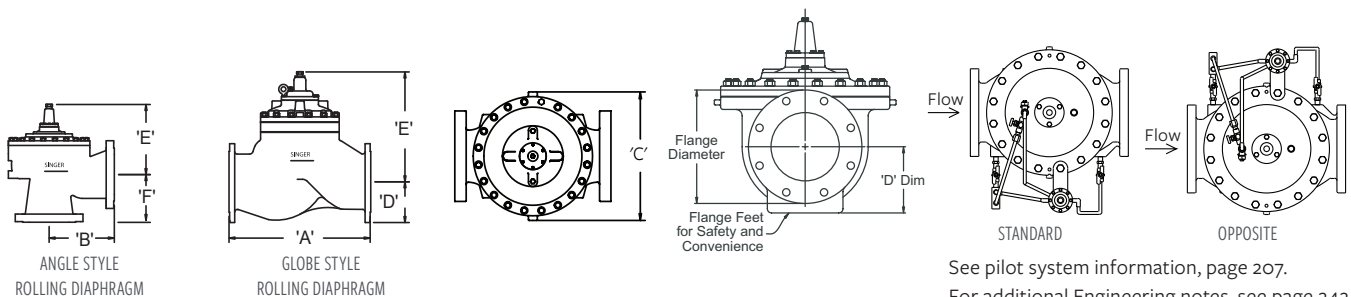

See pilot system information, page 207.
For additional Engineering notes, see page 242.

MODEL 206-PG / S206-PG

Single Chamber, Hydraulically Operated Valve

ISO VALVE DATA (METRIC UNITS)

SIZE	DWG	STANDARD	FLAT DIAPHRAGM SYSTEM				
MM	REF	ISO	80 MM	100 MM	150 MM	200 MM	250 MM
GLOBE DIMENSIONS		BS4504	ALL FIGURES SHOW IN MM UNLESS OTHERWISE STATED				
Lay Length	A	BSPT	-	-	-	-	-
Centerline to Bottom	D	BSPT	-	-	-	-	-
Lay Length	A	PN10 / PN16	305	381	511	635	622
Centerline to Bottom	D	PN10 / PN16	102	117	142	171	217
Lay Length	A	PN25 / PN40	-	397	533	660	657
Centerline to Bottom	D	PN25 / PN40	-	127	161	191	236
ANGLE DIMENSIONS							
Center Inlet to Discharge	B	BSPT	-	-	-	-	-
Center Discharge to Inlet	F	BSPT	-	-	-	-	-
Center Inlet to Discharge	B	PN10 / PN16	-	192	259	318	-
Center Discharge to Inlet	F	PN10 / PN16	-	151	157	229	-
Center Inlet to Discharge	B	PN25 / PN40	-	200	270	330	-
Center Discharge to Inlet	F	PN25 / PN40	-	159	173	241	-
COMMON DIMENSIONS (GLOBE & ANGLE)							
Width	C	-	208	238	318	406	508
Height (To Stem Cap) Globe	E	-	191	244	267	359	473
Height (To Stem Cap) Angle	E	-	-	197	224	287	-
Body Port Tapping	FNPT	Inches	3/8	3/8	3/8	3/8	1/2
Stem Cap Plug	MNPT	Inches	3/8	3/8	3/8	3/8	3/8
Cover Port Tapping	FNPT	Inches	3/8	3/8	3/8	1/2	1/2
Valve Stroke		mm	14	29	37	43	73
Displaced Bonnet Volume (Litres)			0.3	0.3	0.8	2.1	6.3
Approximate Shipping Weight (Kilograms)			34	45	113	227	295
FLOW CAPACITIES (L/S) GLOBE & ANGLE							
K_v - Globe (m ³ /h @ 1 bar)			52	130	216	437	852
K_v - Angle (m ³ /h @ 1 bar)			-	130	216	484	-
Continuous (Globe)			19	37	65	145	259
Intermittent (Globe)			24	44	75	170	295
Momentary (Globe)			36	78	136	303	530
MAXIMUM PRESSURE RATINGS							
Bar		BSPT	-	-	-	-	-
Bar		PN16	16	16	16	16	16
Bar		PN25	25	25	25	25	25
MAXIMUM TEMPERATURE							
Celsius			82°	82°	82°	82°	82°

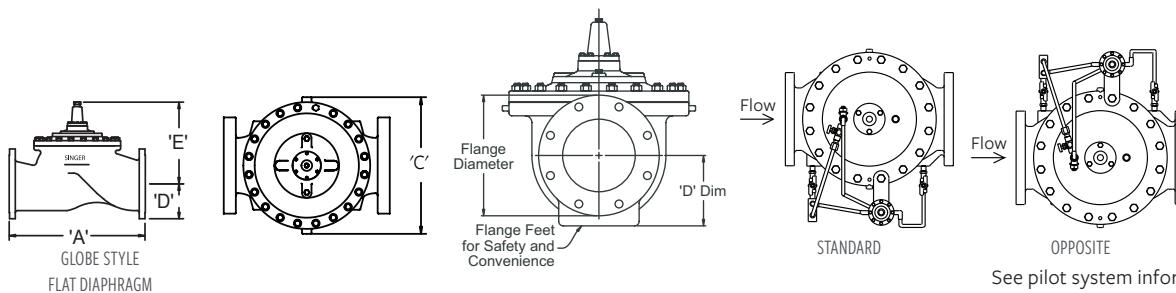

See pilot system information, page 207.
For additional Engineering notes, see page 242.

MODEL 206-PG / S206-PG

Single Chamber, Hydraulically Operated Valve

ISO VALVE DATA (METRIC UNITS)

SIZE	DWG	STANDARD	ROLLING DIAPHRAGM SYSTEM															
			MM	REF	ISO	200MM	250MM	300 MM	400 MM	450 MM	500 MM	600 X 400 MM	600 X 500 MM	700 MM	800 MM	900 MM	1000 MM	1200 MM
GLOBE DIMENSIONS			BS4504			ALL FIGURES SHOWN IN MM UNLESS OTHERWISE STATED.												
Lay Length	A	BSPT	-	-	-	-	-	-	-	-	-	-	-	-	-	-	-	
Centerline to Bottom	D	BSPT	-	-	-	-	-	-	-	-	-	-	-	-	-	-	-	
Lay Length	A	PN10 / PN16	635	660	699	914	1067	1143	1283	1562	1607	1776	1776	1890 / 1911	2413			
Centerline to Bottom	D	PN10 / PN16	178	217	241	298	318	354	419	435	499	526	603	629 / 641	756			
Lay Length	A	PN25 / PN40	660	695	699	956	1108	1184	1327	1607	1607			1930 / ---	2477			
Centerline to Bottom	D	PN25 / PN40	197	236	241	324	356	387	457	499	508			673 / ---	838			
ANGLE DIMENSIONS																		
Center Inlet to Discharge	B	BSPT	-	-	-	-	-	-	-	-	-	-	-	-	-	-	-	
Center Discharge to Inlet	F	BSPT	-	-	-	-	-	-	-	-	-	-	-	-	-	-	-	
Center Inlet to Discharge	B	PN10 / PN16	-	-	-	-	-	-	-	-	-	-	-	-	-	-	-	
Center Discharge to Inlet	F	PN10 / PN16	-	-	-	-	-	-	-	-	-	-	-	-	-	-	-	
Center Inlet to Discharge	B	PN25 / PN40	-	-	-	-	-	-	-	-	-	-	-	-	-	-	-	
Center Discharge to Inlet	F	PN25 / PN40	-	-	-	-	-	-	-	-	-	-	-	-	-	-	-	
COMMON DIMENSIONS GLOBE																		
Width	C		381	450	562	660	800	775	914	914	1262	1262	1262	1624	1638			
Height (To Stem Cap) Globe	E		368	480	592	679	797	797	797	875	1162	1162	1162	1550	1550			
Height (To Stem Cap) Angle	E		-	-	-	-	-	-	-	-	-	-	-	-	-	-	-	
Body Port Tapping	FNPT	Inches	3/8	3/8	3/4	3/4	3/4	3/4	3/4	3/4	3/4	3/4	3/4	3/4	1	1		
Stem Cap Plug	MNPT	Inches	3/8	3/8	3/4	3/4	3/4	3/4	3/4	3/4	3/4	3/4	3/4	3/4	1	1		
Cover Port Tapping	FNPT	Inches	1/2	1/2	3/4	3/4	3/4	3/4	3/4	3/4	3/4	3/4	3/4	3/4	1	1		
Valve Stroke		mm	43	48	83	95	120	120	120	141	150	150	150	229	229			
Displaced Bonnet Volume (Litres)			2	5	6	9	26	26	26	34	56	56	56	163	163			
Approximate Shipping Weight (Kilograms)			180	324	408	635	1089	1179	1270	2155	2721	2993	3175	7120	8163			
FLOW CAPACITIES (L/S) GLOBE																		
K _v - Globe (m ³ /h @ 1 bar)			437	852	1341	1903	2855	2941	3028	4412	6661	6747	6920	14134	14134			
K _v - Angle (m ³ /h @ 1 bar)			-	-	-	-	-	-	-	-	-	-	-	-	-	-	-	
Continuous (Globe)			145	259	404	582	1041	1041	1041	1370	2120	2126	2132	3500	3500			
Intermittent (Globe)			170	295	465	661	1320	1320	1320	1640	2362	2368	2375	4375	4375			
Momentary (Globe)			303	530	833	1211	1893	1896	1899	2460	4255	4261	4267	7867	7867			
MAXIMUM PRESSURE RATINGS																		
Bar		BSPT	-	-	-	-	-	-	-	-	-	-	-	-	-	-	-	
Bar		PN16	16	16	16	16	16	16	16	16	16	16	16	16	16	16	16	
Bar		PN25	25	25	25	25	25	25	25	25	25	25	25	25	25	25	25	
MAXIMUM TEMPERATURE																		
Celcius			82°	82°	82°	82°	82°	82°	82°	82°	82°	82°	82°	82°	82°	82°	82°	

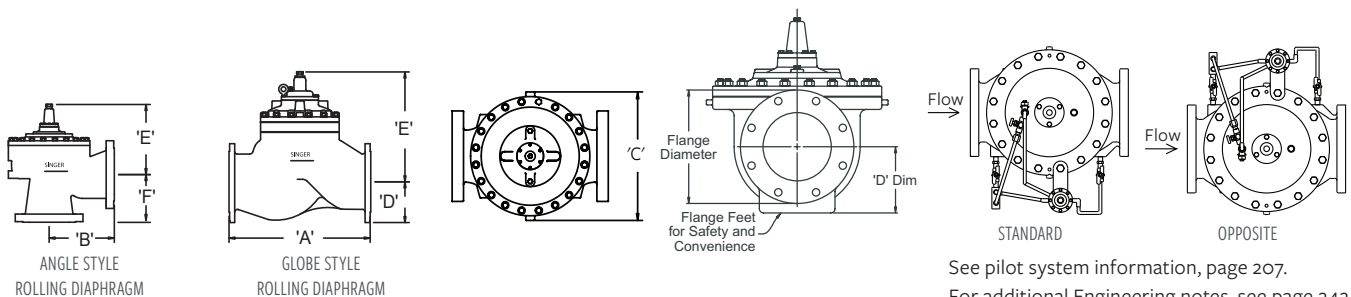

MODEL 106-PT / 106-PTC / S106-PT / S106-PTC

Double Chamber Hydraulically Operated Valve

KEY FEATURES

- Maintains positive control under all operating pressures
- Precise positioning
- Internal drop check option included on the PTC model
- Available in globe and angle style

PRODUCT OVERVIEW

The 106-PT and 106-PTC series control valves are hydraulically operated by introducing or releasing water from the control chambers. PT and PTC valves have two operating chambers that are divided from each other by the diaphragm, and are separated from the flowing media by an adaptor plate.

106-PTC is an enhancement of the 106-PT and includes an internal drop check feature. This mechanical check provides non-slam closure on reverse flow, independently of the stem position or the pilot operation.

PT and PTC valves are usually combined with our specific purpose pilots and accessories to provide control for a wide range of functions: typically pump control and solenoid control applications. Refer to Main Valve Options on page 62 and Pilots & Accessories on page 207 to further customize the valve to suit specific applications and accessories options. Customize for functions like controlling pressure, flow or level or in almost limitless combinations to suit specific applications.



ALTERNATIVE MODELS



A106-PT ANGLE

PRODUCT LINE DRAWING

ID	PART NAME
1	Optional Model X129 Limit Switch Assembly
2	Double Chambers Separated From The Flowing Media
3	ASTM A536 Ductile Iron Construction
4	Diaphragm Buna-N or EPDM
5	Optional Internal Check Feature (for PT series)
6	Buna-N or EPDM Resilient Disc
7	AISI 316 Stainless Steel Seat
8	AISI 316 Stainless Steel Stem
9	NSF 61 Fusion Bonded Epoxy Coating

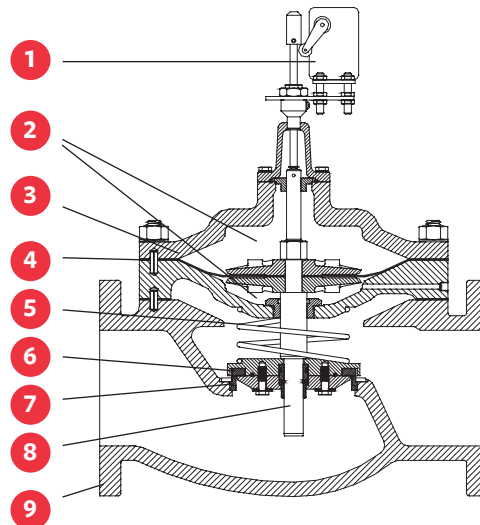

SELECTION

The 106-PT and 106-PTC valves operate by introducing or exhausting water from the upper and lower chambers at controlled rates. Since the operating chambers are separated from the flowing media, a positive and precise differential pressure can be established across the diaphragm. Valves are sized to provide an appropriate pressure drop for each application. Valves usually exhaust to atmosphere

Sizing is ultimately determined by the specific application. Refer to the capacity charts for general guidelines.

MODEL 106-PT / 106-PTC / S106-PT / S106-PTC

Double Chamber Hydraulically Operated Valve

VALVE SIZES & MATERIALS

VALVE MATERIALS

	Standard		Optional
Available Sizes	Threaded	Flanged	-
Globe	2" to 3" (50 - 80 mm)	2" to 24" (50 - 600 mm)	-
Angle	2" to 3" (50 mm - 80 mm)	2" to 12" , 16" (50 - 300 mm, 400 mm)	-

VALVE COMPONENTS

1. Valve Body, Cover	65-45-12 Ductile Iron	316 Stainless Steel (limited sizes)
2. Seat Ring	316 Stainless Steel	-
3. Disc Retainer	B16 Brass / B62 Bronze / A536 Ductile Iron	316 Stainless Steel
4. Stem	316 Stainless Steel	-
5. Stem Nut	B16 Brass	316 Stainless Steel
6. Spring	316 Stainless Steel	-
7. Guide Bushings	B16 Brass or SAE 660 Bronze	316 Stainless Steel
8. Diaphragm	EPDM	Buna-N / Viton (limited sizes)
9. Resilient Disc	EPDM	Buna-N / Viton (limited sizes)
10. Coating	NSF61 Approved Fusion Bonded Epoxy - Thickness 10-14 mils (250-350 microns)	Consult factory
11. Fasteners	18-8 Stainless Steel	316 Stainless Steel

Double-chambered automatic control valves are typically used for pump control. Other uses would include but not be limited to low-pressure differential applications. 106-PT and 106-PTC valves are particularly well suited for applications that require valves to open fully regardless of flow or pressure drop or any application where more relatively constant, controlled speed is required.

AVAILABLE OPTIONS

Further customize the valve by adding any of the available options below.

MAIN VALVE OPTIONS, REFER TO PAGE 62

Position Indicators (Available for install at Singer® manufacturing or as a field modification)

- Model X107 stem mounted position indicators
- Model X129 limit switch assembly with Single Pole Double Throw limit switch (Double Pole Double Throw optional)
- Model X156 analog position transmitters (4 - 20 mA)

Oxy-Nitride Stem

Internal Drop Check

Grooved Ends

Reclaimed Water

PILOTS & ACCESSORIES, REFER TO PAGE 207

MATERIALS OF CONSTRUCTION

Individual components can be upgraded from ductile iron, bronze and brass to stainless steel, for most sizes. Consult with us.

ANTI-CAVITATION TRIM

Model 106-AC allows very high pressure drops in one valve, while retaining the standard 106 valve features. See page 78.

Not available on PTC valves.

ORDERING INSTRUCTIONS

Refer to page 244 for the order form and ordering instructions.

MODEL 106-PT / 106-PTC / S106-PT / S106-PTC

Double Chamber Hydraulically Operated Valve

ANSI VALVE DATA (US UNITS)

SIZE	DWG	STANDARD	FLAT DIAPHRAGM SYSTEM					
INCHES	REF	ANSI	2"	2 1/2"	3"	4"	6"	8"
GLOBE DIMENSIONS			ALL FIGURES SHOW IN INCHES UNLESS OTHERWISE STATED					
Lay Length	A	FNPT	9.38	11.00	13.50	-	-	-
Centerline to Bottom	D	FNPT	2.75	3.38	3.68	-	-	-
Lay Length	A	150F	9.38	11.00	12.00	15.00	20.00	25.38
Centerline to Bottom	D	150F	3.00	3.50	3.75	4.60	5.60	7.88
Lay Length	A	300F	10.00	11.63	13.25	15.63	21.00	26.38
Centerline to Bottom	D	300F	3.25	3.75	4.13	5.09	6.34	7.88
ANGLE DIMENSIONS								
Center Inlet to Discharge	B	FNPT	4.69	5.50	6.63	-	-	-
Center Discharge to Inlet	F	FNPT	3.25	4.00	4.63	-	-	-
Center Inlet to Discharge	B	150F	4.75	5.50	6.06	7.50	10.00	12.75
Center Discharge to Inlet	F	150F	3.25	4.00	4.06	5.00	6.00	8.00
Center Inlet to Discharge	B	300F	5.00	5.88	6.43	7.88	10.50	13.25
Center Discharge to Inlet	F	300F	3.50	4.31	4.43	5.31	6.50	8.50
COMMON DIMENSIONS (GLOBE & ANGLE)								
Width	C		6.50	8.19	9.25	10.88	16.75	21.63
Height (To Stem Cap) Globe	E		6.13	8.93	9.75	10.88	13.88	17.75
Height (To Stem Cap) Angle	E		6.13	8.93	9.75	10.88	13.88	17.75
Body Port Tapping		FNPT	3/8	3/8	3/8	3/8	3/8	1/2
Stem Cap Plug		MNPT	3/8	3/8	3/8	3/8	3/8	3/8
Cover Port Tapping		FNPT	3/8	3/8	3/8	3/8	1/2	1/2
Valve Stroke			3/16	1	1 1/8	1 7/16	1 11/16	2 7/8
Displaced Bonnet Volume (Gallons)			0.02	0.1	0.1	0.2	0.6	1.7
Approximate Shipping Weight (Lbs)			40	65	100	175	400	650
FLOW CAPACITIES (USGPM) GLOBE & ANGLE								
C _v - Globe			55	80	110	200	460	800
C _v - Angle			63	90	135	230	535	950
Continuous (Globe)			210	300	460	800	1800	3100
Intermittent (Globe)			260	375	575	1000	2250	3875
Momentary (Globe)			470	670	1030	1800	4000	7000
MAXIMUM PRESSURE RATINGS (DUCTILE ONLY)								
psi ¹		FNPT	400	400	400	-	-	-
psi		150F	250	250	250	250	250	250
psi ¹		300F	400	400	400	400	400	400
Maximum Temperature								
Fahrenheit			180°	180°	180°	180°	180°	180°

¹Valves rated and stamped 400 psi as standard. Valves rated and stamped 600 psi on request.

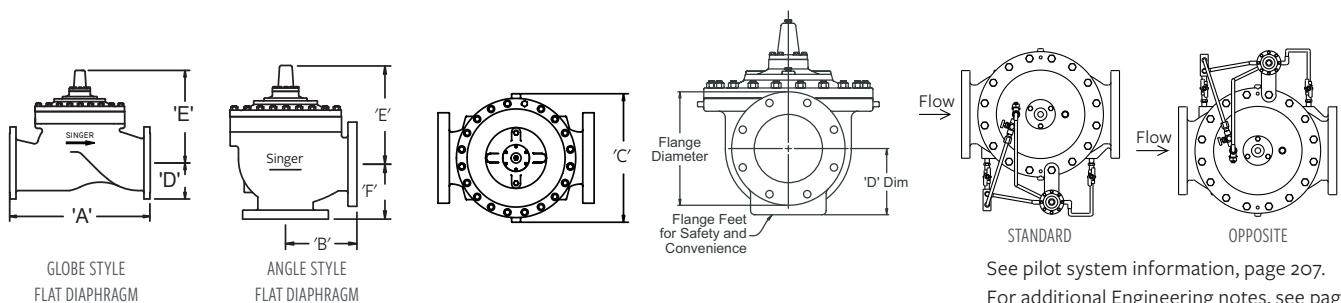

See pilot system information, page 207.

For additional Engineering notes, see page 242.

MODEL 106-PT / 106-PTC / S106-PT / S106-PTC

Double Chamber Hydraulically Operated Valve

ANSI VALVE DATA (US UNITS)

SIZE	DWG	STANDARD	ROLLING DIAPHRAGM SYSTEM							
INCHES	REF	ANSI	6"	8"	10"	12"	14"	16"	20"	24"
GLOBE DIMENSIONS			ALL FIGURES SHOWN IN INCHES UNLESS OTHERWISE STATED							
Lay Length	A	FNPT	-	-	-	-	-	-	-	-
Centerline to Bottom	D	FNPT	-	-	-	-	-	-	-	-
Lay Length	A	150F	20.00	25.38	29.75	34.00	31.00	41.38	52.00	61.50
Centerline to Bottom	D	150F	5.60	7.63	8.56	9.50	10.50	11.75	14.43	17.13
Lay Length	A	300F	21.00	26.38	31.12	35.50	32.50	43.50	53.62	63.25
Centerline to Bottom	D	300F	6.34	7.88	9.31	10.25	11.50	12.75	15.75	19.65
ANGLE DIMENSIONS										
Center Inlet to Discharge	B	FNPT	-	-	-	-	-	-	-	-
Center Discharge to Inlet	F	FNPT	-	-	-	-	-	-	-	-
Center Inlet to Discharge	B	150F	10.00	12.75	11.50	13.75	-	18.00	-	-
Center Discharge to Inlet	F	150F	6.00	8.00	12.50	12.50	-	15.69	-	-
Center Inlet to Discharge	B	300F	10.50	13.25	12.19	14.50	-	18.81	-	-
Center Discharge to Inlet	F	300F	6.50	8.50	13.19	13.25	-	16.50	-	-
COMMON DIMENSIONS (GLOBE & ANGLE)										
Width	C	-	12.75	17.25	22.13	26.00	26.00	32.00	35.00	49.68
Height (To Stem Cap) Globe	E	-	17.06	22.5	22.63	27.00	27.00	32.50	41.75	44.30
Height (To Stem Cap) Angle	E	-	17.06	22.5	19.34	24.00	-	29.50	-	-
Body Port Tapping		FNPT	3/8	1/2	3/4	3/4	3/4	3/4	3/4	3/4
Stem Cap Plug		MNPT	3/8	3/8	3/4	3/4	3/4	3/4	3/4	3/4
Cover Port Tapping		FNPT	1/2	1/2	3/4	3/4	3/4	3/4	3/4	3/4
Valve Stroke			1 1/16	2 7/8	3 1/4	3 3/4	3 3/4	4 3/4	5 9/16	6
Displaced Bonnet Volume (Gallons)			0.50	1.00	1.5	2.3	2.3	6.8	9.0	14.8
Approximate Shipping Weight (Lbs)			375	700	900	1300	1400	2300	3670	5000
FLOW CAPACITIES (USGPM) GLOBE & ANGLE										
C _v - Globe			460	800	1300	2100	2575	3300	5100	7600
C _v - Angle			535	950	1400	2450	-	4000	-	-
Continuous (Globe)			1800	3100	4900	7000	8500	11000	17500	25000
Intermittent (Globe)			2250	3875	6100	8800	11500	14250	21700	31200
Momentary (Globe)			4000	7000	11000	16000	19000	25000	39000	56200
MAXIMUM PRESSURE RATINGS (DUCTILE ONLY)										
psi ¹		FNPT	-	-	-	-	-	-	-	-
psi		150F	250	250	250	250	250	250	250	250
psi ¹		300F	400	400	400	400	400	400	400	400
MAXIMUM TEMPERATURE										
Fahrenheit			180°	180°	180°	180°	180°	180°	180°	180°

¹Valves rated and stamped 400 psi as standard. Valves rated and stamped 600 psi on request.

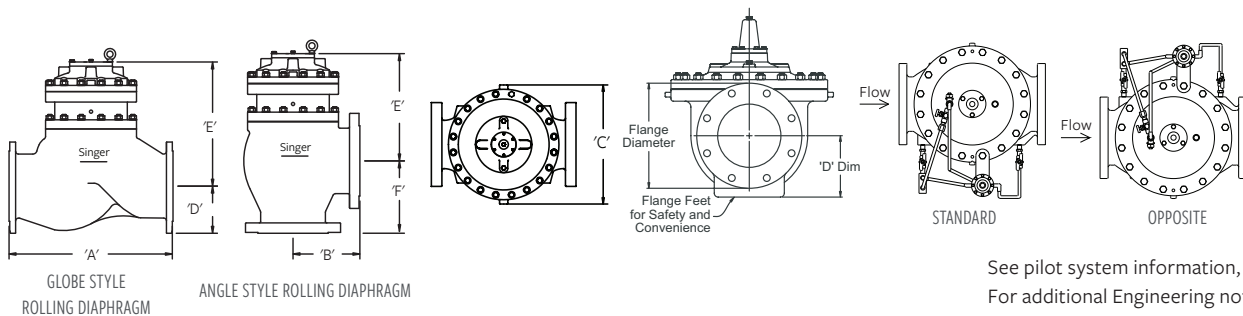

See pilot system information, page 207.
For additional Engineering notes, see page 242.

MODEL 106-PT / 106-PTC / S106-PT / S106-PTC

Double Chamber Hydraulically Operated Valve

ANSI VALVE DATA (METRIC UNITS)

SIZE	DWG	STANDARD	FLAT DIAPHRAGM SYSTEM					
			MM	REF	ANSI	50 MM	65 MM	80 MM
GLOBE DIMENSIONS			ALL FIGURES SHOW IN MM UNLESS OTHERWISE STATED					
Lay Length	A	FNPT	238	279	343	-	-	-
Centerline to Bottom	D	FNPT	70	86	93	-	-	-
Lay Length	A	150F	238	279	305	381	508	645
Centerline to Bottom	D	150F	76	89	95	117	142	200
Lay Length	A	300F	254	295	337	397	533	670
Centerline to Bottom	D	300F	83	95	105	129	161	200
ANGLE DIMENSIONS								
Center Inlet to Discharge	B	FNPT	119	140	168	-	-	-
Center Discharge to Inlet	F	FNPT	83	102	118	-	-	-
Center Inlet to Discharge	B	150F	121	140	154	191	254	324
Center Discharge to Inlet	F	150F	83	102	103	127	152	203
Center Inlet to Discharge	B	300F	127	149	163	200	267	337
Center Discharge to Inlet	F	300F	89	109	113	135	165	216
COMMON DIMENSIONS (GLOBE & ANGLE)								
Width	C		165	208	235	276	425	549
Height (To Stem Cap) Globe	E		156	227	248	276	353	451
Height (To Stem Cap) Angle	E		156	227	248	276	353	451
Body Port Tapping	FNPT	Inches	3/8	3/8	3/8	3/8	3/8	1/2
Stem Cap Plug	MNPT	Inches	3/8	3/8	3/8	3/8	3/8	3/8
Cover Port Tapping	FNPT	Inches	3/8	3/8	3/8	3/8	1/2	1/2
Valve Stroke		mm	14	25	29	37	43	73
Displaced Bonnet Volume (Litres)			0.1	0.3	0.3	0.8	2.1	6.3
Approximate Shipping Weight (Kilograms)			18	29	45	79	181	295
FLOW CAPACITIES (L/S) GLOBE & ANGLE								
K _v - Globe (m ³ /h @ 1 bar)			48	69	95	173	398	692
K _v - Angle (m ³ /h @ 1 bar)			54	78	117	199	463	822
Continuous (Globe)			13	19	29	50	114	196
Intermittent (Globe)			16	24	36	63	142	244
Momentary (Globe)			30	42	65	114	252	442
MAXIMUM PRESSURE RATINGS								
Bar ¹		FNPT	27.6	27.6	27.6	-	-	-
Bar		150F	17	17	17	17	17	17
Bar		300F	27.6	27.6	27.6	27.6	27.6	27.6
MAXIMUM TEMPERATURE								
Celcius			82°	82°	82°	82°	82°	82°

¹Valves rated and stamped 27.6 bar as standard. Valves rated and stamped 41 bar on request.

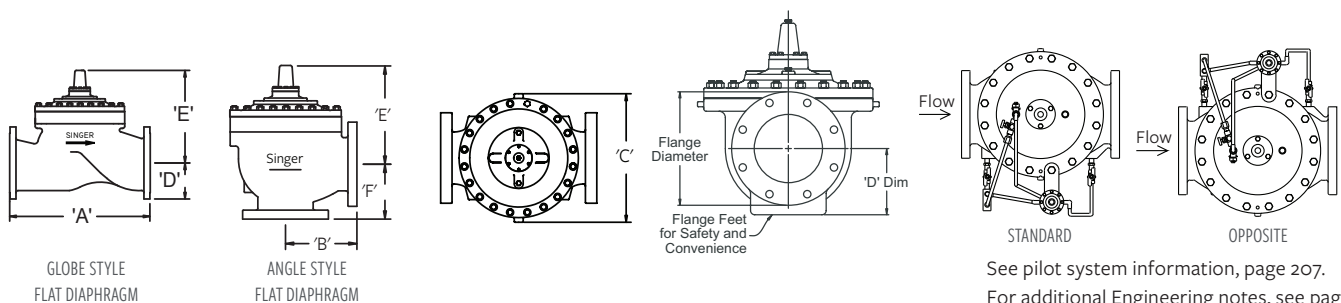

See pilot system information, page 207.

For additional Engineering notes, see page 242.

MODEL 106-PT / 106-PTC / S106-PT / S106-PTC

Double Chamber Hydraulically Operated Valve

ANSI VALVE DATA (METRIC UNITS)

SIZE	DWG REF	STANDARD ANSI	ROLLING DIAPHRAGM SYSTEM							
			150 MM	200 MM	250 MM	300 MM	350 MM	400 MM	500 MM	600 MM
GLOBE DIMENSIONS			ALL FIGURES SHOWN IN MM UNLESS OTHERWISE STATED							
Lay Length	A	FNPT	-	-	-	-	-	-	-	-
Centerline to Bottom	D	FNPT	-	-	-	-	-	-	-	-
Lay Length	A	150F	508	645	756	864	787	1051	1321	1562
Centerline to Bottom	D	150F	142	200	217	241	267	298	367	435
Lay Length	A	300F	533	670	790	902	826	1105	1362	1607
Centerline to Bottom	D	300F	161	200	243	260	292	324	400	499
ANGLE DIMENSIONS										
Center Inlet to Discharge	B	FNPT	-	-	-	-	-	-	-	-
Center Discharge to Inlet	F	FNPT	-	-	-	-	-	-	-	-
Center Inlet to Discharge	B	150F	254	324	292	349	-	457	-	-
Center Discharge to Inlet	F	150F	152	203	318	318	-	399	-	-
Center Inlet to Discharge	B	300F	267	337	310	368	-	478	-	-
Center Discharge to Inlet	F	300F	165	216	335	337	-	419	-	-
COMMON DIMENSIONS (GLOBE & ANGLE)										
Width	C	-	324	438	562	660	660	813	889	1262
Height (To Stem Cap) Globe	E	-	435	575	575	686	686	826	1060	1125
Height (To Stem Cap) Angle	E	-	435	575	491	610	-	749	-	-
Body Port Tapping	FNPT	Inches	3/8	1/2	3/4	3/4	3/4	3/4	3/4	3/4
Stem Cap Plug	MNPT	Inches	3/8	3/8	3/4	3/4	3/4	3/4	3/4	3/4
Cover Port Tapping	FNPT	Inches	1/2	1/2	3/4	3/4	3/4	3/4	3/4	3/4
Valve Stroke		mm	43	73	83	95	95	120	141	150
Displaced Bonnet Volume (Litres)			2	4	6	9	9	26	34	56
Approximate Shipping Weight (Kilograms)			170	318	480	590	635	1043	1665	2268
FLOW CAPACITIES (L/S) GLOBE & ANGLE										
K _v - Globe (m ³ /h @ 1 bar)			398	692	1125	1817	2227	2855	4412	6574
K _v - Angle (m ³ /h @ 1 bar)			463	822	1211	2119	-	3460	-	-
Continuous (Globe)			114	196	309	442	536	694	1104	1577
Intermittent (Globe)			142	244	385	555	726	899	1370	1968
Momentary (Globe)			252	442	694	1009	1199	1577	2460	3546
MAXIMUM PRESSURE RATINGS										
Bar ¹		FNPT	-	-	-	-	-	-	-	-
Bar		150F	17	17	17	17	17	17	17	17
Bar ¹		300F	27.6	27.6	27.6	27.6	27.6	27.6	27.6	27.6
MAXIMUM TEMPERATURE										
Celcius			82°	82°	82°	82°	82°	82°	82°	82°

¹Valves rated and stamped 27.6 Bar as standard. Valves rated and stamped 41 Bar on request.

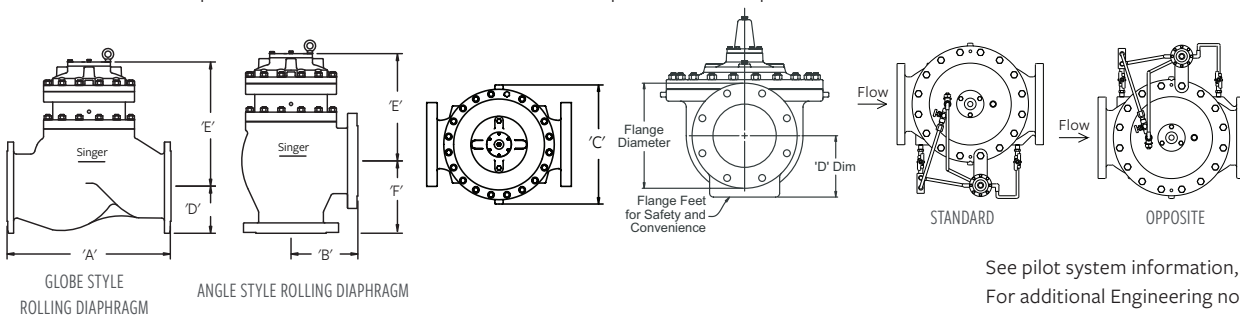

See pilot system information, page 207.
For additional Engineering notes, see page 242.

MODEL 106-PT / 106-PTC / S106-PT / S106-PTC

Double Chamber Hydraulically Operated Valve

ISO VALVE DATA (METRIC UNITS)

SIZE	DWG	STANDARD	FLAT DIAPHRAGM SYSTEM					
			50 MM	65 MM	80 MM	100 MM	150 MM	200 MM
MM	REF	ISO						
GLOBE DIMENSIONS			ALL FIGURES SHOWN IN MM UNLESS OTHERWISE STATED					
Lay Length	A	BSPT	238	279	343	-	-	-
Centerline to Bottom	D	BSPT	70	86	93	-	-	-
Lay Length	A	PN10 / PN16	238	279	318	381	508	645
Centerline to Bottom	D	PN10 / PN16	76	89	100	117	142	200
Lay Length	A	PN25 / PN40	238	279	318	397	533	670
Centerline to Bottom	D	PN25 / PN40	76	89	100	129	161	200
ANGLE DIMENSIONS								
Center Inlet to Discharge	B	BSPT	119	140	168	-	-	-
Center Discharge to Inlet	F	BSPT	83	102	118	-	-	-
Center Inlet to Discharge	B	PN10 / PN16	121	140	163	191	254	324
Center Discharge to Inlet	F	PN10 / PN16	83	102	113	127	152	203
Center Inlet to Discharge	B	PN25 / PN40	121	140	163	200	267	337
Center Discharge to Inlet	F	PN25 / PN40	83	102	113	135	165	216
COMMON DIMENSIONS (GLOBE & ANGLE)								
Width	C		165	208	235	276	425	549
Height (To Stem Cap) Globe	E		156	227	248	276	353	451
Height (To Stem Cap) Angle	E		156	227	248	276	353	451
Body Port Tapping	FNPT	Inches	3/8	3/8	3/8	3/8	3/8	1/2
Stem Cap Plug	MNPT	Inches	3/8	3/8	3/8	3/8	3/8	3/8
Cover Port Tapping	FNPT	Inches	3/8	3/8	3/8	3/8	1/2	1/2
Valve Stroke		mm	14	25	29	37	43	73
Displaced Bonnet Volume (Litres)			0.1	0.3	0.3	0.8	2.1	6.3
Approximate Shipping Weight (Kilograms)			18	29	45	79	181	295
FLOW CAPACITIES (L/S) GLOBE & ANGLE								
K_v - Globe (m ³ /h @ 1 bar)			48	69	95	173	398	692
K_v - Angle (m ³ /h @ 1 bar)			54	78	117	199	463	822
Continuous (Globe)			13	19	29	50	114	196
Intermittent (Globe)			16	24	36	63	142	244
Momentary (Globe)			30	42	65	114	252	442
MAXIMUM PRESSURE RATINGS								
Bar		BSPT	27.6	27.6	27.6	-	-	-
Bar		PN16	16	16	16	16	16	16
Bar		PN25	25	25	25	25	25	25
MAXIMUM TEMPERATURE								
Celcius			82°	82°	82°	82°	82°	82°

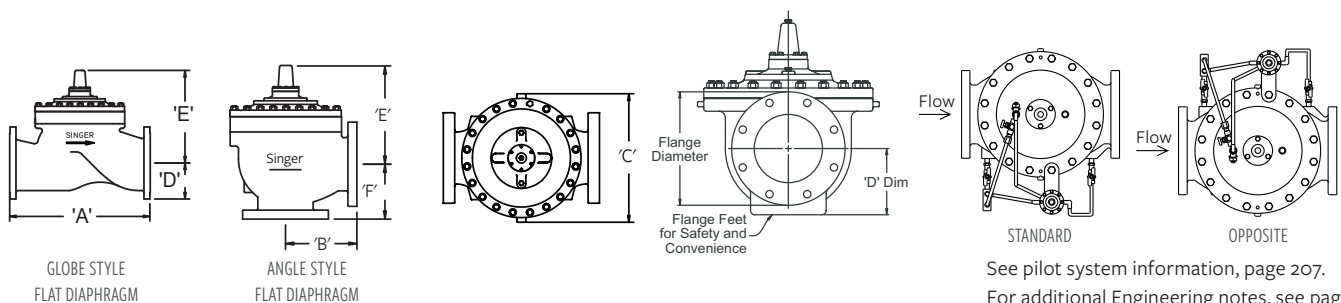

See pilot system information, page 207.
For additional Engineering notes, see page 242.

MODEL 106-PT / 106-PTC / S106-PT / S106-PTC

Double Chamber Hydraulically Operated Valve

ISO VALVE DATA (METRIC UNITS)

SIZE	DWG	STANDARD	ROLLING DIAPHRAGM SYSTEM							
			150 MM	200 MM	250 MM	300 MM	350 MM	400 MM	500 MM	600 MM
MM	REF	ISO	ALL FIGURES SHOWN IN MM UNLESS OTHERWISE STATED.							
GLOBE DIMENSIONS										
Lay Length	A	BSPT	-	-	-	-	-	-	-	-
Centerline to Bottom	D	BSPT	-	-	-	-	-	-	-	-
Lay Length	A	PN10 / PN16	508	645	756	864	787	1051	1321	1562
Centerline to Bottom	D	PN10 / PN16	142	200	217	241	267	298	367	435
Lay Length	A	PN25 / PN40	533	670	790	864	826	1105	1362	1607
Centerline to Bottom	D	PN25 / PN40	161	200	243	241	292	324	400	499
ANGLE DIMENSIONS										
Center Inlet to Discharge	B	BSPT	-	-	-	-	-	-	-	-
Center Discharge to Inlet	F	BSPT	-	-	-	-	-	-	-	-
Center Inlet to Discharge	B	PN10 / PN16	254	324	292	349	-	457	-	-
Center Discharge to Inlet	F	PN10 / PN16	152	203	318	318	-	399	-	-
Center Inlet to Discharge	B	PN25 / PN40	267	337	310	349	-	478	-	-
Center Discharge to Inlet	F	PN25 / PN40	165	216	335	318	-	419	-	-
COMMON DIMENSIONS (GLOBE & ANGLE)										
Width	C		324	438	562	660	660	813	889	1262
Height (To Stem Cap) Globe	E		435	575	575	686	686	826	1060	1125
Height (To Stem Cap) Angle	E		435	575	491	610	-	749	-	-
Body Port Tapping	FNPT	Inches	3/8	1/2	3/4	3/4	3/4	3/4	3/4	3/4
Stem Cap Plug	MNPT	Inches	3/8	3/8	3/4	3/4	3/4	3/4	3/4	3/4
Cover Port Tapping	FNPT	Inches	1/2	1/2	3/4	3/4	3/4	3/4	3/4	3/4
Valve Stroke		mm	43	73	83	95	95	120	141	150
Displaced Bonnet Volume (Litres)			2	4	6	9	9	26	34	56
Approximate Shipping Weight (Kilograms)			170	318	480	590	635	1043	1665	2268
FLOW CAPACITIES (L/S) GLOBE & ANGLE										
K _v - Globe (m ³ /h @ 1 bar)			398	692	1125	1817	2227	2855	4412	6574
K _v - Angle (m ³ /h @ 1 bar)			463	822	1211	2119	-	3460	-	-
Continuous (Globe)			114	196	309	442	536	694	1104	1577
Intermittent (Globe)			142	244	385	555	726	899	1370	1968
Momentary (Globe)			252	442	694	1009	1199	1577	2460	3546
MAXIMUM PRESSURE RATINGS										
Bar		BSPT	-	-	-	-	-	-	-	-
Bar		PN16	16	16	16	16	16	16	16	16
Bar		PN25	25	25	25	25	25	25	25	25
MAXIMUM TEMPERATURE										
Celcius			82°	82°	82°	82°	82°	82°	82°	82°

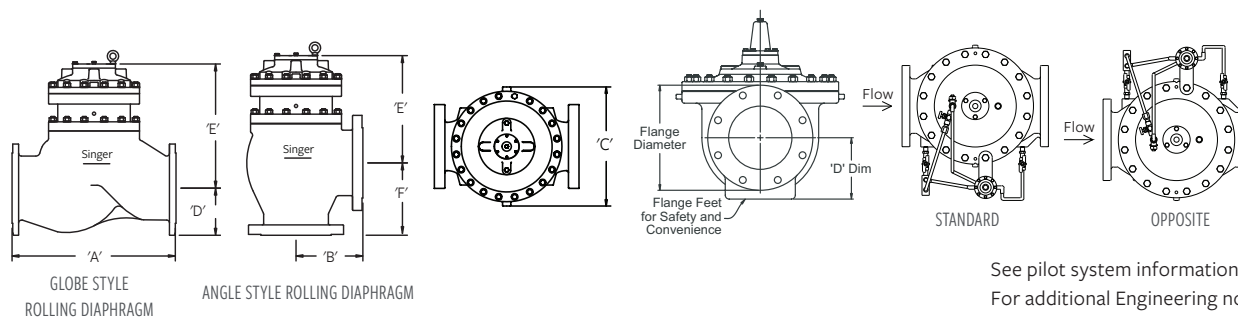

See pilot system information, page 207.
For additional Engineering notes, see page 242.

MODEL 206-PT / 206-PTC / S206-PT / S206-PTC

Double Chamber Hydraulically Operated Valve

KEY FEATURES

- Positive control, even with low operating pressure
- Precise positioning
- Internal drop check included on the PTC model
- Available in globe and angle style

PRODUCT OVERVIEW

The 206-PT and 206-PTC series control valves are hydraulically operated by introducing or releasing water from the control chambers. PT and PTC valves have two operating chambers which are divided from each other by the diaphragm, and are separated from the flowing media by an adaptor plate.

206-PTC is an enhancement of the 206-PT and includes an internal drop check feature. This mechanical check provides non-slam closure on reverse flow, independently of the stem position or the pilot operation.

PT and PTC valves are usually combined with our specific purpose pilots and accessories to provide control for a wide range of functions: typically pump control and solenoid control applications.

Refer to Main Valve Options on page 62 and Pilots & Accessories on page 207 to further customize the valve to suit specific applications.



ALTERNATIVE MODELS



A206-PT ANGLE

PRODUCT LINE DRAWING

ID	PART NAME
1	Optional Model X129 Limit Switch Assembly
2	Double Chambers Separated From The Flowing Media
3	ASTM A536 Ductile Iron Construction
4	Optional Internal Check Feature (PT)
5	EPDM Resilient Disc
6	AISI 316 Stainless Steel Seat
7	AISI 316 Stainless Steel Stem
8	NSF 61 Fusion Bonded Epoxy Coating

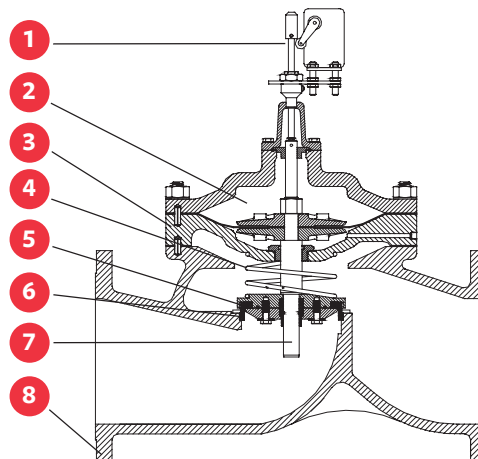

SELECTION

The 206-PT and 206-PTC valves operate by introducing or exhausting water from the upper and lower chambers at controlled rates. Since the operating chambers are separated from the flowing media, a positive and precise differential pressure can be established across the diaphragm. Valves are sized to provide an appropriate pressure drop for each application. Valves usually exhaust to atmosphere. Sizing is ultimately determined by the specific application. Refer to the capacity charts for general guidelines.

MODEL 206-PT / 206-PTC / S206-PT / S206-PTC

Double Chamber Hydraulically Operated Valve

VALVE SIZES & MATERIALS

VALVE MATERIALS

	Standard	Optional
Available Sizes	Flanged	-
Globe	3" to 36" (80 mm - 900 mm)	-
Angle	4" to 8" (100 mm - 200 mm)	-

VALVE COMPONENTS

1. Valve Body, Cover	65-45-12 Ductile Iron	316 Stainless Steel (limited sizes)
2. Seat Ring	316 Stainless Steel	-
3. Disc Retainer	B16 Brass / B62 Bronze / A536 Ductile Iron	316 Stainless Steel
4. Stem	316 Stainless Steel	-
5. Stem Nut	B16 Brass	316 Stainless Steel
6. Spring	316 Stainless Steel	-
7. Guide Bushings	B16 Brass or SAE 660 Bronze	316 Stainless Steel
8. Diaphragm	EPDM	Buna-N / Viton (limited sizes)
9. Resilient Disc	EPDM	Buna-N / Viton (limited sizes)
10. Coating	NSF61 Approved Fusion Bonded Epoxy - Thickness 10-14 mils (250-350 microns)	Consult factory
11. Fasteners	18-8 Stainless Steel	316 Stainless Steel

Double-chambered automatic control valves are typically used for pump control. Other uses would include but not be limited to low-pressure differential applications. 206-PT and 206-PTC valves are particularly well suited for applications that require valves to open fully regardless of flow or pressure drop or any application where more relatively constant, controlled speed is required.

AVAILABLE OPTIONS

Further customize the valve by adding any of the available options below.

MAIN VALVE OPTIONS, REFER TO PAGE 62

Position Indicators (Available for install at Singer® manufacturing or as a field modification)

- Model X107 stem mounted position indicators
- Model X129 limit switch assembly with Single Pole Double Throw limit switch (Double Pole Double Throw optional)
- Model X156 analog position transmitters (4 - 20 mA)

Oxy-Nitride Stem

Reclaimed Water

PILOTS & ACCESSORIES, REFER TO PAGE 207 MATERIALS OF CONSTRUCTION

Individual components can be upgraded from ductile iron, bronze and brass to stainless steel, for most sizes. Consult with us.

ORDERING INSTRUCTIONS

Refer to page 244 for the order form and ordering instructions.

Grooved Ends

MODEL 206-PT / 206-PTC / S206-PT / S206-PTC

Double Chamber Hydraulically Operated Valve

VALVE DATA (US UNITS)

SIZE	DWG	STANDARD	FLAT DIAPHRAGM SYSTEM						
			INCHES	REF	ANSI	3"	4"	6"	8"
GLOBE DIMENSIONS			ALL FIGURES SHOWN IN INCHES UNLESS OTHERWISE STATED						
Lay Length	A	FNPT	-	-	-	-	-	-	
Centerline to Bottom	D	FNPT	-	-	-	-	-	-	
Lay Length	A	150F	12.00	15.00	20.13	25.00	24.50		
Centerline to Bottom	D	150F	4.00	4.60	5.62	6.75	8.56		
Lay Length	A	300F	-	15.63	21.00	26.00	25.88		
Centerline to Bottom	D	300F	-	5.00	6.34	7.50	9.31		
ANGLE DIMENSIONS									
Center Inlet to Discharge	B	FNPT	-	-	-	-	-	-	
Center Discharge to Inlet	F	FNPT	-	-	-	-	-	-	
Center Inlet to Discharge	B	150F	-	7.56	10.19	12.50	-	-	
Center Discharge to Inlet	F	150F	-	5.94	6.19	9.00	-	-	
Center Inlet to Discharge	B	300F	-	7.88	10.63	13.00	-	-	
Center Discharge to Inlet	F	300F	-	6.25	6.81	9.50	-	-	
COMMON DIMENSIONS (GLOBE & ANGLE)									
Width	C		8.19	10.00	12.50	16.00	20.00		
Height (To Stem Cap) Globe	E		8.93	11.28	12.25	16.25	21.38		
Height (To Stem Cap) Angle	E		-	9.50	10.50	13.43	-		
Body Port Tapping		FNPT	$\frac{3}{8}$	$\frac{3}{8}$	$\frac{3}{8}$	$\frac{1}{2}$	$\frac{1}{2}$		
Stem Cap Plug		MNPT	$\frac{3}{8}$	$\frac{3}{8}$	$\frac{3}{8}$	$\frac{3}{8}$	$\frac{3}{8}$		
Cover Port Tapping		FNPT	$\frac{3}{8}$	$\frac{3}{8}$	$\frac{3}{8}$	$\frac{1}{2}$	$\frac{1}{2}$		
Valve Stroke			$1\frac{15}{16}$	$1\frac{1}{8}$	$1\frac{7}{16}$	$1\frac{11}{16}$	$2\frac{7}{8}$		
Displaced Bonnet Volume (Gallons)			0.02	0.1	0.2	0.6	1.7		
Approximate Shipping Weight (Lbs)			75	100	250	500	650		
Flow Capacities (USGPM) Globe & Angle									
C_v - Globe			60	150	250	505	985		
C_v - Angle			-	150	250	560	-		
Continuous (Globe)			300	580	1025	2300	4100		
Intermittent (Globe)			373	690	1190	2700	4670		
Momentary (Globe)			564	1236	2160	4800	8400		
MAXIMUM PRESSURE RATINGS (DUCTILE ONLY)									
psi		FNPT	-	-	-	-	-		
psi		150F	250	250	250	250	250		
psi ¹		300F	400	400	400	400	400		
MAXIMUM TEMPERATURE									
Fahrenheit			180°	180°	180°	180°	180°		

¹Valves rated and stamped 400 psi as standard. Valves rated and stamped 600 psi on request.

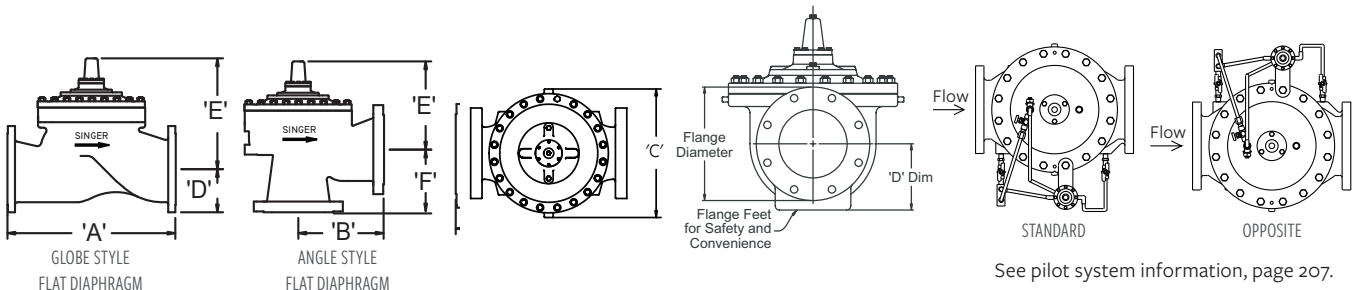

See pilot system information, page 207.
For additional Engineering notes, see page 242.

MODEL 206-PT / 206-PTC / S206-PT / S206-PTC

Double Chamber Hydraulically Operated Valve

VALVE DATA (US UNITS)

SIZE	DWG	STANDARD	ROLLING DIAPHRAGM SYSTEM								
			INCHES	REF	ANSI	12"	16"	18"	20"	24" X 16"	24" X 20"
GLOBE DIMENSIONS			ALL FIGURES SHOWN IN INCHES UNLESS OTHERWISE STATED.								
Lay Length	A	FNPT	-	-	-	-	-	-	-	-	-
Centerline to Bottom	D	FNPT	-	-	-	-	-	-	-	-	-
Lay Length	A	150F	27.50	36.00	42.00	45.00	50.50	61.50	69.93	69.93	
Centerline to Bottom	D	150F	9.50	11.75	12.50	13.93	16.50	17.13	20.69	23.75	
Lay Length	A	300F	29.00	37.63	43.63	46.63	52.25	63.25	-	-	
Centerline to Bottom	D	300F	10.50	12.75	14.00	15.25	18.00	19.65	-	-	
ANGLE DIMENSIONS											
Center Inlet to Discharge	B	FNPT	-	-	-	-	-	-	-	-	
Center Discharge to Inlet	F	FNPT	-	-	-	-	-	-	-	-	
Center Inlet to Discharge	B	150F	-	-	-	-	-	-	-	-	
Center Discharge to Inlet	F	150F	-	-	-	-	-	-	-	-	
Center Inlet to Discharge	B	300F	-	-	-	-	-	-	-	-	
Center Discharge to Inlet	F	300F	-	-	-	-	-	-	-	-	
COMMON DIMENSIONS (GLOBE & ANGLE)											
Width	C		22.13	26.00	31.31	31.50	36.00	36.00	49.75	49.75	
Height (To Stem Cap) Globe	E		22.63	27.00	32.38	32.38	32.38	41.75	45.75	45.75	
Height (To Stem Cap) Angle	E		-	-	-	-	-	-	-	-	
Body Port Tapping		FNPT	3/4	3/4	3/4	3/4	3/4	3/4	3/4	3/4	
Stem Cap Plug		MNPT	3/4	3/4	3/4	3/4	3/4	3/4	3/4	3/4	
Cover Port Tapping		FNPT	3/4	3/4	3/4	3/4	3/4	3/4	3/4	3/4	
Valve Stroke			3 1/4	3 3/4	4 3/4	4 3/4	4 3/4	5 9/16	6	6	
Displaced Bonnet Volume (Gallons)			1.5	2.3	6.8	6.8	14.8	9.0	14.8	14.8	
Approximate Shipping Weight (Lbs)			900	1400	2400	2600	2800	3240	6200	7000	
FLOW CAPACITIES (USGPM) GLOBE & ANGLE											
C _v - Globe			1550	2200	3300	3400	3500	5100	7800	8000	
C _v - Angle			-	-	-	-	-	-	-	-	
Continuous (Globe)			6400	9230	16500	16500	16500	21700	33650	33800	
Intermittent (Globe)			7320	10470	20915	20915	20915	26000	37490	37640	
Momentary (Globe)			13200	19200	30000	30050	30100	39000	67490	67640	
MAXIMUM PRESSURE RATINGS (DUCTILE ONLY)											
psi		FNPT	-	-	-	-	-	-	-	-	
psi		150F	250	250	250	250	250	250	250	250	
psi ¹		300F	400	400	400	400	400	400	400	400	
MAXIMUM TEMPERATURE											
Fahrenheit			180°	180°	180°	180°	180°	180°	180°	180°	

¹Valves rated and stamped 400 psi as standard. Valves rated and stamped 600 psi on request.

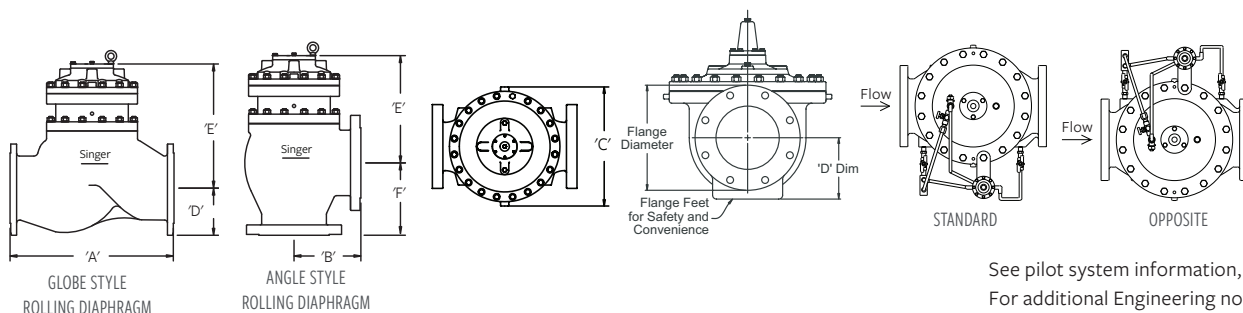

See pilot system information, page 207.

For additional Engineering notes, see page 242.

MODEL 206-PT / 206-PTC / S206-PT / S206-PTC

Double Chamber Hydraulically Operated Valve

ANSI VALVE DATA (METRIC UNITS)

SIZE	DWG	STANDARD	FLAT DIAPHRAGM SYSTEM				
			80 MM	100 MM	150 MM	200 MM	250 MM
MM	REF	ANSI	ALL FIGURES SHOWN IN MM UNLESS OTHERWISE STATED				
GLOBE DIMENSIONS							
Lay Length	A	FNPT	-	-	-	-	-
Centerline to Bottom	D	FNPT	-	-	-	-	-
Lay Length	A	150F	305	381	511	635	622
Centerline to Bottom	D	150F	102	117	143	171	217
Lay Length	A	300F	-	397	533	660	657
Centerline to Bottom	D	300F	-	127	161	191	236
ANGLE DIMENSIONS							
Center Inlet to Discharge	B	FNPT	-	-	-	-	-
Center Discharge to Inlet	F	FNPT	-	-	-	-	-
Center Inlet to Discharge	B	150F	-	192	259	318	-
Center Discharge to Inlet	F	150F	-	151	157	229	-
Center Inlet to Discharge	B	300F	-	200	270	330	-
Center Discharge to Inlet	F	300F	-	159	173	241	-
COMMON DIMENSIONS (GLOBE & ANGLE)							
Width	C		208	254	318	406	508
Height (To Stem Cap) Globe	E		227	287	311	413	543
Height (To Stem Cap) Angle	E		-	241	267	341	-
Body Port Tapping	FNPT	Inches	3/8	3/8	3/8	3/8	1/2
Stem Cap Plug	MNPT	Inches	3/8	3/8	3/8	3/8	3/8
Cover Port Tapping	FNPT	Inches	3/8	3/8	3/8	1/2	1/2
Valve Stroke		mm	14	29	37	43	73
Displaced Bonnet Volume (Litres)			0.1	0.3	0.8	2.1	6.3
Approximate Shipping Weight (Kilograms)			34	45	113	227	295
FLOW CAPACITIES (L/S) GLOBE & ANGLE							
K_v - Globe (m^3/h @ 1 bar)			52	130	216	437	852
K_v - Angle (m^3/h @ 1 bar)			-	130	216	484	-
Continuous (Globe)			19	37	65	145	259
Intermittent (Globe)			24	44	75	170	295
Momentary (Globe)			36	78	136	303	530
MAXIMUM PRESSURE RATINGS (DUCTILE ONLY)							
Bar		FNPT	-	-	-	-	-
Bar		150F	17	17	17	17	17
Bar ¹		300F	27.6	27.6	27.6	27.6	27.6
MAXIMUM TEMPERATURE							
Celcius			82°	82°	82°	82°	82°

¹Valves rated and stamped 27.6 bar as standard. Valves rated and stamped 41 bar on request.

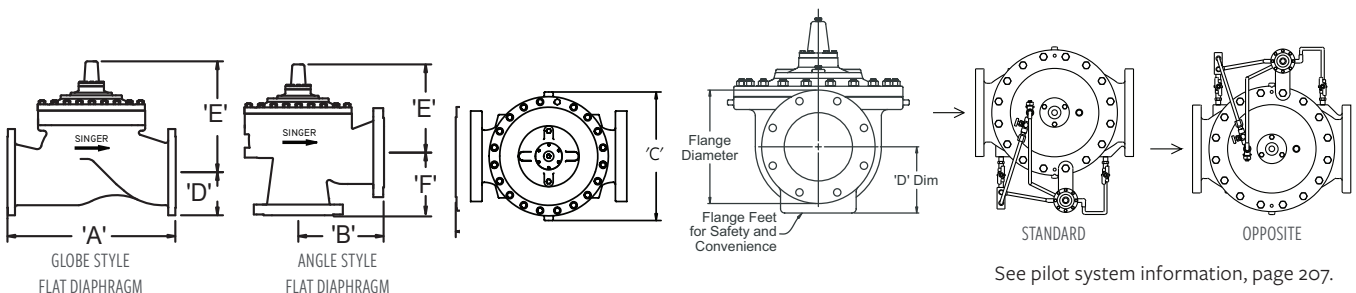

See pilot system information, page 207.
For additional Engineering notes, see page 242.

MODEL 206-PT / 206-PTC / S206-PT / S206-PTC

Double Chamber Hydraulically Operated Valve

ANSI VALVE DATA (METRIC UNITS)

SIZE	DWG	STANDARD	ROLLING DIAPHRAGM SYSTEM						
MM	REF	ANSI	300 MM	400 MM	450 MM	500 MM	600 X 400 MM	600 X 500 MM	900 MM
GLOBE DIMENSIONS			ALL FIGURES SHOWN IN MM UNLESS OTHERWISE STATED.						
Lay Length	A	FNPT	-	-	-	-	-	-	-
Centerline to Bottom	D	FNPT	-	-	-	-	-	-	-
Lay Length	A	150F	699	914	1067	1143	1283	1562	1776
Centerline to Bottom	D	150F	241	298	318	354	419	435	588
Lay Length	A	300F	737	956	1108	1184	1327	1607	-
Centerline to Bottom	D	300F	267	324	356	387	457	499	-
ANGLE DIMENSIONS									
Center Inlet to Discharge	B	FNPT	-	-	-	-	-	-	-
Center Discharge to Inlet	F	FNPT	-	-	-	-	-	-	-
Center Inlet to Discharge	B	150F	-	-	-	-	-	-	-
Center Discharge to Inlet	F	150F	-	-	-	-	-	-	-
Center Inlet to Discharge	B	300F	-	-	-	-	-	-	-
Center Discharge to Inlet	F	300F	-	-	-	-	-	-	-
COMMON DIMENSIONS GLOBE									
Width	C		562	660	795	800	914	914	1262
Height (To Stem Cap) Globe	E		575	686	822	822	822	1060	1162
Height (To Stem Cap) Angle	E		-	-	-	-	-	-	-
Body Port Tapping	FNPT	Inches	3/4	3/4	3/4	3/4	3/4	3/4	3/4
Stem Cap Plug	MNPT	Inches	3/4	3/4	3/4	3/4	3/4	3/4	3/4
Cover Port Tapping	FNPT	Inches	3/4	3/4	3/4	3/4	3/4	3/4	3/4
Valve Stroke		mm	83	95	120	120	120	141	150
Displaced Bonnet Volume (Liters)			6	9	26	26	26	34	56
Approximate Shipping Weight (Kilograms)			408	635	1089	1179	1270	1470	3175
FLOW CAPACITIES (L/S) GLOBE									
K_v - Globe (m^3/h @ 1 bar)			1341	1903	2855	2941	3028	4412	6920
K_v - Angle (m^3/h @ 1 bar)			-	-	-	-	-	-	-
Continuous (Globe)			404	582	1041	1041	1041	1370	2132
Intermittent (Globe)			465	661	1320	1320	1320	1640	2375
Momentary (Globe)			833	1211	1893	1896	1899	2460	4267
MAXIMUM PRESSURE RATINGS (DUCTILE ONLY)									
Bar	FNPT		-	-	-	-	-	-	-
Bar	150F		17	17	17	17	17	17	17
Bar ¹	300F		27.6	27.6	27.6	27.6	27.6	27.6	27.6
MAXIMUM TEMPERATURE									
Celsius			82°	82°	82°	82°	82°	82°	82°

¹Valves rated and stamped 27.6 bar as standard. Valves rated and stamped 41 bar on request.

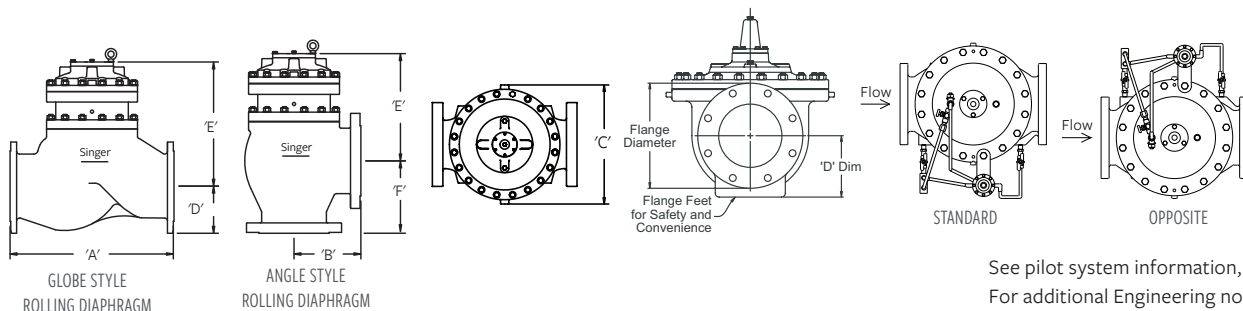

See pilot system information, page 207.
For additional Engineering notes, see page 242.

MODEL 206-PT / 206-PTC / S206-PT / S206-PTC

Double Chamber Hydraulically Operated Valve

ISO VALVE DATA (METRIC UNITS)

SIZE	DWG	STANDARD	FLAT DIAPHRAGM SYSTEM				
			80 MM	100 MM	150 MM	200 MM	250 MM
MM	REF	ISO	ALL FIGURES SHOWN IN MM UNLESS OTHERWISE STATED				
GLOBE DIMENSIONS							
Lay Length	A	BSPT	-	-	-	-	-
Centerline to Bottom	D	BSPT	-	-	-	-	-
Lay Length	A	PN10/PN16	305	381	511	635	622
Centerline to Bottom	D	PN10/PN16	102	117	143	171	217
Lay Length	A	PN25/PN40	-	397	533	660	657
Centerline to Bottom	D	PN25/PN40	-	127	161	191	236
ANGLE DIMENSIONS							
Center Inlet to Discharge	B	BSPT	-	-	-	-	-
Center Discharge to Inlet	F	BSPT	-	-	-	-	-
Center Inlet to Discharge	B	PN10/PN16	-	192	259	318	-
Center Discharge to Inlet	F	PN10/PN16	-	151	157	229	-
Center Inlet to Discharge	B	PN25/PN40	-	200	270	330	-
Center Discharge to Inlet	F	PN25/PN40	-	159	173	241	-
COMMON DIMENSIONS (GLOBE & ANGLE)							
Width	C		208	254	318	406	508
Height (To Stem Cap) Globe	E		227	287	311	413	543
Height (To Stem Cap) Angle	E		-	241	267	341	-
Body Port Tapping	FNPT	Inches	3/8	3/8	3/8	3/8	1/2
Stem Cap Plug	MNPT	Inches	3/8	3/8	3/8	3/8	3/8
Cover Port Tapping	FNPT	Inches	3/8	3/8	3/8	1/2	1/2
Valve Stroke		mm	14	29	37	43	73
Displaced Bonnet Volume (Litre)			0.1	0.3	0.8	2.1	6.3
Approximate Shipping Weight (Kilograms)			34	45	113	227	295
FLOW CAPACITIES (L/S) GLOBE & ANGLE							
K_v - Globe (m^3/h @ 1 bar)			52	130	216	437	852
K_v - Angle (m^3/h @ 1 bar)			-	130	216	484	-
Continuous (Globe)			19	37	65	145	259
Intermittent (Globe)			24	44	75	170	295
Momentary (Globe)			36	78	136	303	530
MAXIMUM PRESSURE RATINGS (DUCTILE ONLY)							
Bar	FNPT		-	-	-	-	-
Bar	PN16		16	16	16	16	16
Bar ¹	PN25		25	25	25	25	25
MAXIMUM TEMPERATURE							
Celcius			82°	82°	82°	82°	82°

¹Valves rated and stamped 27.6 bar as standard. Valves rated and stamped 41 bar on request.

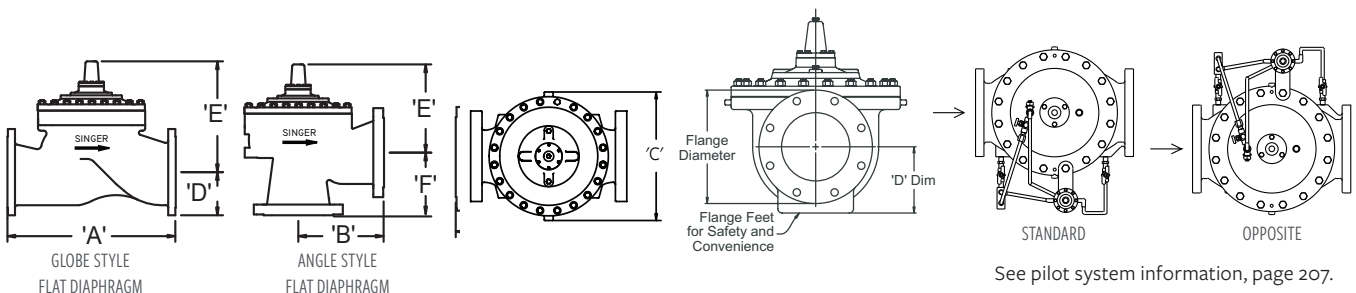

See pilot system information, page 207.
For additional Engineering notes, see page 242.

MODEL 206-PT / 206-PTC / S206-PT / S206-PTC

Double Chamber Hydraulically Operated Valve

ISO VALVE DATA (METRIC UNITS)

SIZE	DWG	STANDARD	ROLLING DIAPHRAGM SYSTEM									
			MM	REF	ISO	300 MM	400 MM	450 MM	500 MM	600 X 400 MM	600 X 500 MM	700 MM
GLOBE DIMENSIONS			ALL FIGURES SHOWN IN MM UNLESS OTHERWISE STATED									
Lay Length	A	BSPT	-	-	-	-	-	-	-	-	-	-
Centerline to Bottom	D	BSPT	-	-	-	-	-	-	-	-	-	-
Lay Length	A	PN10 / PN16	699	914	1067	1143	1283	1562	1607	1776	1776	
Centerline to Bottom	D	PN10 / PN16	241	298	318	354	419	435	499	526	588	
Lay Length	A	PN25 / PN40	699	956	1108	1184	1327	1607				
Centerline to Bottom	D	PN25 / PN40	241	324	356	387	457	499				
ANGLE DIMENSIONS												
Center Inlet to Discharge	B	BSPT	-	-	-	-	-	-	-	-	-	-
Center Discharge to Inlet	F	BSPT	-	-	-	-	-	-	-	-	-	-
Center Inlet to Discharge	B	PN10 / PN16	-	-	-	-	-	-	-	-	-	-
Center Discharge to Inlet	F	PN10 / PN16	-	-	-	-	-	-	-	-	-	-
Center Inlet to Discharge	B	PN25 / PN40	-	-	-	-	-	-	-	-	-	-
Center Discharge to Inlet	F	PN25 / PN40	-	-	-	-	-	-	-	-	-	-
COMMON DIMENSIONS GLOBE												
Width	C		562	660	800	775	914	914	1262	1262	1262	
Height (To Stem Cap) Globe	E		575	686	822	822	822.00	1060.00	1162	1162	1162	
Height (To Stem Cap) Angle	E		-	-	-	-	-	-	-	-	-	-
Body Port Tapping	FNPT	Inches	3/4	3/4	3/4	3/4	3/4	3/4	3/4	3/4	3/4	3/4
Stem Cap Plug	MNPT	Inches	3/4	3/4	3/4	3/4	3/4	3/4	3/4	3/4	3/4	3/4
Cover Port Tapping	FNPT	Inches	3/4	3/4	3/4	3/4	3/4	3/4	3/4	3/4	3/4	3/4
Valve Stroke		mm	83	95	120	120	120	141	150	150	150	
Displaced Bonnet Volume (Litres)			6	9	26	26	26	34	56	56	56	
Approximate Shipping Weight (Kilograms)			408	635	1089	1179	1270	1470	2721	2993	3175	
FLOW CAPACITIES (L/S) GLOBE												
K _v - Globe (m ³ /h @ 1 bar)			1341	1903	2855	2941	3028	4412	6920	1870	1890	
K _v - Angle (m ³ /h @ 1 bar)			-	-	-	-	-	-	-	-	-	-
Continuous (Globe)			404	582	1041	1041	1041	1370	2120	2126	2132	
Intermittent (Globe)			465	661	1320	1320	1320	1640	2362	2368	2375	
Momentary (Globe)			833	1211	1893	1896	1899	2460	4255	4261	4267	
MAXIMUM PRESSURE RATINGS (DUCTILE ONLY)												
Bar		BSPT	-	-	-	-	-	-	-	-	-	-
Bar		PN16	16	16	16	16	16	16	16	16	16	16
Bar		PN25	25	25	25	25	25	25	25	25	25	25
MAXIMUM TEMPERATURE												
Celcius			82°	82°	82°	82°	82°	82°	82°	82°	82°	82°

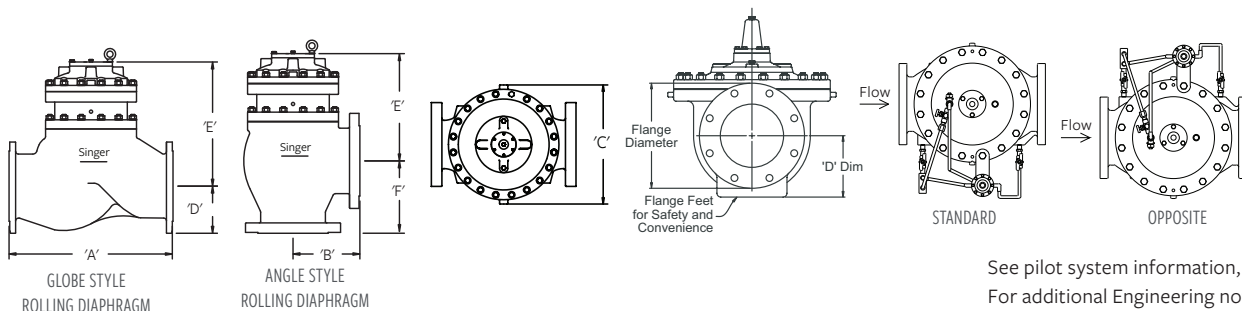

See pilot system information, page 207.
For additional Engineering notes, see page 242.

MODEL 106-PGM / S106-PGM

Integral Back-Up, Dual Diaphragm, Hydraulically Operated Valve

KEY FEATURES

- Ideal for applications requiring redundant and back-up security
- Virtually uninterrupted control under a variety of system failures
- Remote annunciation option available
- Available in globe and angle style

PRODUCT OVERVIEW

The 106-PGM and S106-PGM series valves are designed for particularly sensitive applications or situations where valves are difficult to access and maintain.

The PGM series valves provide integral back-up control and the ability to signal should the desired function move off limits. It can also provide an independent and very positive override.

It is a variation of the standard single chamber 106-PG valve with modifications that add the following features:

- Back-up diaphragm
- Completely self-contained
- Modulating or emergency close back-up
- Back-up components kept out of the main stream until required
- Extremely positive shut-off
- Emergency close for security breach or earthquake

With SRD technology the valve becomes incredibly steady throughout a complete range of flows and eradicates the need of additional low flow bypass valves.

The PGM series valves may be combined with additional Singer® specific accessories to add further customization such as:

- Back-up pilot system
- Annunciation with an Single Pole Double Throw Limit Switch

Refer to Main Valve Options on page 62 and Pilots & Accessories on page 207 to customize the valve to suit specific applications.



ALTERNATIVE MODELS



106-PGM ANGLE

MODEL 106-PGM / S106-PGM

Integral Back-Up, Dual Diaphragm, Hydraulically Operated Valve

PRODUCT LINE DRAWING

ID	PART NAME
1	Primary Stem / Position Indicator
2	Secondary Stem
3	ASTM A536 Ductile Iron Construction
4	Buna-N or EPDM Secondary Diaphragm
5	Back-up Secondary Assembly
6	Open to Atmosphere
7	Sliding guide
8	Buna-N / EPDM Primary Diaphragm
9	Buna-N or EPDM Resilient Disc
10	AISI 316 Stainless Steel Seat
11	AISI 316 Stainless Steel Stem
12	NSF 61 Fusion Bonded Epoxy Coating

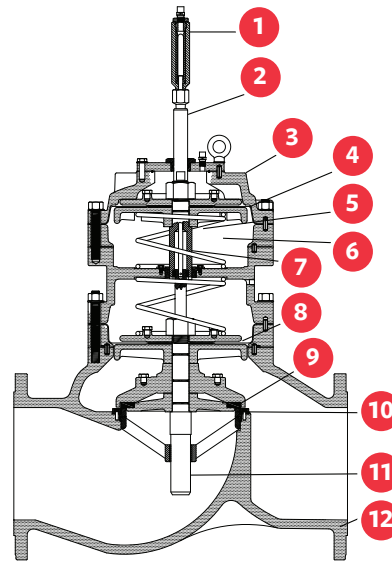

SELECTION

The Singer® Model 106-PGM incorporates a second actuator. If the primary system and/or the main valve fails then the back-up pilot system takes over. Under normal operating conditions, there is no external discharge from the PGM. In modulating applications, when the back-up pilot system operates, there is a small (less than 1 USGPM / 0.06 L/s) continuous discharge that should be taken to drain.

The primary pilot function can be duplicated in the secondary pilot system to provide continuing back-up operations or the secondary system can be used for override functions. Consult with us with your specific application requirements.

Sizing of PGM valves are based on the same criteria as standard PG models.

VALVE SIZES & MATERIALS

VALVE MATERIALS

Available Sizes	Standard		Optional
	Threaded	Flanged	
Globe	3" (80 mm)	3" to 24" (80 - 600 mm)	-
Angle	3" (80 mm)	3" to 12", 16" (80 - 300 mm, 400 mm)	-

VALVE COMPONENTS

Component	Standard	Optional
1. Valve Body, Cover	65-45-12 Ductile Iron	316 Stainless Steel (limited sizes)
2. Seat Ring	316 Stainless Steel	-
3. Disc Retainer	B16 Brass / B62 Bronze / A536 Ductile Iron	316 Stainless Steel
4. Stem	316 Stainless Steel	-
5. Stem Nut	B16 Brass	316 Stainless Steel
6. Spring	316 Stainless Steel	-
7. Guide Bushings	B16 Brass or SAE 660 Bronze	316 Stainless Steel
8. Diaphragm	EPDM	Buna-N / Viton (limited sizes)
9. Resilient Disc	EPDM	Buna-N / Viton (limited sizes)
10. Coating	NSF61 Approved Fusion Bonded Epoxy - Thickness 10-14 mils (250-350 microns)	Consult factory
11. Fasteners	18-8 Stainless Steel	316 Stainless Steel

MODEL 106-PGM / S106-PGM

Integral Back-Up, Dual Diaphragm, Hydraulically Operated Valve

AVAILABLE OPTIONS

Further customize the valve by adding any of the available options below.

MAIN VALVE OPTIONS, REFER TO PAGE 62

Position Indicators (Available for install at Singer® manufacturing or as a field modification)

- Model X129 limit switch assembly with Single Pole Double Throw limit switch (Double Pole Double Throw optional)
- Model X156 analog position transmitters (4-20 mA)

Oxy-Nitride Stem

Grooved Ends

Internal Drop Check

Reclaimed Water

PILOTS & ACCESSORIES, REFER TO PAGE 207

MATERIALS OF CONSTRUCTION

Individual components can be upgraded from ductile iron, bronze and brass to stainless steel, for most sizes. Consult with us.

ANTI-CAVITATION TRIM

Model 106-AC allows very high pressure drops in one valve, while retaining the standard 106 valve features. See page 78.

ORDERING INSTRUCTIONS

Refer to page 244 for the order form and ordering instructions.

MODEL 106-PGM / S106-PGM

Integral Back-Up, Dual Diaphragm, Hydraulically Operated Valve

ANSI VALVE DATA (US UNITS)

SIZE	DWG	STANDARD	FLAT DIAPHRAGM SYSTEM			
INCHES	REF	ANSI	3"	4"	6"	8"
GLOBE DIMENSIONS			ALL FIGURES SHOWN IN INCHES UNLESS OTHERWISE STATED			
Lay Length	A	FNPT	13.50	-	-	-
Centerline to Bottom	D	FNPT	3.68	-	-	-
Lay Length	A	150F	12.00	15.00	20.00	25.38
Centerline to Bottom	D	150F	3.75	4.60	5.60	7.88
Lay Length	A	300F	13.25	15.63	21.00	26.38
Centerline to Bottom	D	300F	4.13	5.09	6.34	7.88
ANGLE DIMENSIONS						
Center Inlet to Discharge	B	FNPT	6.63	-	-	-
Center Discharge to Inlet	F	FNPT	4.63	-	-	-
Center Inlet to Discharge	B	150F	6.06	7.50	10.00	12.75
Center Discharge to Inlet	F	150F	4.06	5.00	6.00	8.00
Center Inlet to Discharge	B	300F	6.43	7.88	10.50	13.25
Center Discharge to Inlet	F	300F	4.43	5.31	6.50	8.50
COMMON DIMENSIONS (GLOBE & ANGLE)						
Width	C		9.25	10.88	16.75	21.63
Height (To Indicator) Globe	E		17.63	19.43	21.00	26.88
Height (To Indicator) Angle	E		17.63	19.13	20.63	27.38
Body Port Tapping		FNPT	$\frac{3}{8}$	$\frac{3}{8}$	$\frac{3}{8}$	$\frac{1}{2}$
Stem Cap Plug		MNPT	$\frac{3}{8}$	$\frac{3}{8}$	$\frac{3}{8}$	$\frac{3}{8}$
Cover Port Tapping		FNPT	$\frac{3}{8}$	$\frac{3}{8}$	$\frac{1}{2}$	$\frac{1}{2}$
Valve Stroke			$1 \frac{1}{8}$	$1 \frac{1}{16}$	$1 \frac{11}{16}$	$2 \frac{7}{8}$
Displaced Bonnet Volume (Gallons)			0.1	0.2	0.6	1.7
Approximate Shipping Weight (Lbs)			150	210	450	705
FLOW CAPACITIES (USGPM) GLOBE & ANGLE						
C_v - Globe			110	200	460	800
C_v - Angle			135	230	535	950
Continuous (Globe)			460	800	1800	3100
Intermittent (Globe)			575	1000	2250	3875
Momentary (Globe)			1030	1800	4000	7000
MAXIMUM PRESSURE RATINGS (DUCTILE ONLY)						
psi ¹		FNPT	400	-	-	-
psi		150F	250	250	250	250
psi ¹		300F	400	400	400	400
MAXIMUM TEMPERATURE						
Fahrenheit			180°	180°	180°	180°

¹Valves rated and stamped 400 psi as standard. Valves rated and stamped 600 psi on request.

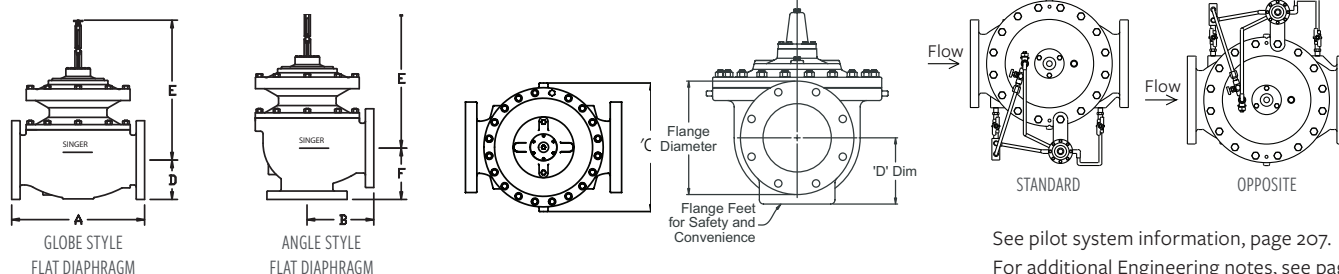

See pilot system information, page 207.
For additional Engineering notes, see page 242.

MODEL 106-PGM / S106-PGM

Integral Back-Up, Dual Diaphragm, Hydraulically Operated Valve

ANSI VALVE DATA (US UNITS)

SIZE	DWG	STANDARD	ROLLING DIAPHRAGM SYSTEM								
			INCHES	REF	ANSI	6"	8"	10"	12"	14"	16"
GLOBE DIMENSIONS			ALL FIGURES SHOWN IN INCHES UNLESS OTHERWISE STATED.								
Lay Length	A	FNPT	-	-	-	-	-	-	-	-	-
Centerline to Bottom	D	FNPT	-	-	-	-	-	-	-	-	-
Lay Length	A	150F	20.00	25.38	29.75	34.00	31.00	41.38	52.00	61.50	
Centerline to Bottom	D	150F	5.60	7.63	8.56	9.50	10.50	11.75	14.43	17.13	
Lay Length	A	300F	21.00	26.38	31.12	35.50	32.50	43.50	53.62	63.25	
Centerline to Bottom	D	300F	6.34	7.88	9.31	10.25	11.50	12.75	15.75	19.65	
ANGLE DIMENSIONS											
Center Inlet to Discharge	B	FNPT	-	-	-	-	-	-	-	-	
Center Discharge to Inlet	F	FNPT	-	-	-	-	-	-	-	-	
Center Inlet to Discharge	B	150F	10.00	12.75	11.50	13.75	-	18.00	-	-	
Center Discharge to Inlet	F	150F	6.00	8.00	12.50	12.50	-	15.69	-	-	
Center Inlet to Discharge	B	300F	10.50	13.25	12.19	14.50	-	18.81	-	-	
Center Discharge to Inlet	F	300F	6.50	8.50	13.19	13.25	-	16.50	-	-	
COMMON DIMENSIONS (GLOBE AND ANGLE)											
Width	C		12.75	17.25	22.13	26.00	26.00	32.00	35.00	49.68	
Height (To Indicator) Globe	E		25.5	33.5	39.38	44.50	44.63	52.13	59.50	61.50	
Height (To Indicator) Angle	E		25.5	33.5	36.00	41.50	-	49.13	-	-	
Body Port Tapping		FNPT	3/8	1/2	1/2	3/4	3/4	3/4	3/4	3/4	
Stem Cap Plug		MNPT	3/8	3/8	3/4	3/4	3/4	3/4	3/4	3/4	
Cover Port Tapping		FNPT	1/2	1/2	3/4	3/4	3/4	3/4	3/4	3/4	
Valve Stroke			1 1/16	2 7/8	3 1/4	3 3/4	3 3/4	4 3/4	5 9/16	6	
Displaced Bonnet Volume (Gallons)			0.50	1.00	1.5	2.3	2.3	6.8	9.0	14.8	
Approximate Shipping Weight (Lbs)			400	750	1000	1365	1500	2600	4315	7500	
FLOW CAPACITIES (USGPM) GLOBE & ANGLE											
C _v - Globe			460	800	1300	2100	2575	3300	5100	7600	
C _v - Angle			535	950	1400	2450	-	4000	-	-	
Continuous (Globe)			1800	3100	4900	7000	8500	11000	17500	25000	
Intermittent (Globe)			2250	3875	6100	8800	11500	14250	21700	31200	
Momentary (Globe)			4000	7000	11000	16000	19000	25000	39000	56200	
MAXIMUM PRESSURE RATINGS (DUCTILE ONLY)											
psi ¹		FNPT	-	-	-	-	-	-	-	-	
psi		150F	250	250	250	250	250	250	250	250	
psi ¹		300F	400	400	400	400	400	400	400	400	
MAXIMUM TEMPERATURE											
Fahrenheit			180°	180°	180°	180°	180°	180°	180°	180°	

¹Valves rated and stamped 400 psi as standard. Valves rated and stamped 600 psi on request.

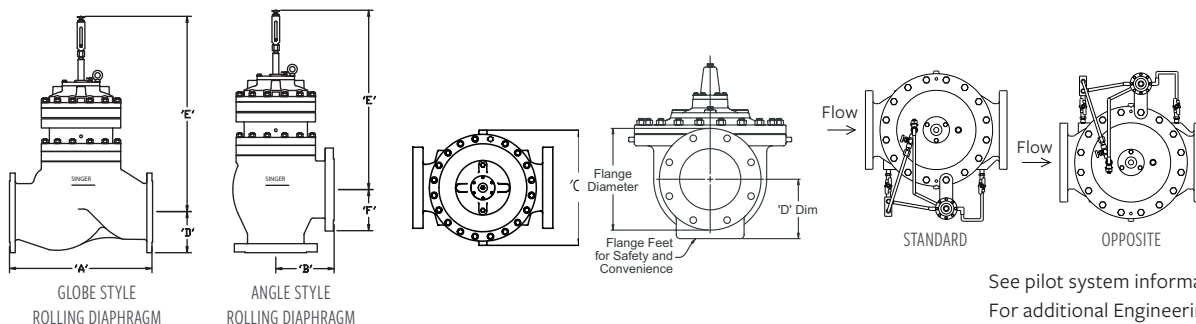

See pilot system information, page 207.
For additional Engineering notes, see page 242.

MODEL 106-PGM / S106-PGM

Integral Back-Up, Dual Diaphragm, Hydraulically Operated Valve

ANSI VALVE DATA (METRIC UNITS)

SIZE	DWG	STANDARD	FLAT DIAPHRAGM SYSTEM			
MM	REF	ANSI	80 MM	100 MM	150 MM	200 MM
GLOBE DIMENSIONS			ALL FIGURES SHOWN IN MM UNLESS OTHERWISE STATED			
Lay Length	A	FNPT	343	-	-	-
Centerline to Bottom	D	FNPT	93	-	-	-
Lay Length	A	150F	305	381	508	645
Centerline to Bottom	D	150F	95	117	142	200
Lay Length	A	300F	337	397	533	670
Centerline to Bottom	D	300F	105	129	161	200
ANGLE DIMENSIONS						
Center Inlet to Discharge	B	FNPT	168	-	-	-
Center Discharge to Inlet	F	FNPT	118	-	-	-
Center Inlet to Discharge	B	150F	154	191	254	324
Center Discharge to Inlet	F	150F	103	127	152	203
Center Inlet to Discharge	B	300F	163	200	267	337
Center Discharge to Inlet	F	300F	113	135	165	216
COMMON DIMENSIONS (GLOBE & ANGLE)						
Width	C		235	276	425	549
Height (To Indicator) Globe	E		448	494	533	683
Height (To Indicator) Angle	E		448	486	524	695
Body Port Tapping	FNPT	Inches	$\frac{3}{8}$	$\frac{3}{8}$	$\frac{3}{8}$	$\frac{1}{2}$
Stem Cap Plug	MNPT	Inches	$\frac{3}{8}$	$\frac{3}{8}$	$\frac{3}{8}$	$\frac{3}{8}$
Cover Port Tapping	FNPT	Inches	$\frac{3}{8}$	$\frac{3}{8}$	$\frac{1}{2}$	$\frac{1}{2}$
Valve Stroke		mm	29	37	43	73
Displaced Bonnet Volume (Litres)			0.3	0.8	2.1	6.3
Approximate Shipping Weight (Kilograms)			68	95	204	320
FLOW CAPACITIES (L/S) (GLOBE & ANGLE)						
K_v - Globe (m^3/h @ 1 bar)			95	173	398	692
K_v - Angle (m^3/h @ 1 bar)			117	199	463	822
Continuous (Globe)			29	50	114	196
Intermittent (Globe)			36	63	142	244
Momentary (Globe)			65	114	252	442
MAXIMUM PRESSURE RATINGS (DUCTILE ONLY)						
Bar ¹		FNPT	27.6	-	-	-
Bar		150F	17	17	17	17
Bar ¹		300F	27.6	27.6	27.6	27.6
MAXIMUM TEMPERATURE						
Celsius			82°	82°	82°	82°

¹Valves rated and stamped 27.6 bar as standard. Valves rated and stamped 41 bar on request.

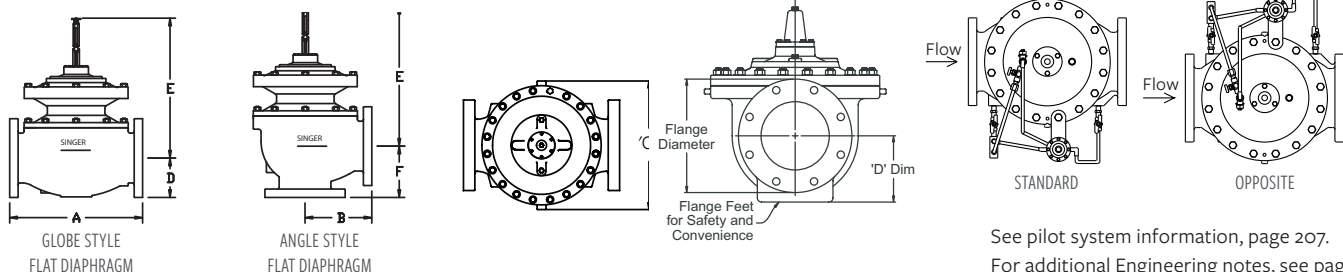

See pilot system information, page 207.
For additional Engineering notes, see page 242.

MODEL 106-PGM / S106-PGM

Integral Back-Up, Dual Diaphragm, Hydraulically Operated Valve

ANSI VALVE DATA (METRIC UNITS)

SIZE	DWG	STANDARD	ROLLING DIAPHRAGM SYSTEM							
MM	REF	ANSI	150 MM	200 MM	250 MM	300 MM	350 MM	400 MM	500 MM	600 MM
GLOBE DIMENSIONS			ALL FIGURES SHOWN IN MM UNLESS OTHERWISE STATED							
Lay Length	A	FNPT	-	-	-	-	-	-	-	-
Centerline to Bottom	D	FNPT	-	-	-	-	-	-	-	-
Lay Length	A	150F	508	645	756	864	787	1051	1321	1562
Centerline to Bottom	D	150F	142	200	217	241	267	298	367	435
Lay Length	A	300F	533	670	790	902	826	1105	1362	1607
Centerline to Bottom	D	300F	161	200	236	260	292	324	400	499
ANGLE DIMENSIONS										
Center Inlet to Discharge	B	FNPT	-	-	-	-	-	-	-	-
Center Discharge to Inlet	F	FNPT	-	-	-	-	-	-	-	-
Center Inlet to Discharge	B	150F	254	324	292	349	-	457	-	-
Center Discharge to Inlet	F	150F	152	203	318	318	-	399	-	-
Center Inlet to Discharge	B	300F	267	337	310	368	-	478	-	-
Center Discharge to Inlet	F	300F	165	216	335	337	-	419	-	-
COMMON DIMENSIONS (GLOBE & ANGLE)										
Width	C		324	438	562	660	660	813	889	1262
Height (To Indicator) Globe	E		650	850	1000	1130	1134	1324	1551	1562
Height (To Indicator) Angle	E		650	850	914	1054	-	1248	-	-
Body Port Tapping	FNPT	Inches	3/8	1/2	1/2	3/4	3/4	3/4	3/4	3/4
Stem Cap Plug	MNPT	Inches	3/8	3/8	3/4	3/4	3/4	3/4	3/4	3/4
Cover Port Tapping	FNPT	Inches	1/2	1/2	3/4	3/4	3/4	3/4	3/4	3/4
Valve Stroke		mm	43	73	83	95	95	120	141	150
Displaced Bonnet Volume (Litres)			2	4	6	9	9	26	34	56
Approximate Shipping Weight (Kilograms)			180	340	454	619	680	1179	1957	3400
FLOW CAPACITIES (L/S) (GLOBE & ANGLE)										
K _v - Globe (m ³ /h @ 1 bar)			398	692	1125	1817	2227	2855	4412	6574
K _v - Angle (m ³ /h @ 1 bar)			463	822	1211	2119	-	3460	-	-
Continuous (Globe)			114	196	309	442	536	694	1104	1577
Intermittent (Globe)			142	244	385	555	726	899	1370	1968
Momentary (Globe)			252	442	694	1009	1199	1577	2460	3546
MAXIMUM PRESSURE RATINGS (DUCTILE ONLY)										
Bar ¹	FNPT		-	-	-	-	-	-	-	-
Bar	150F		17	17	17	17	17	17	17	17
Bar ¹	300F		27.6	27.6	27.6	27.6	27.6	27.6	27.6	27.6
MAXIMUM TEMPERATURE										
Celcius			82°	82°	82°	82°	82°	82°	82°	82°

¹Valves rated and stamped 27.6 bar as standard. Valves rated and stamped 41 bar on request.

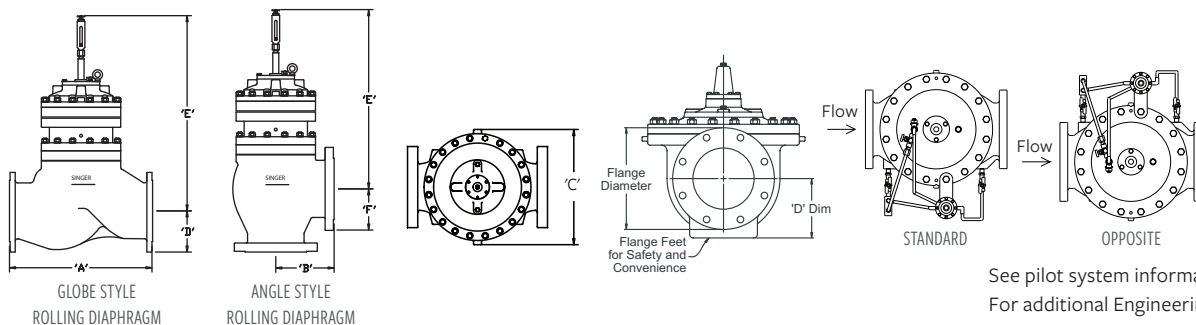

See pilot system information, page 207.
For additional Engineering notes, see page 242.

MODEL 106-PGM / S106-PGM

Integral Back-Up, Dual Diaphragm, Hydraulically Operated Valve

ISO VALVE DATA (METRIC UNITS)

SIZE	DWG	STANDARD	FLAT DIAPHRAGM SYSTEM			
MM	REF	ISO	80 MM	100 MM	150 MM	200 MM
GLOBE DIMENSIONS			ALL FIGURES SHOWN IN MM UNLESS OTHERWISE STATED			
Lay Length	A	BSPT	343	-	-	-
Centerline to Bottom	D	BSPT	93	-	-	-
Lay Length	A	PN10 / PN16	305	381	508	645
Centerline to Bottom	D	PN10 / PN16	95	117	142	200
Lay Length	A	PN25 / PN40	337	397	533	670
Centerline to Bottom	D	PN25 / PN40	105	129	161	200
ANGLE DIMENSIONS						
Center Inlet to Discharge	B	BSPT	168	-	-	-
Center Discharge to Inlet	F	BSPT	118	-	-	-
Center Inlet to Discharge	B	PN10 / PN16	154	191	254	324
Center Discharge to Inlet	F	PN10 / PN16	103	127	152	203
Center Inlet to Discharge	B	PN25 / PN40	163	200	267	337
Center Discharge to Inlet	F	PN25 / PN40	113	135	165	216
COMMON DIMENSIONS (GLOBE & ANGLE)						
Width	C		235	276	425	549
Height (To Indicator) Globe	E		448	494	533	683
Height (To Indicator) Angle	E		448	486	524	695
Body Port Tapping	FNPT	Inches	$\frac{3}{8}$	$\frac{3}{8}$	$\frac{3}{8}$	$\frac{1}{2}$
Stem Cap Plug	MNPT	Inches	$\frac{3}{8}$	$\frac{3}{8}$	$\frac{3}{8}$	$\frac{3}{8}$
Cover Port Tapping	FNPT	Inches	$\frac{3}{8}$	$\frac{3}{8}$	$\frac{1}{2}$	$\frac{1}{2}$
Valve Stroke		mm	29	37	43	73
Displaced Bonnet Volume (Litres)			0.3	0.8	2.1	6.3
Approximate Shipping Weight (Kilograms)			68	95	204	320
FLOW CAPACITIES (L/S) (GLOBE & ANGLE)						
K_v - Globe (m^3/h @ 1 bar)			95	173	398	692
K_v - Angle (m^3/h @ 1 bar)			117	199	463	822
Continuous (Globe)			29	50	114	196
Intermittent (Globe)			36	63	142	244
Momentary (Globe)			65	114	252	442
MAXIMUM PRESSURE RATINGS (DUCTILE ONLY)						
Bar		BSPT	27.6	-	-	-
Bar		PN16	16	16	16	16
Bar		PN25	25	25	25	25
MAXIMUM TEMPERATURE						
Celcius			82°	82°	82°	82°

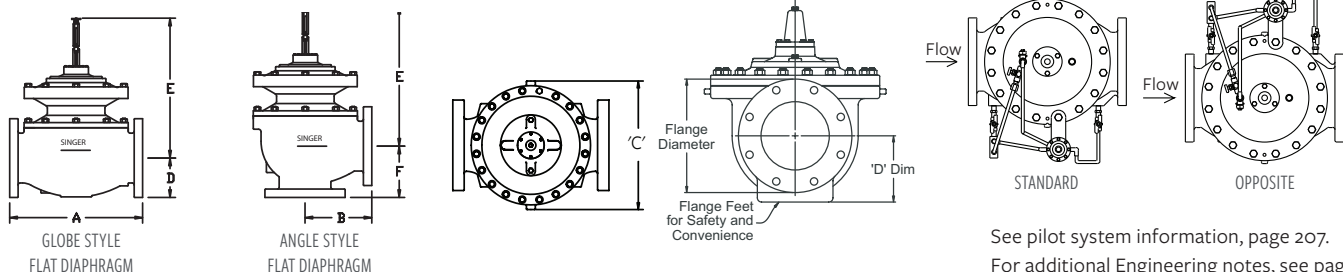

MODEL 106-PGM / S106-PGM

Integral Back-Up, Dual Diaphragm, Hydraulically Operated Valve

ANSI VALVE DATA (METRIC UNITS)

SIZE	DWG	STANDARD	ROLLING DIAPHRAGM SYSTEM								
			MM	REF	INSO	150 MM	200 MM	250 MM	300 MM	350 MM	400 MM
GLOBE DIMENSIONS			ALL FIGURES SHOWN IN MM UNLESS OTHERWISE STATED								
Lay Length	A	BSPT	-	-	-	-	-	-	-	-	-
Centerline to Bottom	D	BSPT	-	-	-	-	-	-	-	-	-
Lay Length	A	PN10 / PN16	508	645	756	864	787	1051	1321	1562	
Centerline to Bottom	D	PN10 / PN16	142	200	217	241	267	298	367	436	
Lay Length	A	PN25 / PN40	533	670	790	864	826	1105	1362	1607	
Centerline to Bottom	D	PN25 / PN40	161	200	243	241	292	324	400	499	
ANGLE DIMENSIONS											
Center Inlet to Discharge	B	BSPT	-	-	-	-	-	-	-	-	
Center Discharge to Inlet	F	BSPT	-	-	-	-	-	-	-	-	
Center Inlet to Discharge	B	PN10 / PN16	254	324	292	349	-	457	-	-	
Center Discharge to Inlet	F	PN10 / PN16	152	203	318	318	-	399	-	-	
Center Inlet to Discharge	B	PN25 / PN40	267	337	310	368	-	478	-	-	
Center Discharge to Inlet	F	PN25 / PN40	165	216	335	337	-	419	-	-	
COMMON DIMENSIONS (GLOBE & ANGLE)											
Width	C		324	438	562	660	660	813	889	1262	
Height (To Indicator) Globe	E		650	850	1000	1130	1134	1324	1511	1562	
Height (To Indicator) Angle	E		650	850	914	1054	-	1248	-	-	
Body Port Tapping	FNPT	Inches	3/8	1/2	1/2	3/4	3/4	3/4	3/4	3/4	
Stem Cap Plug	MNPT	Inches	3/8	3/8	3/4	3/4	3/4	3/4	3/4	3/4	
Cover Port Tapping	FNPT	Inches	1/2	1/2	3/4	3/4	3/4	3/4	3/4	3/4	
Valve Stroke		mm	43	73	83	95	95	120	141	150	
Displaced Bonnet Volume (Litres)			2	4	6	9	9	26	34	56	
Approximate Shipping Weight (Kilograms)			180	340	454	619	680	1179	1957	3400	
FLOW CAPACITIES (L/s) (GLOBE & ANGLE)											
K _v - Globe (m ³ /h @ 1 bar)			398	692	1125	1817	2227	2855	4412	6574	
K _v - Angle (m ³ /h @ 1 bar)			463	822	1211	2119	-	3460	-	-	
Continuous (Globe)			114	196	309	442	536	694	1104	1577	
Intermittent (Globe)			142	244	385	555	726	899	1370	1968	
Momentary (Globe)			252	442	694	1009	1199	1577	2460	3546	
MAXIMUM PRESSURE RATINGS (DUCTILE ONLY)											
Bar		BSPT	-	-	-	-	-	-	-	-	
Bar		PN16	16	16	16	16	16	16	16	16	
Bar		PN25	25	25	25	25	25	25	25	25	
MAXIMUM TEMPERATURE											
Celcius			82°	82°	82°	82°	82°	82°	82°	82°	

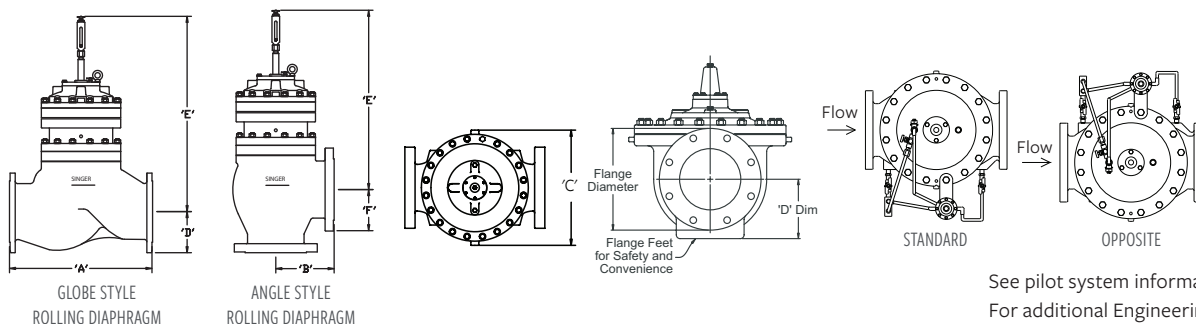

See pilot system information, page 207.
For additional Engineering notes, see page 242.

MODEL 206-PGM / S206-PGM

Integral Back-Up, Dual Diaphragm, Hydraulically Actuated Valve

KEY FEATURES

- Ideal for applications requiring redundant and/or back-up security
- Virtually uninterrupted control under a variety of system failures
- Remote annunciation option available
- Available in globe and angle style

PRODUCT OVERVIEW

The 206-PGM and S206-PGM valves are designed for particularly sensitive applications or situations where valves are difficult to access and maintain.

The PGM series valves provide integral back-up control and the ability to signal should the desired function move off limits. It can also provide an independent and very positive override.

It is a variation of the standard single chamber 206-PG valve with modifications that add the following features:

- Back-up diaphragm
- Completely self-contained
- Modulating or emergency close back-up
- Back-up components kept out of the main stream until required
- Extremely positive shut-off
- Emergency close for security breach or earthquake

The PGM series valves may be combined with additional our specific accessories to add further customization such as:

- Back-up pilot system
- Annunciation with a Single Pole Double Throw Limit Switch

Refer to Main Valve Options on page 62 and Pilots & Accessories on page 207 to customize the valve to suit specific applications.



ALTERNATIVE MODELS



A206-PGM ANGLE

MODEL 206-PGM / S206-PGM

Integral Back-Up, Dual Diaphragm, Hydraulically Actuated Valve

PRODUCT LINE DRAWING

ID	PART NAME
1	Primary Stem / Position Indicator
2	Secondary Stem
3	ASTM A536 Ductile Iron Construction
4	Buna-N or EPDM Secondary Diaphragm
5	Back-Up Secondary Assembly
6	Atmosphere
7	Sliding Guide
8	Buna-N or EPDM Primary Diaphragm
9	Buna-N or EPDM Resilient Disc
10	AISI 316 Stainless Steel Seat
11	AISI 316 Stainless Steel Stem
12	NSF 61 Fusion Bonded Epoxy Coating

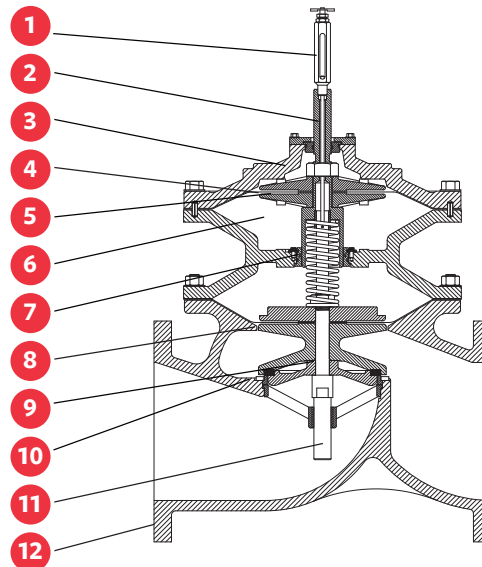

SELECTION

The Singer® Model 206-PGM incorporates a second actuator. If the primary system and/or the main valve fails then the back-up pilot system takes over. Under normal operating conditions, there is no external discharge from the PGM. In modulating applications, when the back-up pilot system operates, there is a small (less than 1 USGPM / 0.06 L/s) continuous discharge that should be taken to drain.

The primary pilot function can be duplicated in the secondary pilot system to provide continuing back-up operations or the secondary system can be used for override functions. Consult with us with your specific application requirements.

Sizing of PGM valves is based on the same criteria as standard PG models.

VALVE SIZES & MATERIALS

	VALVE MATERIALS	
	Standard	Optional
Available Sizes	Flanged	-
Globe	4" to 36" (100 - 900 mm)	-
Angle	4" to 8" (100 mm - 200 mm)	-
VALVE COMPONENTS		
1. Valve Body, Cover	65-45-12 Ductile Iron	-
2. Seat Ring	316 Stainless Steel	-
3. Disc Retainer	B16 Brass / B62 Bronze / A536 Ductile Iron	316 Stainless Steel
4. Stem	316 Stainless Steel	-
5. Stem Nut	B16 Brass	316 Stainless Steel
6. Spring	316 Stainless Steel	-
7. Guide Bushings	B16 Brass or SAE 660 Bronze	316 Stainless Steel
8. Diaphragm	EPDM	Buna-N / Viton (limited sizes)
9. Resilient Disc	EPDM	Buna-N / Viton (limited sizes)
10. Coating	NSF61 Approved Fusion Bonded Epoxy - Thickness 10-14 mils (250-350 microns)	-
11. Fasteners	18-8 Stainless Steel	316 Stainless Steel

MODEL 206-PGM / S206-PGM

Integral Back-Up, Dual Diaphragm, Hydraulically Actuated Valve

AVAILABLE OPTIONS

Further customize the valve by adding any of the available options below.

MAIN VALVE OPTIONS, REFER TO PAGE 62

Position Indicators (Available for install at Singer® manufacturing or as a field modification)

- Model X129 limit switch assembly with Single Pole Double Throw limit switch (Double Pole Double Throw optional)
- Model X156 analog position transmitters (4 - 20 mA)

Oxy-Nitride Stem

Grooved Ends

Internal Drop Check

Reclaimed Water

PILOTS & ACCESSORIES, REFER TO PAGE 207

MATERIALS OF CONSTRUCTION

Most individual components can be upgraded from ductile iron, bronze and brass to stainless steel. Consult with us.

ORDERING INSTRUCTIONS

Refer to page 244 for the order form and ordering instructions.

MODEL 206-PGM / S206-PGM

Integral Back-Up, Dual Diaphragm, Hydraulically Actuated Valve

VALVE DATA (US UNITS)

SIZE	DWG	STANDARD	FLAT DIAPHRAGM SYSTEM			
			INCHES	4"	6"	8"
GLOBE DIMENSIONS		ANSI	ALL FIGURES SHOWN IN INCHES UNLESS OTHERWISE STATED			
Lay Length	A	FNPT	-	-	-	-
Centerline to Bottom	D	FNPT	-	-	-	-
Lay Length	A	150F	15.00	20.13	25.00	24.50
Centerline to Bottom	D	150F	4.60	5.60	6.75	8.56
Lay Length	A	300F	15.63	21.00	26.00	25.88
Centerline to Bottom	D	300F	5.00	6.25	7.50	9.31
ANGLE DIMENSIONS						
Center Inlet to Discharge	B	FNPT	-	-	-	-
Center Discharge to Inlet	F	FNPT	-	-	-	-
Center Inlet to Discharge	B	150F	7.56	10.19	12.50	-
Center Discharge to Inlet	F	150F	5.94	6.19	9.00	-
Center Inlet to Discharge	B	300F	7.88	10.63	13.00	-
Center Discharge to Inlet	F	300F	6.25	6.81	9.50	-
COMMON DIMENSIONS (GLOBE & ANGLE)						
Width	C		10.00	12.50	16.00	20.00
Height (To Indicator) Globe	E		19.13	20.88	23.38	30.63
Height (To Indicator) Angle	E		17.38	19.25	20.50	-
Body Port Tapping		FNPT	$\frac{3}{8}$	$\frac{3}{8}$	$\frac{3}{8}$	$\frac{1}{2}$
Stem Cap Plug		MNPT	$\frac{3}{8}$	$\frac{3}{8}$	$\frac{3}{8}$	$\frac{3}{8}$
Cover Port Tapping		FNPT	$\frac{3}{8}$	$\frac{3}{8}$	$\frac{1}{2}$	$\frac{1}{2}$
Valve Stroke			$1 \frac{1}{8}$	$1 \frac{7}{16}$	$1 \frac{11}{16}$	$2 \frac{7}{8}$
Displaced Bonnet Volume (Gallons)			0.1	0.2	0.6	1.7
Approximate Shipping Weight (Lbs)			150.0	210.0	385.0	585.0
FLOW CAPACITIES (USGPM) GLOBE & ANGLE						
C_v - Globe			150	250	505	985
C_v - Angle			150	250	560	-
Continuous (Globe)			580	1025	2300	4100
Intermittent (Globe)			690	1190	2700	4670
Momentary (Globe)			1236	2160	4800	8400
MAXIMUM PRESSURE RATINGS (DUCTILE ONLY)						
psi		FNPT	-	-	-	-
psi		150F	250	250	250	250
psi ¹		300F	400	400	400	400
MAXIMUM TEMPERATURE						
Fahrenheit			180°	180°	180°	180°

¹Valves rated and stamped 400 psi as standard. Valves rated and stamped 600 psi on request.

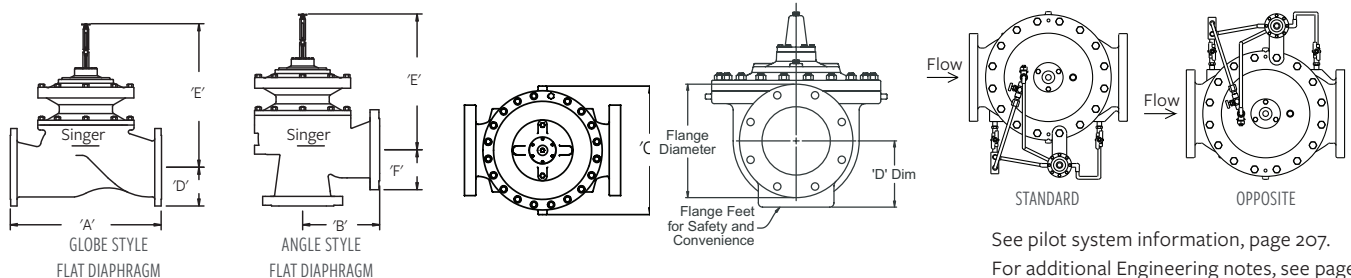

See pilot system information, page 207.
For additional Engineering notes, see page 242.

MODEL 206-PGM / S206-PGM

Integral Back-Up, Dual Diaphragm, Hydraulically Actuated Valve

ANSI VALVE DATA (US UNITS)

SIZE	DWG	STANDARD	ROLLING DIAPHRAGM SYSTEM											
			INCHES	REF	ANSI	8"	10"	12"	16"	18"	20"	24" X 16"	24" X 20"	30"
GLOBE DIMENSIONS			ALL FIGURES SHOWN IN INCHES UNLESS OTHERWISE STATED.											
Lay Length	A	FNPT	-	-	-	-	-	-	-	-	-	-	-	-
Centerline to Bottom	D	FNPT	-	-	-	-	-	-	-	-	-	-	-	-
Lay Length	A	150F	25.00	26.00	27.50	36.00	42.00	45.00	50.50	61.50	69.93	69.93		
Centerline to Bottom	D	150F	7.00	8.56	9.50	11.75	12.50	13.93	16.50	17.13	20.68	23.75		
Lay Length	A	300F	26.00	27.38	29.00	37.63	43.63	46.63	52.25	63.25	-	-		
Centerline to Bottom	D	300F	7.75	9.31	10.25	12.75	14.00	15.25	18.00	19.65	-	-		
ANGLE DIMENSIONS														
Center Inlet to Discharge	B	FNPT	-	-	-	-	-	-	-	-	-	-	-	-
Center Discharge to Inlet	F	FNPT	-	-	-	-	-	-	-	-	-	-	-	-
Center Inlet to Discharge	B	150F	-	-	-	-	-	-	-	-	-	-	-	-
Center Discharge to Inlet	F	150F	-	-	-	-	-	-	-	-	-	-	-	-
Center Inlet to Discharge	B	300F	-	-	-	-	-	-	-	-	-	-	-	-
Center Discharge to Inlet	F	300F	-	-	-	-	-	-	-	-	-	-	-	-
COMMON DIMENSIONS (GLOBE AND ANGLE)														
Width	C		15.00	17.75	22.13	26.00	31.50	31.50	36.00	36.00	49.75	49.75		
Height (To Indicator) Globe	E		25.00	32.50	39.38	44.56	53.00	53.00	53.00	59.50	61.50	61.50		
Height (To Indicator) Angle	E		-	-	-	-	-	-	-	-	-	-	-	-
Body Port Tapping		FNPT	3/8	1/2	3/4	3/4	3/4	3/4	3/4	3/4	3/4	3/4	3/4	3/4
Stem Cap Plug		MNPT	3/8	3/8	3/4	3/4	3/4	3/4	3/4	3/4	3/4	3/4	3/4	3/4
Cover Port Tapping		FNPT	3/8	3/8	3/4	3/4	3/4	3/4	3/4	3/4	3/4	3/4	3/4	3/4
Valve Stroke			1 1/16	1 7/8	3 1/4	3 3/4	4 3/4	4 3/4	4 3/4	5 9/16	6	6		
Displaced Bonnet Volume (Gallons)			0.5	1.0	1.5	2.3	6.8	6.8	6.8	9.0	14.8	14.8		
Approximate Shipping Weight (Lbs)			430	790	880	1540	2530	2730	2980	4750	7300	7500		
FLOW CAPACITIES (USGPM) GLOBE & ANGLE														
C _v - Globe			505	985	1550	2200	3300	3400	3500	5100	7800	8000		
C _v - Angle			-	-	-	-	-	-	-	-	-	-	-	-
Continuous (Globe)			2300	4100	6400	9230	16500	16500	16500	21700	33650	33800		
Intermittent (Globe)			2700	4670	7370	10470	20915	20915	20915	26000	37490	37640		
Momentary (Globe)			4800	8400	13200	19200	30000	30050	30100	39000	67490	67640		
MAXIMUM PRESSURE RATINGS (DUCTILE ONLY)														
psi		FNPT	-	-	-	-	-	-	-	-	-	-	-	-
psi		150F	250	250	250	250	250	250	250	250	250	250		
psi ¹		300F	400	400	400	400	400	400	400	400	400	400		
MAXIMUM TEMPERATURE														
Fahrenheit			180°	180°	180°	180°	180°	180°	180°	180°	180°	180°		

¹Valves rated and stamped 400 psi as standard. Valves rated and stamped 600 psi on request.

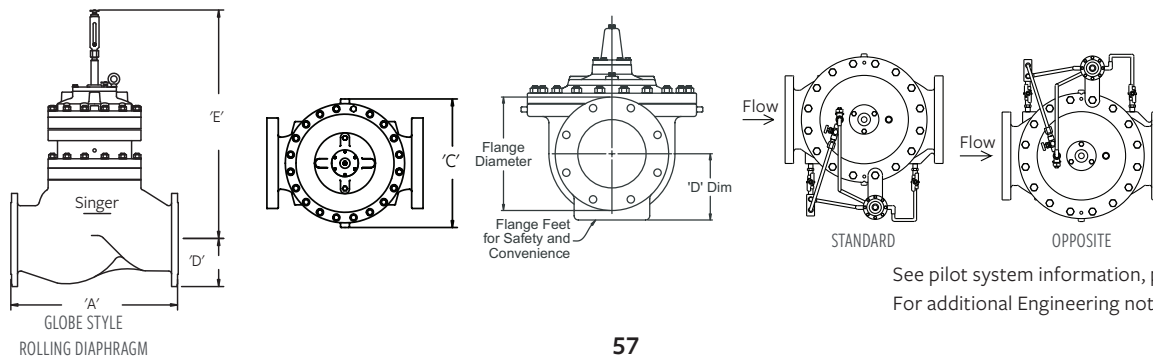

See pilot system information, page 207.

For additional Engineering notes, see page 242.

MODEL 206-PGM / S206-PGM

Integral Back-Up, Dual Diaphragm, Hydraulically Actuated Valve

ANSI VALVE DATA (METRIC UNITS)

SIZE	DWG	STANDARD	FLAT DIAPHRAGM SYSTEM			
			100 MM	150 MM	200 MM	250 MM
MM	REF	ANSI				
GLOBE DIMENSIONS			ALL FIGURES SHOWN IN MM UNLESS OTHERWISE STATED			
Lay Length	A	FNPT	-	-	-	-
Centerline to Bottom	D	FNPT	-	-	-	-
Lay Length	A	150F	381	511	635	622
Centerline to Bottom	D	150F	117	142	171	217
Lay Length	A	300F	397	533	660	657
Centerline to Bottom	D	300F	127	159	191	236
ANGLE DIMENSIONS						
Center Inlet to Discharge	B	FNPT	-	-	-	-
Center Discharge to Inlet	F	FNPT	-	-	-	-
Center Inlet to Discharge	B	150F	192	259	318	-
Center Discharge to Inlet	F	150F	151	157	229	-
Center Inlet to Discharge	B	300F	200	270	330	-
Center Discharge to Inlet	F	300F	159	173	241	-
COMMON DIMENSIONS (GLOBE & ANGLE)						
Width	C		254	318	406	508
Height (To Indicator) Globe	E		486	530	594	778
Height (To Indicator) Angle	E		441	489	521	-
Body Port Tapping	FNPT	Inches	$\frac{3}{8}$	$\frac{3}{8}$	$\frac{3}{8}$	$\frac{1}{2}$
Stem Cap Plug	MNPT	Inches	$\frac{3}{8}$	$\frac{3}{8}$	$\frac{3}{8}$	$\frac{3}{8}$
Cover Port Tapping	FNPT	Inches	$\frac{3}{8}$	$\frac{3}{8}$	$\frac{1}{2}$	$\frac{1}{2}$
Valve Stroke		mm	29	37	43	73
Displaced Bonnet Volume (Litres)			0.3	0.8	2.1	6.3
Approximate Shipping Weight (Kilograms)			68	95	175	265
FLOW CAPACITIES (L/S) GLOBE & ANGLE						
K_v - Globe (m^3/h @ 1 bar)			130	216	437	852
K_v - Angle (m^3/h @ 1 bar)			130	216	484	-
Continuous (Globe)			37	65	145	259
Intermittent (Globe)			44	75	170	295
Momentary (Globe)			78	136	303	530
MAXIMUM PRESSURE RATINGS (DUCTILE ONLY)						
Bar	FNPT		-	-	-	-
Bar	150F		17	17	17	17
Bar ¹	300F		27.6	27.6	27.6	27.6
MAXIMUM TEMPERATURE						
Celcius			82°	82°	82°	82°

¹Valves rated and stamped 27.6 bar as standard. Valves rated and stamped 41 bar on request.

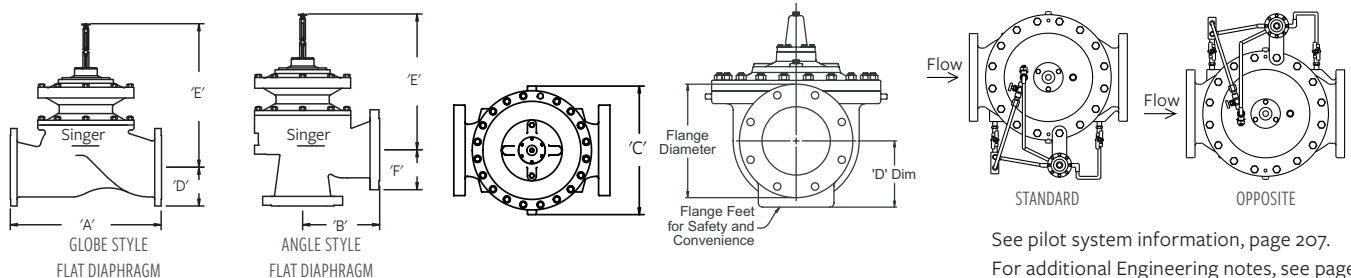

MODEL 206-PGM / S206-PGM

Integral Back-Up, Dual Diaphragm, Hydraulically Actuated Valve

ANSI VALVE DATA (METRIC UNITS)

SIZE	DWG	STANDARD	ROLLING DIAPHRAGM SYSTEM									
MM	REF	ANSI	200 MM	250 MM	300 MM	400 MM	450 MM	500 MM	600 X 400 MM	600 X 500 MM	750 MM	900 MM
GLOBE DIMENSIONS			ALL FIGURES SHOWN IN MM UNLESS OTHERWISE STATED.									
Lay Length	A	FNPT	-	-	-	-	-	-	-	-	-	-
Centerline to Bottom	D	FNPT	-	-	-	-	-	-	-	-	-	-
Lay Length	A	150F	635	660	699	914	1067	1143	1283	1562	1776	1776
Centerline to Bottom	D	150F	178	217	241	298	318	354	419	435	525	603
Lay Length	A	300F	660	695	737	956	1108	1184	1327	1607	-	-
Centerline to Bottom	D	300F	197	236	260	324	356	387	457	499	-	-
ANGLE DIMENSIONS												
Center Inlet to Discharge	B	FNPT	-	-	-	-	-	-	-	-	-	-
Center Discharge to Inlet	F	FNPT	-	-	-	-	-	-	-	-	-	-
Center Inlet to Discharge	B	150F	-	-	-	-	-	-	-	-	-	-
Center Discharge to Inlet	F	150F	-	-	-	-	-	-	-	-	-	-
Center Inlet to Discharge	B	300F	-	-	-	-	-	-	-	-	-	-
Center Discharge to Inlet	F	300F	-	-	-	-	-	-	-	-	-	-
COMMON DIMENSIONS (GLOBE & ANGLE)												
Width	C		381	450	562	660	800	800	914	914	1264	1264
Height (To Indicator) Globe	E		635	826	1000	1132	1346	1346	1346	1511	1162	1562
Height (To Indicator) Angle	E		-	-	-	-	-	-	-	-	-	-
Body Port Tapping	FNPT	Inches	3/8	3/8	3/4	3/4	3/4	3/4	3/4	3/4	3/4	3/4
Stem Cap Plug	MNPT	Inches	3/8	3/8	3/4	3/4	3/4	3/4	3/4	3/4	3/4	3/4
Cover Port Tapping	FNPT	Inches	3/8	3/8	3/4	3/4	3/4	3/4	3/4	3/4	3/4	3/4
Valve Stroke		mm	43	48	83	95	120	120	120	141	150	150
Displaced Bonnet Volume (Litres)			2.00	5.00	5.67	8.69	25.55	25.55	25.55	34.00	55.76	55.83
Approximate Shipping Weight (Kilograms)			195	360	399	699	1148	1238	1352	2155	2812	3400
FLOW CAPACITIES (L/S) GLOBE & ANGLE												
K _v - Globe (m ³ /h @ 1 bar)			437	852	1341	1903	2855	2941	3028	4412	6747	6920
K _v - Angle (m ³ /h @ 1 bar)			-	-	-	-	-	-	-	-	-	-
Continuous (Globe)			145	259	404	582	1041	1041	1041	1370	2120	2132
Intermittent (Globe)			170	295	465	661	1320	1320	1320	1640	2362	2375
Momentary (Globe)			303	530	833	1211	1893	1896	1899	2460	4255	4267
MAXIMUM PRESSURE RATINGS (DUCTILE ONLY)												
Bar	FNPT		-	-	-	-	-	-	-	-	-	-
Bar	150F		17	17	17	17	17	17	17	17	17	17
Bar ¹	300F		27.6	27.6	27.6	27.6	27.6	27.6	27.6	27.6	27.6	27.6
MAXIMUM TEMPERATURE												
Celcius			82°	82°	82°	82°	82°	82°	82°	82°	82°	82°

¹Valves rated and stamped 27.6 Bar as standard. Valves rated and stamped 41 Bar on request.

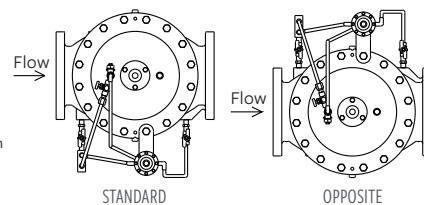
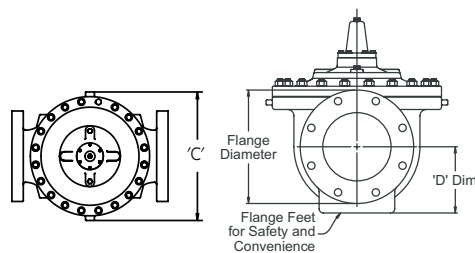
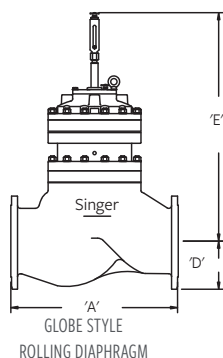

See pilot system information, page 207.

For additional Engineering notes, see page 242.

MODEL 206-PGM / S206-PGM

Integral Back-Up, Dual Diaphragm, Hydraulically Actuated Valve

ISO VALVE DATA (METRIC UNITS)

SIZE	DWG	STANDARD	FLAT DIAPHRAGM SYSTEM			
			100 MM	150 MM	200 MM	250 MM
MM	REF	ISO				
GLOBE DIMENSIONS			ALL FIGURES SHOWN IN MM UNLESS OTHERWISE STATED			
Lay Length	A	BSPT	-	-	-	-
Centerline to Bottom	D	BSPT	-	-	-	-
Lay Length	A	PN10 / PN16	381	511	635	622
Centerline to Bottom	D	PN10 / PN16	117	143	171	217
Lay Length	A	PN25 / PN40	397	533	660	657
Centerline to Bottom	D	PN25 / PN40	127	161	191	236
ANGLE DIMENSIONS						
Center Inlet to Discharge	B	BSPT	-	-	-	-
Center Discharge to Inlet	F	BSPT	-	-	-	-
Center Inlet to Discharge	B	PN10 / PN16	192	259	318	-
Center Discharge to Inlet	F	PN10 / PN16	151	157	229	-
Center Inlet to Discharge	B	PN25 / PN40	200	270	330	-
Center Discharge to Inlet	F	PN25 / PN40	159	173	241	-
COMMON DIMENSIONS (GLOBE & ANGLE)						
Width	C		254	318	406	508
Height (To Indicator) Globe	E		486	530	594	778
Height (To Indicator) Angle	E		441	489	521	-
Body Port Tapping	FNPT	Inches	$\frac{3}{8}$	$\frac{3}{8}$	$\frac{3}{8}$	$\frac{1}{2}$
Stem Cap Plug	MNPT	Inches	$\frac{3}{8}$	$\frac{3}{8}$	$\frac{3}{8}$	$\frac{3}{8}$
Cover Port Tapping	FNPT	Inches	$\frac{3}{8}$	$\frac{3}{8}$	$\frac{1}{2}$	$\frac{1}{2}$
Valve Stroke		mm	29	37	43	73
Displaced Bonnet Volume (Litres)			0.3	0.8	2.1	6.3
Approximate Shipping Weight (Kilograms)			68	95	175	265
FLOW CAPACITIES (L/S) GLOBE & ANGLE						
K_v - Globe (m^3/h @ 1 bar)			130	216	437	852
K_v - Angle (m^3/h @ 1 bar)			130	216	484	-
Continuous (Globe)			37	65	145	259
Intermittent (Globe)			44	75	170	295
Momentary (Globe)			78	136	303	530
MAXIMUM PRESSURE RATINGS						
Bar		BSPT	-	-	-	-
Bar		PN16	16	16	16	16
Bar		PN25	25	25	25	25
MAXIMUM TEMPERATURE						
Celcius			82°	82°	82°	82°

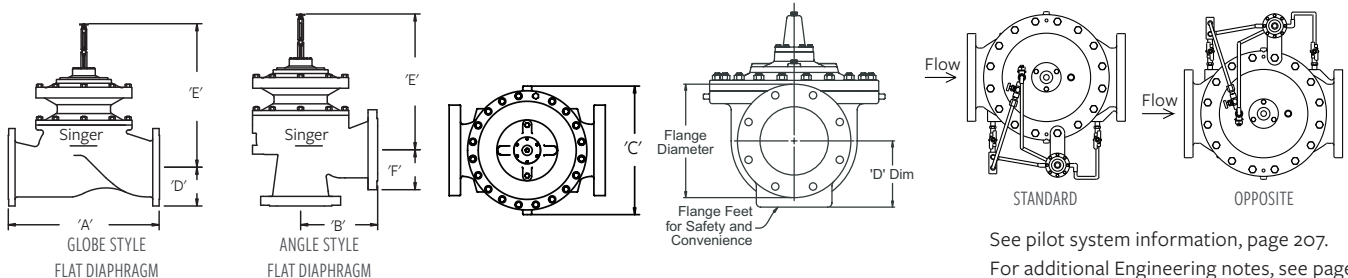

See pilot system information, page 207.
For additional Engineering notes, see page 242.

MODEL 206-PGM / S206-PGM

Integral Back-Up, Dual Diaphragm, Hydraulically Actuated Valve

ISO VALVE DATA (METRIC UNITS)

SIZE	DWG	STANDARD	ROLLING DIAPHRAGM SYSTEM												
			MM	REF	ISO	200 MM	250 MM	300 MM	400 MM	450 MM	500 MM	600 X 400 MM	600 X 500 MM	700 MM	800 MM
GLOBE DIMENSIONS			ALL FIGURES SHOWN IN MM UNLESS OTHERWISE STATED.												
Lay Length	A	BSPT	-	-	-	-	-	-	-	-	-	-	-	-	-
Centerline to Bottom	D	BSPT	-	-	-	-	-	-	-	-	-	-	-	-	-
Lay Length	A	PN10 / PN16	635	660	699	914	1067	1143	1283	1562	1607	1776	1776		
Centerline to Bottom	D	PN10 / PN16	178	217	241	298	318	354	419	435	499	526	603		
Lay Length	A	PN25 / PN40	660	695	737	956	1108	1184	1327	1607	-	-	-		
Centerline to Bottom	D	PN25 / PN40	197	236	267	324	356	387	457	499	-	-	-		
ANGLE DIMENSIONS															
Center Inlet to Discharge	B	BSPT	-	-	-	-	-	-	-	-	-	-	-	-	-
Center Discharge to Inlet	F	BSPT	-	-	-	-	-	-	-	-	-	-	-	-	-
Center Inlet to Discharge	B	PN10 / PN16	-	-	-	-	-	-	-	-	-	-	-	-	-
Center Discharge to Inlet	F	PN10 / PN16	-	-	-	-	-	-	-	-	-	-	-	-	-
Center Inlet to Discharge	B	PN25 / PN40	-	-	-	-	-	-	-	-	-	-	-	-	-
Center Discharge to Inlet	F	PN25 / PN40	-	-	-	-	-	-	-	-	-	-	-	-	-
COMMON DIMENSIONS (GLOBE & ANGLE)															
Width	C		381	450	562	660	795	800	914	914	1262	1262	1262		
Height (To Indicator) Globe	E		635	826	1000	1132	1346	1346	1346	1511	1562	1562	1562		
Height (To Indicator) Angle	E		-	-	-	-	-	-	-	-	-	-	-		
Body Port Tapping	FNPT	Inches	3/8	3/8	3/4	3/4	3/4	3/4	3/4	3/4	3/4	3/4	3/4	3/4	3/4
Stem Cap Plug	MNPT	Inches	3/8	3/8	3/4	3/4	3/4	3/4	3/4	3/4	3/4	3/4	3/4	3/4	3/4
Cover Port Tapping	FNPT	Inches	3/8	3/8	3/4	3/4	3/4	3/4	3/4	3/4	3/4	3/4	3/4	3/4	3/4
Valve Stroke		mm	43	48	83	95	120	120	120	141	150	150	150		
Displaced Bonnet Volume (Litres)			2	5	6	9	26	26	26	34	56	56	56		
Approximate Shipping Weight (Kilograms)			195	360	399	699	1148	1238	1352	2155	2812	2993	3175		
FLOW CAPACITIES (L/S) GLOBE & ANGLE															
K _v - Globe (m ³ /h @ 1 bar)			437	852	1341	1903	2855	2941	3028	4412	6661	6747	6920		
K _v - Angle (m ³ /h @ 1 bar)			-	-	-	-	-	-	-	-	-	-	-		
Continuous (Globe)			145	259	404	582	1041	1041	1041	1370	2120	2126	2132		
Intermittent (Globe)			170	295	465	661	1320	1320	1320	1640	2362	2368	2375		
Momentary (Globe)			303	530	833	1211	1893	1896	1899	2460	4255	4261	4267		
MAXIMUM PRESSURE RATINGS															
Bar	BSPT		-	-	-	-	-	-	-	-	-	-	-		
Bar	PN16		16	16	16	16	16	16	16	16	16	16	16		
Bar	PN25		25	25	25	25	25	25	25	25	25	25	25		
MAXIMUM TEMPERATURE															
Celcius			82°	82°	82°	82°	82°	82°	82°	82°	82°	82°	82°	82°	82°

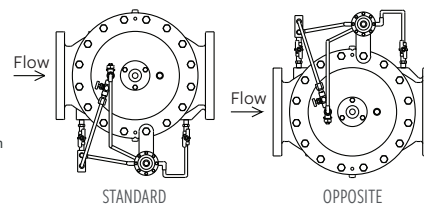
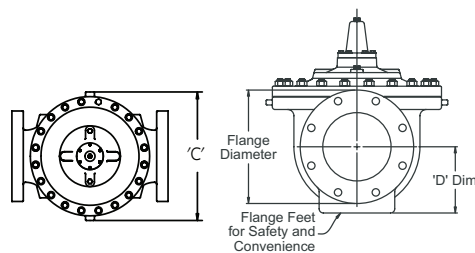
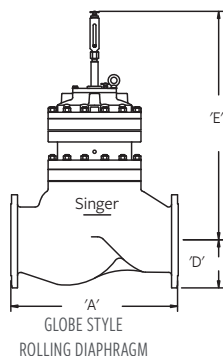

See pilot system information, page 207.
For additional Engineering notes, see page 242.

MODEL 106-GE / 206-GE

Grooved Ends

KEY FEATURES

- Convenient system and equipment access for ease of alignment and installation
- Improved flexibility with expansion, contraction and deflection
- Seismic stress absorption
- Eliminates unions

PRODUCT OVERVIEW

For use with grooved Iron Pipe Size (IPS) Pipe Coupling Products, grooved ends allows you to benefit from the simplicity and convenience of grooved end piping and fittings in an automatic control valve. There are a wide range of applications where grooved ends are relevant, but typical applications include municipal water, waste water, fire protection and plumbing.

Grooved ends come in the following size ranges:

- 2" / 50 mm – 8" / 200 mm
- Angle ranges from 2" / 50 mm – 3" / 80 mm

Standard cut groove specifications for steel and other IPS pipe will apply, unless otherwise specified



MODEL 106-GE / 206-GE

Grooved Ends

VALVE DATA (US UNITS)

INCHES	DWG	STANDARD	FLAT DIAPHRAGM SYSTEM						
	REF	GROOVED ENDS	2"	2 1/2"	3"	4"	6"	8"	8" (206)
GLOBE DIMENSIONS			ALL FIGURES SHOWN IN INCHES UNLESS OTHERWISE STATED						
Lay Length	A		9.38	11.63	13.25	15.00	20.00	25.38	26.00
Centerline to Bottom	D		2.75	3.25	3.68	4.00	5.60	7.50	4.63
COMMON DIMENSIONS (GLOBE)									
Width	C		6.00	8.19	9.25	10.88	16.75	21.63	16.00
Height (To Stem Cap) Globe	E		4.75	7.50	8.00	9.15	11.75	14.91	14.13
Body Port Tapping		FNPT	3/8	3/8	3/8	3/8	3/8	1/2	3/8
Stem Cap Plug		MNPT	3/8	3/8	3/8	3/8	3/8	3/8	3/8
Cover Port Tapping		FNPT	3/8	3/8	3/8	3/8	3/8	1/2	1/2
Valve Stroke			9/16	15/16	1 1/8	1 7/16	1 11/16	2 7/8	1 11/16
Displaced Bonnet Volume (Gallons)			0.02	0.07	0.1	0.2	0.6	1.7	0.6
Approximate Shipping Weight (Lbs)			40	65	100	175	400	650	500
FLOW CAPACITIES (USGPM) GLOBE									
C _v			55	80	110	200	460	800	505
Continuous (Globe)			210	300	460	800	1800	3100	2300
Intermittent (Globe)			260	375	575	1000	2250	3875	2700
Momentary (Globe)			470	670	1030	1800	4000	7000	4800
MAXIMUM PRESSURE RATINGS (DUCTILE ONLY)									
psi ¹		Grooved Ends	400	400	400	400	400	400	400
MAXIMUM TEMPERATURE									
Fahrenheit			180°	180°	180°	180°	180°	180°	180°

¹Valves rated and stamped 400 psi as standard. Valves rated and stamped 600 psi on request.

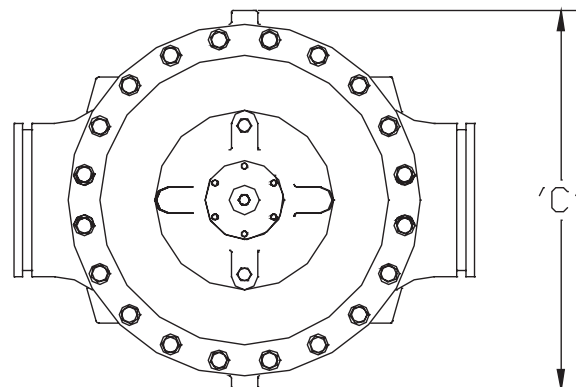
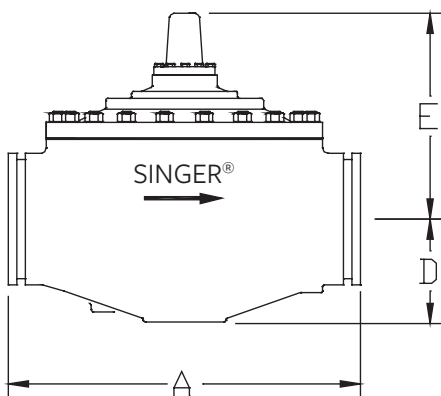

MODEL 106-GE / 206-GE

Grooved Ends

VALVE DATA (METRIC UNITS)

MM	DWG	STANDARD	FLAT DIAPHRAGM SYSTEM						
	REF	GROOVED ENDS	50 MM	65 MM	80 MM	100 MM	150 MM	200 MM	200 MM (206)
GLOBE DIMENSIONS			ALL FIGURES SHOWN IN MILLIMETERS UNLESS OTHERWISE STATED						
Lay Length	A		238	295	337	381	508	645	660
Centerline to Bottom	D		70	83	93	102	142	191	118
COMMON DIMENSIONS (GLOBE)									
Width	C		152	208	235	276	425	549	406
Height (To Stem Cap) Globe	E		121	191	203	232	298	379	359
Body Port Tapping	FNPT	Inches	$\frac{3}{8}$	$\frac{3}{8}$	$\frac{3}{8}$	$\frac{3}{8}$	$\frac{3}{8}$	$\frac{1}{2}$	$\frac{3}{8}$
Stem Cap Plug	MNPT	Inches	$\frac{3}{8}$	$\frac{3}{8}$	$\frac{3}{8}$	$\frac{3}{8}$	$\frac{3}{8}$	$\frac{3}{8}$	$\frac{3}{8}$
Cover Port Tapping	FNPT	Inches	$\frac{3}{8}$	$\frac{3}{8}$	$\frac{3}{8}$	$\frac{3}{8}$	$\frac{3}{8}$	$\frac{1}{2}$	$\frac{1}{2}$
Valve Stroke		mm	14	25	29	37	43	73	43
Displaced Bonnet Volume (Liters)			0.1	0.3	0.3	0.8	2.1	6.3	2.1
Approximate Shipping Weight (Kilograms)			18	29	45	79	181	295	227
FLOW CAPACITIES (L/S) GLOBE									
K_v (Globe)			13	19	26	47	110	190	120
Continuous (Globe)			13	19	29	50	114	196	145
Intermittent (Globe)			16	24	36	63	142	244	170
Momentary (Globe)			30	42	65	114	252	442	300
MAXIMUM PRESSURE RATINGS (DUCTILE ONLY)									
Bar ¹	Grooved Ends		27.6	27.6	27.6	27.6	27.6	27.6	27.6
MAXIMUM TEMPERATURE									
Celcius			82°	82°	82°	82°	82°	82°	82°

¹Valves rated and stamped 27.6 Bar as standard. Valves rated and stamped 41 Bar on request.

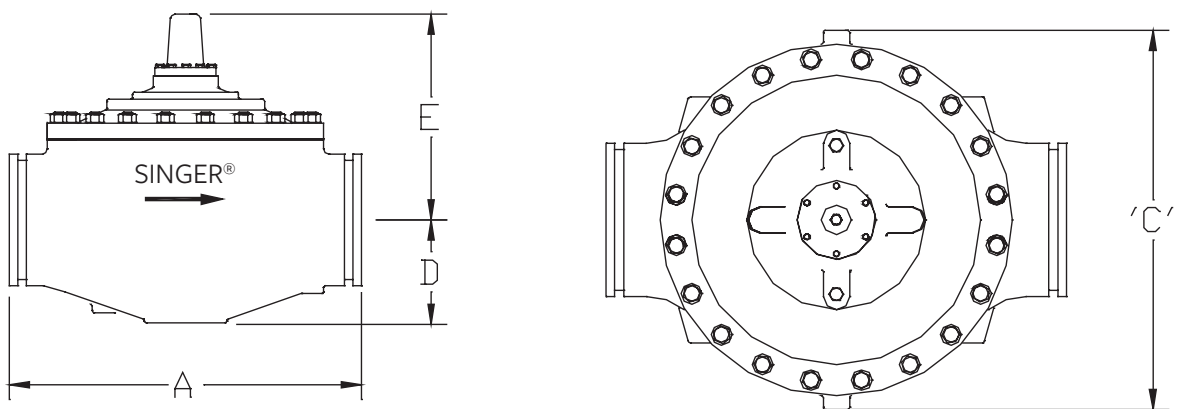

ORDERING INSTRUCTIONS

Refer to page 244 for the order form and ordering instructions.

MODEL 106-PG

Stainless Steel, Single Chamber, Hydraulically Operated Valve

KEY FEATURES

- Anti-cavitation option is ideal for high pressure drop situations
- Available in globe style

PRODUCT OVERVIEW

The 106-PG series control valve is designed to suit a large variety of applications such as pressure, flow or level control. This hydraulically operated valve introduces or releases water from the control chamber above the diaphragm to effectively maintain accurate water control.

Refer to Main Valve Options on page 62 and Pilots & Accessories on page 207 to further customize the valve to suit specific applications.

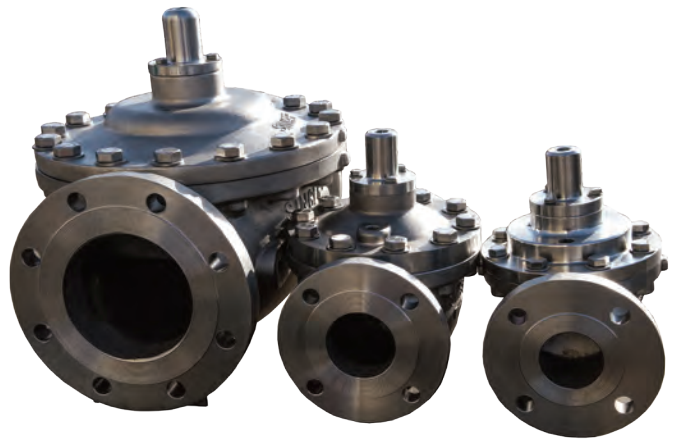

PRODUCT LINE DRAWING

ID	PART NAME
1	AISI 316 Stainless Steel Construction Valve Body, Cover
2	316 Stainless Steel Seat Ring
3	316 Stainless Steel Stem
4	316 Stainless Steel Spring
5	Diaphragm Buna-N or EPDM
6	Buna-N or EPDM Resilient Disc

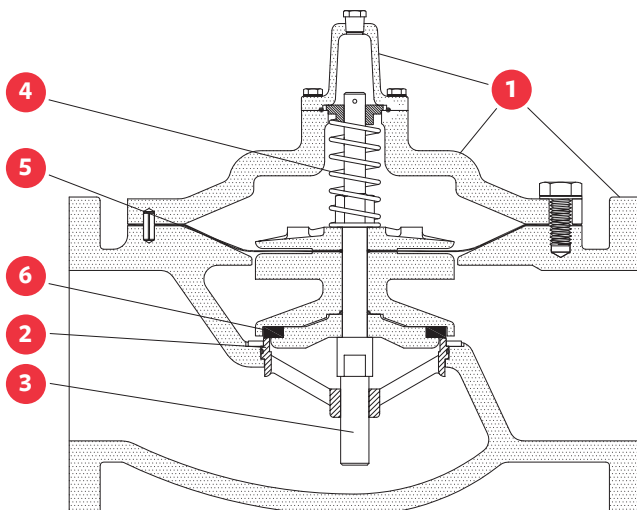

MODEL 106-PG

Stainless Steel, Single Chamber, Hydraulically Operated Valve

VALVE SIZES & MATERIALS

VALVE MATERIALS			
	Standard		Optional
Available Sizes	Threaded	Flanged	-
Globe	½" to 1 ½" (15-40 mm)	1 ½" to 6" (40 - 150 mm)	-
VALVE COMPONENTS			
1. Valve Body, Cover	316 Stainless Steel		-
2. Seat Ring	316 Stainless Steel		-
3. Disc Retainer	316 Stainless Steel		-
4. Stem	316 Stainless Steel		-
5. Stem Nut	316 Stainless Steel		-
6. Spring	316 Stainless Steel		-
7. Guide Bushings	316 Stainless Steel		-
8. Diaphragm	EPDM		Buna-N / Viton (limited sizes)
9. Resilient Disc	EPDM		Buna-N / Viton (limited sizes)
10. Fasteners	18-8 Stainless Steel		316 Stainless Steel

MODEL 106-PG

Stainless Steel, Single Chamber, Hydraulically Operated Valve

ANSI VALVE DATA (US UNITS)

SIZE	DWG	STANDARD	FLAT DIAPHRAGM SYSTEM										
			INCHES	REF	ANSI	1/2"	3/4"	1"	1 1/4"	1 1/2"	2"	2 1/2"	3"
GLOBE DIMENSIONS			ALL FIGURES SHOWN IN INCHES UNLESS OTHERWISE STATED										
Lay Length	A	FNPT	4.25	4.25	6.75	6.75	6.75	-	-	-	-	-	-
Centerline to Bottom	D	FNPT	0.83	0.83	2.50	2.50	2.50	-	-	-	-	-	-
Lay Length	A	150F	-	-	-	-	8.50	9.38	11.00	12.00	15.00	20.00	
Centerline to Bottom	D	150F	-	-	-	-	2.75	3.00	3.50	3.75	4.60	5.60	
Lay Length	A	300F	-	-	-	-	9.00	10.00	11.63	13.25	15.63	21.00	
Centerline to Bottom	D	300F	-	-	-	-	3.25	3.25	3.75	4.13	5.09	6.34	
COMMON DIMENSIONS (GLOBE & ANGLE)													
Width	C		3.00	3.00	4.88	4.88	6.13	6.50	8.19	9.25	10.88	16.75	
Height (To Stem Cap) Globe	E		3.06	3.06	4.38	4.38	4.38	4.75	7.50	8.00	9.15	11.75	
Height (To Stem Cap) Angle	E		-	-	4.38	4.38	4.38	4.75	7.50	8.00	9.15	11.75	
Body Port Tapping		FNPT	1/4	1/4	3/8	3/8	3/8	3/8	3/8	3/8	3/8	3/8	
Stem Cap Plug		MNPT	1/4	1/4	3/8	3/8	3/8	3/8	3/8	3/8	3/8	3/8	
Cover Port Tapping		FNPT	-	-	3/8	3/8	3/8	3/8	3/8	3/8	3/8	1/2	
Valve Stroke			1/4	1/4	1/2	1/2	1/2	9/16	1 1/16	1 1/8	1 7/16	1 11/16	
Displaced Bonnet Volume (Gallons)			0.002	0.002	0.007	0.007	0.007	0.018	0.066	0.090	0.20	0.56	
Approximate Shipping Weight (Lbs)			10	10	20	20	20	40	65	100	175	400	
CAPACITIES (USPGM) GLOBE & ANGLE													
C _v - Globe			6.4	6.4	28	30	32	55	80	110	200	460	
C _v - Angle			-	-	24	24	26	63	90	135	230	535	
Continuous (Globe)			12	19	49	93	125	210	300	460	800	1800	
Intermittent (Globe)			15	20	61	120	160	260	375	575	1000	2250	
Momentary (Globe)			28	43	110	170	250	470	670	1030	1800	4000	
MAXIMUM PRESSURE RATINGS (DUCTILE ONLY)													
psi ¹		FNPT	400	400	400	400	400	400	400	400	-	-	
psi		150F	-	-	-	-	250	250	250	250	250	250	
psi ¹		300F	-	-	-	-	400	400	400	400	400	400	
MAXIMUM TEMPERATURE													
Fahrenheit			180°	180°	180°	180°	180°	180°	180°	180°	180°	180°	

¹Valves rated and stamped 400 psi as standard. Valves rated and stamped 600 psi on request.

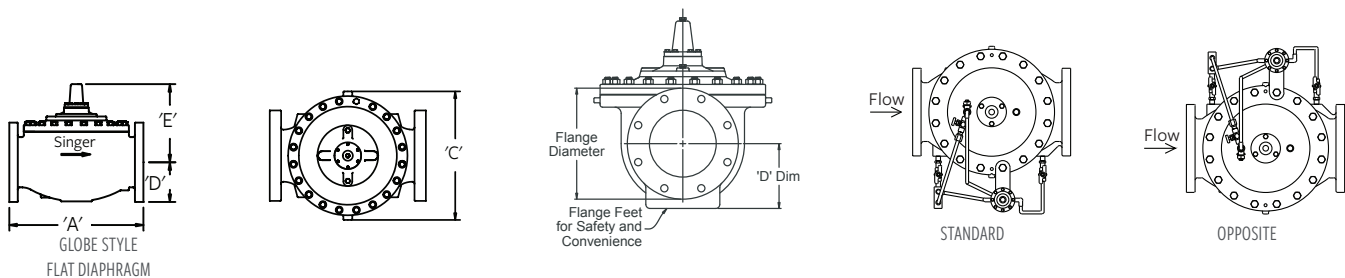

See pilot system information, page 207.

For additional Engineering notes, see page 242.

MODEL 106-PG

Stainless Steel, Single Chamber, Hydraulically Operated Valve

ANSI VALVE DATA (METRIC UNITS)

SIZE	DWG	STND	FLAT DIAPHRAGM SYSTEM										
			MM	REF	ANSI	15 MM	20 MM	25 MM	32 MM	40 MM	50 MM	65 MM	80 MM
GLOBE DIMENSIONS			ALL FIGURES SHOW IN MM UNLESS OTHERWISE STATED										
Lay Length	A	FNPT	108	108	171	171	171	-	-	-	-	-	-
Centerline to Bottom	D	FNPT	31	31	64	64	64	-	-	-	-	-	-
Lay Length	A	150F	-	-	-	-	216	238	279	305	381	508	
Centerline to Bottom	D	150F	-	-	-	-	70	76	89	95	117	142	
Lay Length	A	300F	-	-	-	-	229	254	295	337	397	533	
Centerline to Bottom	D	300F	-	-	-	-	83	83	95	105	129	161	
COMMON DIMENSIONS (GLOBE & ANGLE)													
Width	C		76	76	124	124	156	165	208	235	276	425	
Height (to stem cap) Globe	E		78	78	111	111	111	121	191	203	232	298	
Height (to stem cap) Angle	E		-	-	111	111	111	121	191	203	232	298	
Body Port Tapping	FNPT	Inches	¼	¼	⅜	⅜	⅜	⅜	⅜	⅜	⅜	⅜	
Stem Cap Plug	MNPT	Inches	¼	¼	⅜	⅜	⅜	⅜	⅜	⅜	⅜	⅜	
Cover Port Tapping	FNPT	Inches	-	-	⅜	⅜	⅜	⅜	⅜	⅜	⅜	½	
Valve Stroke		mm	6.4	6.4	13	13	13	14	25	29	37	43	
Displaced Bonnet Volume (Litres)			0.01	0.01	0.03	0.03	0.03	0.07	0.25	0.34	0.76	2.12	
Approximate Shipping Weight (Kilograms)			5.00	5.00	9.00	9.00	9.00	18.00	29.00	45.00	79.00	181.00	
CAPACITIES (L/S) GLOBE & ANGLE													
K _v - Globe (m ³ /h @ 1 bar)			5.5	5.5	24	26	28	48	69	95	173	398	
K _v - Angle (m ³ /h @ 1 bar)			-	-	21	21	22	54	78	117	199	463	
Continuous (Globe)			0.76	1.20	3.09	5.87	7.89	13.25	18.93	29.02	50.47	113.56	
Intermittent (Globe)			0.95	1.26	3.85	7.57	10.09	16.40	23.66	36.28	63.09	141.95	
Momentary (Globe)			1.77	2.71	6.94	10.73	15.77	29.65	42.27	64.98	113.56	252.36	
MAXIMUM PRESSURE RATINGS (DUCTILE ONLY)													
Bar ¹	FNPT		27.6	27.6	27.6	27.6	27.6	27.6	27.6	27.6	-	-	
Bar	150F		-	-	-	-	17	17	17	17	17	17	
Bar ¹	300F		-	-	-	-	27.6	27.6	27.6	27.6	27.6	27.6	
MAXIMUM TEMPERATURE													
Celcius			82°	82°	82°	82°	82°	82°	82°	82°	82°	82°	

¹Valves rated and stamped 27.6 bar as standard. Valves rated and stamped 41 bar on request.

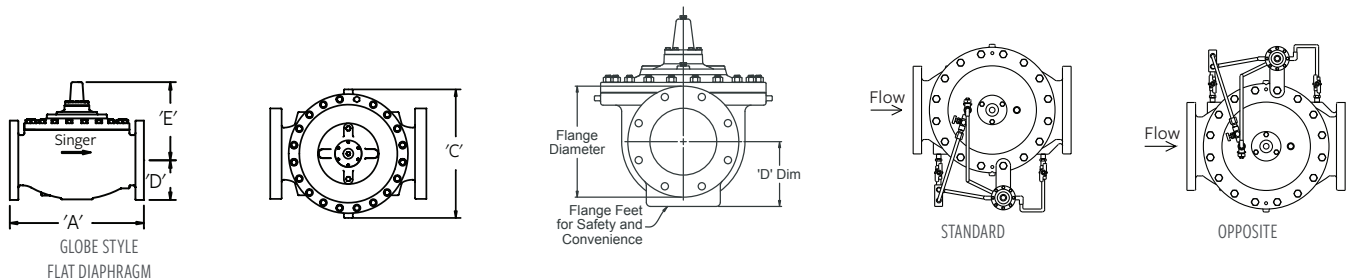

See pilot system information, page 207.

For additional Engineering notes, see page 242.

MODEL 106-PG

Stainless Steel, Single Chamber, Hydraulically Operated Valve

ISO VALVE DATA (METRIC UNITS)

SIZE	DWG	STND	FLAT DIAPHRAGM SYSTEM											
			MM	REF	ISO	15 MM	20 MM	25 MM	32 MM	40 MM	50 MM	65 MM	80 MM	100 MM
GLOBE DIMENSIONS			ALL FIGURES SHOW IN MM UNLESS OTHERWISE STATED											
Lay Length	A	BSPT	108	108	171	171	171	-	-	-	-	-	-	-
Centerline to Bottom	D	BSPT	31	31	64	64	64	-	-	-	-	-	-	-
Lay Length	A	PN10 / PN16	-	-	-	-	229	238	279	318	381	508	-	-
Centerline to Bottom	D	PN10 / PN16	-	-	-	-	83	76	89	100	117	142	-	-
Lay Length	A	PN25 / PN40	-	-	-	-	229	238	279	318	397	533	-	-
Centerline to Bottom	D	PN25 / PN40	-	-	-	-	83	76	89	100	129	161	-	-
COMMON DIMENSIONS (GLOBE & ANGLE)														
Width	C		76	76	124	124	156	152	208	235	276	425	-	-
Height (To Stem Cap) Globe	E		78	78	111	111	111	121	191	203	232	298	-	-
Height (To Stem Cap) Angle	E		-	-	111	111	111	121	191	203	232	298	-	-
Body Port Tapping	FNPT	Inches	¼	¼	⅜	⅜	⅜	⅜	⅜	⅜	⅜	⅜	⅜	⅜
Stem Cap Plug	MNPT	Inches	¼	¼	⅜	⅜	⅜	⅜	⅜	⅜	⅜	⅜	⅜	⅜
Cover Port Tapping	FNPT	Inches	-	-	⅜	⅜	⅜	⅜	⅜	⅜	⅜	⅜	½	-
Valve Stroke		mm	6.4	6.4	13	13	13	14	25	29	37	43	-	-
Displaced Bonnet Volume (Litres)			0.01	0.01	0.03	0.03	0.03	0.07	0.25	0.34	0.76	2.12	-	-
Approximate Shipping Weight (Kilograms)			5	5	9	9	9	18	29	45	79	181	-	-
CAPACITIES (L/S) GLOBE & ANGLE														
K _v - Globe (m ³ /h @ 1 bar)			5.5	5.5	24	26	28	48	69	95	173	398	-	-
K _v - Angle (m ³ /h @ 1 bar)			-	-	21	21	22	54	78	117	199	463	-	-
Continuous (Globe)			0.76	1.20	3.09	5.87	7.89	13.25	18.93	29.02	50.47	113.56	-	-
Intermittent (Globe)			0.95	1.26	3.85	7.57	10.09	16.40	23.66	36.28	63.09	141.95	-	-
Momentary (Globe)			1.77	2.71	6.94	10.73	15.77	29.65	42.27	64.98	113.56	252.36	-	-
MAXIMUM PRESSURE RATINGS (DUCTILE ONLY)														
Bar ¹		BSPT	27.6	27.6	27.6	27.6	27.6	27.6	27.6	27.6	27.6	-	-	-
Bar		PN16	-	-	-	-	16	16	16	16	16	16	16	16
Bar ¹		PN25	-	-	-	-	25	25	25	25	25	25	25	25
MAXIMUM TEMPERATURE														
Celcius			82°	82°	82°	82°	82°	82°	82°	82°	82°	82°	82°	82°

¹Valves rated and stamped 27.6 bar as standard. Valves rated and stamped 41 bar on request.

MODEL 106-IDC / 206-IDC

Internal Drop Check

KEY FEATURES

- Prevents reverse flow and reduces surges
- Completely mechanical and has no dependency on the pilot system
- Silent operation

PRODUCT OVERVIEW

The Internal Drop Check (IDC) ensures quick positive shut-off whenever normal forward flow stops, this action will prevent reverse flow while reducing surge events.

The IDC assembly is a spring assisted, silent, mechanical check option for standard Singer® main valves and comes in sizes ranging from 2" / 50 mm – 36" / 900 mm.

The IDC is a standard feature on the 106-PTC and 206-PTC series control valves and is available as an optional add-on for control valves larger than 2" / 50 mm.

STANDARD MATERIAL

- Inner Valve: ASTM A536 Ductile Iron
- Inner Valve Sleeve: B-62 Bronze or AISI 316 Stainless Steel
- Stem: AISI 316 Stainless Steel
- O-Ring Seals: Buna-N
- Spring is optional on 106 series valves larger than 10" / 250 mm and 206 series valves larger than 12" / 300 mm.
(On all other sizes, the spring is included.)

ORDERING INSTRUCTIONS

Refer to page 244 for the order form and ordering instructions.

Note:

- PTC valves include the IDC
- This IDC may be included as standard with some products

PRODUCT LINE DRAWING

ID	PART NAME
1	IDC - Internal Drop Check
2	IDC Stem
3	Spring (optional) in sizes 10" / 250 mm and larger 106
4	Inner Valve
5	Disc Retainer
6	Inner Valve Sleeve



Valve Fully Closed:
Pressure Above Diaphragm
Drives Diaphragm Assembly and IDC
Down to Seal the Valve.

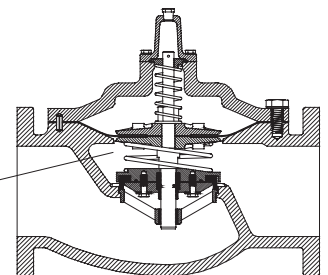

Main Valve Fully Open:
Diaphragm and Inner Valve
Assembly Controlled by the
Pilot System.

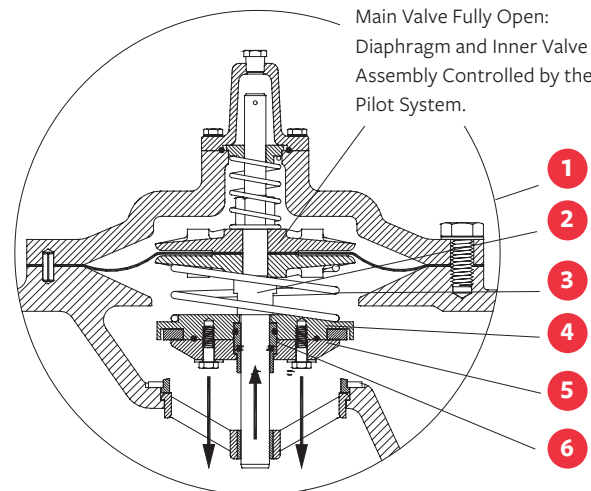

Should Forward Flow Stop for any Reason, the IDC Moves Down to Seal Against Reverse Flow, Regardless of the Valve Position.

106-NYM / 206-NYM

Internal Drop Check No Yellow Metal

NO YELLOW METAL UPGRADE OPTION

Yellow metal components such as Brass, Bronze and Copper may not be acceptable materials in harsh water conditions or in specific specifications for a variety of reasons. All or any portion of yellow metals in the internals of main valves may be upgraded to stainless steel. All or any portion of yellow metals on pilots or pilot tubing and fittings may also be upgraded to stainless steel.

ORDERING INSTRUCTIONS

Refer to page 244 for the order form and ordering instructions.

Note: The -NYM option may be included as standard with some products.

Include -NYM addendum to main valve order.

MODELS 106-RW / 206-RW

Reclaimed Water Valve

KEY FEATURES

- Resists corrosion from chlorine chloramine and other corrosive elements typically found in grey or reclaimed water
- Can be used in all standard and special applications

PRODUCT OVERVIEW

The 106-RW and 206-RW series control valves offer superior corrosion resistance performance in grey or reclaimed water applications and can be used in all standard and special applications.

It's constructed from materials which are selected specifically to address corrosion concerns from chlorine, chloramine, and other corrosive elements typically found in grey or reclaimed water.



MODELS X107 POSITION INDICATOR

KEY FEATURES

- Manually purge trapped air through the pet cock
- Simple and safe retrofit installation through the main valve stem cap
- Stainless steel indicator rod and pin for longevity

PRODUCT OVERVIEW

The X107 position indicator stem is designed to provide direct indication of the diaphragm / inner valve position. The indicator stem moves up and down within its protective hexagonal brass housing. Within the housing is clear Pyrex sight glass, which allows viewing from both sides.

Our main control valves are designed with a separate stem cap that makes installation of the X107 safe and simple to do in the field.



MODELS X107

Position Indicator

PRODUCT LINE DRAWING

ID	PART NAME
1	Cap and Bleed Valve (SST)
2	O-Ring Seal (Buna-N)
3	Buna/EPDM
4	Open Notch Sight
5	Tube (Pyrex)
6	Closed Notch
7	Indicator Body (Brass)
8	Main Valve Stem Cap (Ductile Iron)
9	Indicator Pin and Retaining Pin (Stainless Steel)

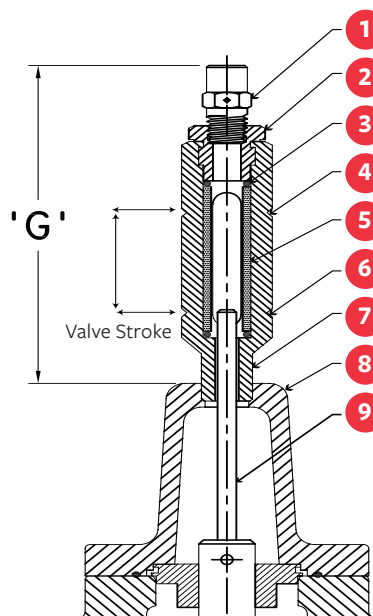

STANDARD MATERIALS

- Body: Brass
- Bleed Valve: SST
- Indicator Rod: SST
- O-ring Seals: Buna-N
- Indicator Body: Brass
- Sight Tube: PYREX
- Indicator Pin: SST

ORDERING INSTRUCTIONS

Refer to page 244 for the order form and ordering instructions.

Note: this X107 may be included as standard with some products

SIZES & HEIGHTS

106-X107

DIMENSION 'G' HEIGHT

Sizes (in)	1"	1 ¼"	1 ½"	2"	2 ½"	3"	4"	6"	8"	10"	12"	14"	16"	20"	24"	36"
Sizes (mm)	25 mm	32 mm	40 mm	50 mm	65 mm	80 mm	100 mm	150 mm	200 mm	250 mm	300 mm	350 mm	400 mm	500 mm	600 mm	900 mm
Height (in)	3.5"	3.5"	3.5"	3.5"	4.75"	4.75"	4.75"	4.75"	6"	6.88"	6.88"	6.88"	7.75"	9.5"	9.5"	12.75"
Height (mm)	89 mm	89 mm	89 mm	89 mm	121 mm	121 mm	121 mm	121 mm	153 mm	175 mm	175 mm	175 mm	197 mm	241 mm	241 mm	324 mm

206-X107

DIMENSION 'G' HEIGHT

Sizes (in)	3"	4"	6"	8"	10"	12"	16"	18"	20"	24"	28"	30"	32"	36"	40"	48"
Sizes (mm)	80 mm	100 mm	150 mm	200 mm	250 mm	300 mm	400 mm	450 mm	500 mm	600 mm	700 mm	750 mm	800 mm	900 mm	1000 mm	1200 mm
Height (in)	4.75"	4.75"	4.75"	4.75"	6"	6.88"	6.88"	7.75"	7.75"	9.5"	9.5"	9.5"	9.5"	9.5"	12.75"	12.75"
Height (mm)	121 mm	121 mm	121 mm	121 mm	153 mm	175 mm	175 mm	197 mm	197 mm	241 mm	241 mm	241 mm	241 mm	241 mm	324 mm	324 mm

CF = Consult Factory

MODEL X156

Linear Inductive Valve Position Transmitter

KEY FEATURES

- The stainless steel actuator stem is pinned directly to the main valve stem
- Stems on main valves larger than 2 1/2" / 65 mm are pre-drilled for easy installation
- Separate stem cap permits easy field installation
- Combination water-tight rated enclosure to NEMA 4X and NEMA 6

PRODUCT OVERVIEW

The X156 Linear Inductive Valve Position Transmitter electronically indicates the position of the valve and is ideal for applications where precision and accuracy is required. It is mounted directly to the main valve stem and uses an external source of 24 VDC power, a 4 to 20 mA signal proportional to valve stroke is generated and transmitted. The zero and span are fully adjustable over the complete range of stroke.

STANDARD MATERIAL

- Adapter: ASTM B-16
- Target: AISI 416 stainless steel
- Actuator Stem: AISI 316 stainless steel
- O-Ring Seals: Buna-N
- Seal Bushing: ASTM B-16 brass
- Mounting Plate: Coated steel
- Actuator Stem Pin: 18-8 stainless steel

SIZES & HEIGHTS

Dimension G in the above image is the height added to the valve by the assembly.



ORDERING INSTRUCTIONS

- Available without 4-20 mA rescaler
- Available with optional external limit switches

Refer to page 244 for the order form and ordering instructions.

Additionally, include the following information for this product:

- Integrated discrete switch output (optional)

106-X156

DIMENSION 'G' HEIGHT

Sizes (in)	2 1/2"	3"	4"	6"	8"	10"	12"	14"	16"	20"	24"	36"
Sizes (mm)	65 mm	80 mm	100 mm	150 mm	200 mm	250 mm	300 mm	350 mm	400 mm	500 mm	600 mm	1000 mm
Height (in)	7"	7"	7.38"	9"	9"	9"	9"	9"	9"	12.5"	12.5"	31"
Height (mm)	230 mm	230 mm	230 mm	230 mm	230 mm	230 mm	230 mm	230 mm	230 mm	318 mm	318 mm	788 mm

206-X156

DIMENSION 'G' HEIGHT

Sizes (in)	3"	4"	6"	8"	10"	12"	16"	18"	20"	24"	28"	30"	32"	36"	40"	48"
Sizes (mm)	80 mm	100 mm	150 mm	200 mm	250 mm	300 mm	400 mm	450 mm	500 mm	600 mm	700 mm	750 mm	800 mm	900 mm	1000 mm	1200 mm
Height (in)	9"	9"	9"	9"	9"	9"	9"	9"	9"	9"	12.5"	12.5"	12.5"	12.5"	31"	31"
Height (mm)	230 mm	230 mm	230 mm	230 mm	230 mm	230 mm	230 mm	230 mm	230 mm	230 mm	318 mm	318 mm	318 mm	318 mm	788 mm	788 mm

MODEL OXY

Nitride Stem

PRODUCT OVERVIEW

The Oxy-Nitride stem is ideally suited to reclaimed water applications and a wide range of other applications where mineral-build up is a concern.

When minerals build-up on stems, it can cause potential maintenance problems and operational malfunctions. The Oxy-Nitride treated stainless steel stem is the perfect solution. Its specialized proprietary aerated salt bath treatment will reduce or prevent mineral build-up allowing the stem to stroke freely as it passes through the guide bushing. The Oxy-Nitride stem also increases surface hardness for wear, fatigue and lubricity.

ORDERING INSTRUCTIONS

Refer to page 244 for the order form and ordering instructions.

Note: this Oxy-Nitride Stem may be included as standard with some products



MODEL X129

Limit Switch Indicator

KEY FEATURES

- All main valve stems are pre-drilled ready to accept this option
- The Single Pole Double Throw limit switch is rated up to 10 A, 250 V, NEMA 4 enclosure with UL and CSA listings.
- Maximum Working Pressure: 400 psi / 27.6 bar

PRODUCT OVERVIEW

The X129 limit switch is actuated by the opening and closing of a main valve. The assembly is fully adjustable over the entire valve stroke. Layout variations allow up to four separate switches to be mounted and actuated off the same stem.

STANDARD MATERIALS

- Adapter: Brass
- Stem Hat: Brass
- Actuator Stem: SST
- O-ring Seals: Buna-N
- Seal Bushing: Brass
- Mounting Plate: Brass
- Actuator Pin: SST

OPTIONAL

- Stainless Steel
- Double Pole Double Throw (DPDT)
- Up to 4 Switches
- Explosion proof housing
- Nema 6/6P rating

PRODUCT LINE DRAWING

ID	PART NAME
1	Stem Hat
2	Adapter and Seal Bushing Bleed Screw (vent air)
3	Limit Switch
4	Limit Switch Mounting Assembly
5	Actuator Stem and Retaining Pin
6	Main Valve Stem Cap (separate and removable)

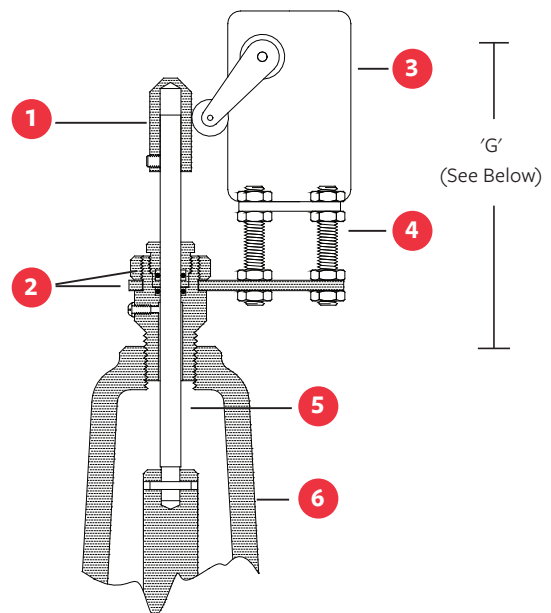
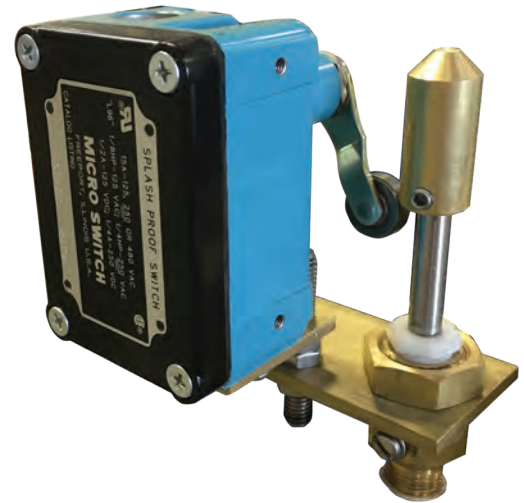

MODEL X129 LIMIT SWITCH ASSEMBLY

MODEL X129

Limit Switch Indicator

SIZES & HEIGHTS

Dimension G is the height added to the valve by the assembly.

106-X129

DIMENSION 'G' HEIGHT

Sizes (inches)	2"	2 ½"	3"	4"	6"	8"	10"	12"	14"	16"	20"	24"	36"
Sizes (mm)	50 mm	65 mm	80 mm	100 mm	150 mm	200 mm	250 mm	300 mm	350 mm	400 mm	500 mm	600 mm	900 mm
Height (inches)	7	7	7	7.38	7.75	8.75	9.63	9.63	9.63	11.06	12.25	12.25	15.25
Height (mm)	178	178	178	187	197	222	245	245	245	281	311	311	387

206-X129

DIMENSION 'G' HEIGHT

Sizes (inches)	3"	4"	6"	8"	10"	12"	16"	18"	20"	24"	28"	30"	32"	36"	40"	48"
Sizes (mm)	80 mm	100 mm	150 mm	200 mm	250 mm	300 mm	400 mm	450 mm	500 mm	600 mm	700 mm	750 mm	800 mm	900 mm	1000 mm	1200 mm
Height (inches)	7	7	7.38	7.75	8.75	9.63	9.63	11.06	11.06	11.06	12.25	12.25	12.25	12.25	15.25	15.25
Height (mm)	178	178	187	197	222	245	245	281	281	281	311	311	311	311	387	387

ORDERING INSTRUCTIONS

Refer to page 244 for the order form and ordering instructions.

Additionally, include the following information for this product:

- Quantity of Limit Switches
- Actuation positions
- SPDT or DPDT contacts
- Optional explosion proof housing

Note:

- For retrofit, please include serial number
- This may be included as standard with some products

MODEL 106-AC

Anti-Cavitation Control Valve

KEY FEATURES

- Solves cavitation problems
- Controls variable flows and vibration
- Reduces noise significantly
- Every valve optimized for actual operating conditions

PRODUCT OVERVIEW

The 106-AC series control valve solves cavitation problems by taking the pressure drop in two stages and at higher pressure drops allowing and containing cavitation inside the Recovery Chamber. Reduced velocity out of the Recovery Chamber prevents cavitation and reduces noise and vibration.

PRODUCT LINE DRAWING

ID	PART NAME
1	Removable Stem Cap
2	ASTM A536 Ductile Iron Construction
3	316 Stainless Steel Stem
4	Buna-N / EPDM Diaphragm
5	Buna-N / EPDM Resilient Disc
6	316 Stainless Steel Seat
7	Cavitation Recovery Chamber - AISI 316
8	NSF 61 Fusion Bonded Epoxy Coating

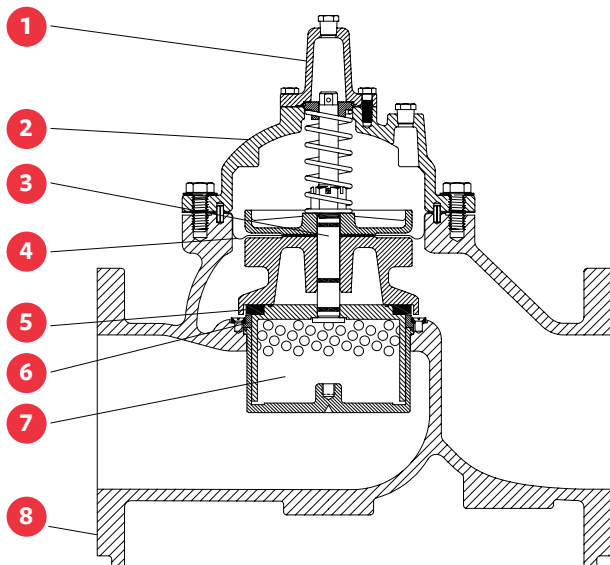

MODEL 106-AC

Anti-Cavitation Control Valve

TYPICAL APPLICATION PRESSURE REDUCING

Your application has a maximum continuous design flow of 1200 USGPM (76 l/s) and a minimum of 100 USGPM (6.3 l/s). Inlet pressure ranges from 200 psi (13.8 bar) at maximum flow to 250 psi (17.2 bar) at minimum flow. You need a relatively constant outlet pressure of 30 psi (2 bar). There is a possibility of demand for 2000 USGPM (130 l/s).

SELECTION

Pressure Reducing: 6" / 150 mm Singer® model 106-PR-AC, ANSI Class 150 flange, range 10 – 80 psi / 0.7 bar – 5.5 bar, set at 30 psi / 2 bar

SELECTION AND SIZING

1. Referring to page 240 Cavitation Chart, 250 psi (17.2 bar) to 30 psi (2 bar) is deep in the severe cavitation zone. Anti-Cavitation valve is required.
2. There seems to be no reason for the downstream pressure to go sub-atmospheric. Application is OK.
3. 200 psi (13.8 bar) is 80% of 250 psi (17.2 bar). Application is OK.
4. 220 psi (15 bar) pressure drop is acceptable for an outlet pressure of 30 psi (2 bar).

5. Referring to Graph 106-415 on page 82 or 239, intersection of minimum pressure drop of 170 psi (11.7 bar) and maximum flow of 1200 GPM (76 l/s) is right on the line for 4" (100 mm) valve. If a capacity of 2000 GPM (130 l/s) is required, a 6" valve would be selected.
6. Referring to pages 14 to 19, maximum recommended continuous flow for a 4" 106 valve is 800 GPM (50 l/s). If it is expected that flows of more than 800 GPM (50 l/s) will take place more than intermittently, a 6" valve should be selected. Referring to page 100, 100 GPM (6.3 l/s) is higher than minimum recommended flow for 4" (100mm) or 6" (150mm) pressure reducing valve.

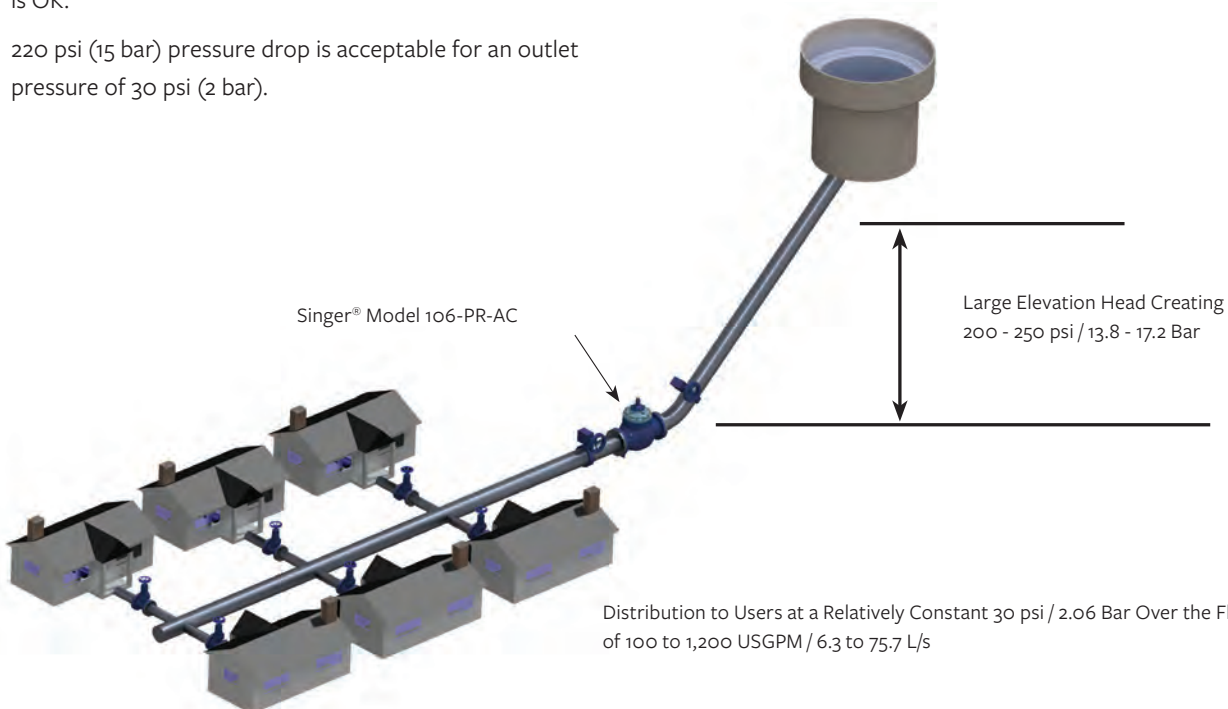

MODEL 106-AC

Anti-Cavitation Control Valve

TYPICAL APPLICATION CONTINUOUS SUSTAINING

Your application requires the discharge pressure of a fixed speed pump to be limited to a pressure that keeps the pressure in an old distribution zone to a maximum of 110 psi (7.6 bar). The pump is designed for 1200 USGPM (76 l/s) at 140 psi (9.6 bar) Shut-off head is 450' (137 m) or 195 psi (13.5 bar). The zone is 55' (34m) above the pump outlet.

SELECTION AND SIZING

To keep the pressure in the distribution zone to a maximum of 110 psi (7.6 bar), we must limit the pressure on the pump discharge header to 110 psi (7.6 bar) + 50' (34 m) or 132 psi (9.1 bar).

1. Referring to Cavitation Chart on page 240, 132 psi (9.1 bar) is in the very severe cavitation zone. Anti-Cavitation valve is a must.
2. It is likely that sub-atmospheric pressure will develop on the outlet of the valve. A vacuum breaker is required.
3. Pressure drop is constant. Application is OK.
4. 132 psi (9.1 bar) to atmosphere is OK.
5. Referring to Graph 106-415 on page 82 or 239, intersection of 132 psi (9.1 bar) and 1200 GPM (76 l/s) is above the line for 4" (100 mm) valve but below the line for 6" (150 mm) line. Select a 6" (150 mm) valve.
6. Referring to pages 11 to 19, recommended continuous flow for 6" (150 mm) valve is 1800 GPM (114 l/s). 6" (150 mm) valve is OK. Referring to page 120, minimum recommended flow for 6" (150mm) 106-RPS pressure sustaining valve is 20 USGPM (1.3 l/s) for flat diaphragm valve and 1 USGPM (0.06 l/s) for rolling diaphragm valve. Low flow should not be a problem.

Old Distribution Zone to Users:
Maximum 110 psi / 7.6 Bar

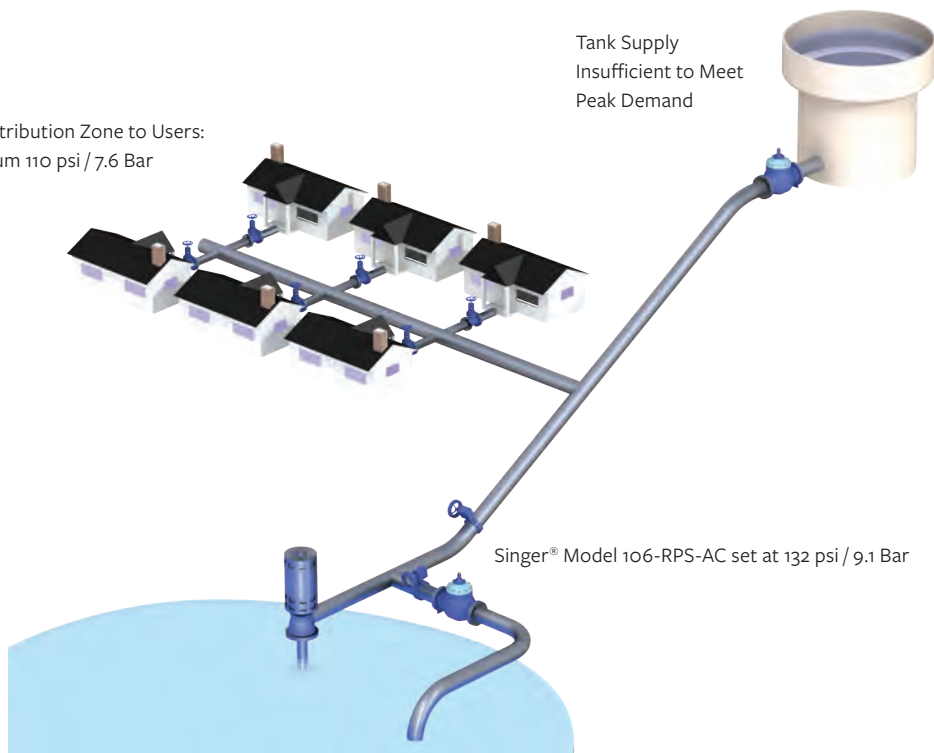

MODEL 106-AC

Anti-Cavitation Control Valve

106-AC VALVE SIZES AND MATERIALS

VALVE MATERIALS

	Standard		Optional
	Threaded	Flanged	
Available Sizes			-
Globe	1" to 3" (25 - 80 mm)	1 ½" to 36" (40 - 900 mm)	-

VALVE COMPONENTS

1. Valve Body, Cover	65-45-12 Ductile Iron	316 Stainless Steel (limited sizes)
2. Seat Ring	316 Stainless Steel	-
4. Stem	316 Stainless Steel	-
5. Stem Nut	B16 Brass	316 Stainless Steel
6. Spring	316 Stainless Steel	-
7. Guide Bushings	B16 Brass or SAE 660 Bronze	AISI 316 Stainless Steel
8. Diaphragm	EPDM	Buna-N / Viton (limited sizes)
9. Resilient Disc	EPDM	Buna-N / Viton (limited sizes)
10. Coating	NSF61 Approved Fusion Bonded Epoxy - Thickness 10-14 mils (250-350 microns)	Consult factory
11. Fasteners	18-8 Stainless Steel	316 Stainless Steel
12. Anti-Cavitation Cage	316 Stainless Steel	-

SELECTION AND SIZING

- Check Cavitation Chart on page 240. If the intersection of inlet pressure and outlet pressure is inside the cavitation zone, Anti-Cavitation valve is recommended. As a guide, if the pressure drop is more than $\frac{2}{3}$ of the inlet pressure, cavitation may occur.
- If there is any possibility that the outlet pressure can be sub-atmospheric even occasionally, consult with us or one of our representatives for a possible solution.
- If the pressure drop varies more than 25%, consult with us or one of our representatives for a solution.
- If the outlet pressure is less than 20 psi (1.38 bar), pressure drop should be limited to 200 psi (13.8 bar) for continuous service.
- Refer to Graph 106-415 on pages 82 or 239. Locate intersection of minimum pressure

drop on the horizontal axis and maximum flow on the vertical axis. Select the next valve size above this intersection.

- Refer to pages 14 to 19 for recommended limitations for Continuous and Intermittent flows and description of standard valve for minimum stable flow where applicable.

ORDERING INSTRUCTIONS

Refer to page 244 for the order form and ordering instructions.

Additionally, include the following information for this product:

- Inlet / outlet pressure range
- Minimum / maximum differential pressure
- Minimum / maximum flow rate

MODEL 106-AC

Anti-Cavitation Control Valve

VALVE DATA (US UNITS)

SIZE	DWG	STANDARD	FLAT DIAPHRAGM SYSTEM								
INCHES	REF	ANSI	1"	1 1/4"	1 1/2"	2"	2 1/2"	3"	4"	6"	8"
GLOBE DIMENSIONS			ALL FIGURES SHOWN IN INCHES UNLESS OTHERWISE STATED								
Lay Length	A	FNPT	6.75	6.75	6.75	9.38	11.00	13.50	-	-	-
Centerline to Bottom	D	FNPT	2.50	2.50	2.50	2.75	3.38	3.68	-	-	-
Lay Length	A	150F	-	-	8.50	9.38	11.00	12.00	15.00	20.00	25.38
Centerline to Bottom	D	150F	-	-	2.75	3.00	3.50	3.75	4.60	5.60	7.88
Lay Length	A	300F	-	-	9.00	10.00	11.63	13.25	15.63	21.00	26.38
Centerline to Bottom	D	300F	-	-	3.25	3.25	3.75	4.13	5.09	6.34	7.88
COMMON DIMENSIONS (GLOBE)											
Width	C		4.88	4.88	6.13	6.50	8.19	9.25	10.88	16.75	21.63
Height (To Stem Cap) Globe	E		4.38	4.38	4.38	4.75	7.50	8.00	9.15	11.75	14.91
Body Port Tapping		FNPT	3/8	3/8	3/8	3/8	3/8	3/8	3/8	3/8	1/2
Stem Cap Plug		MNPT	3/8	3/8	3/8	3/8	3/8	3/8	3/8	3/8	3/8
Cover Port Tapping		FNPT	3/8	3/8	3/8	3/8	3/8	3/8	3/8	1/2	1/2
Valve Stroke			9/16	9/16	9/16	9/16	15/16	1 1/8	1 7/16	1 11/16	2 7/8
Displaced Bonnet Volume (Gallons)			0.007	0.007	0.007	0.02	0.07	0.09	0.20	0.56	1.67
Approximate Shipping Weight (Lbs)			25	25	25	45	80	125	250	400	700
Capacities			Please consult with us								
MAXIMUM PRESSURE RATINGS (DUCTILE ONLY)											
psi ¹		FNPT	400	400	400	400	400	400	-	-	-
psi		150F	-	-	-	250	250	250	250	250	250
psi ¹		300F	-	-	-	400	400	400	400	400	400
MAXIMUM TEMPERATURE											
Fahrenheit			180°	180°	180°	180°	180°	180°	180°	180°	180°

¹Valves rated and stamped 400 psi as standard. Valves rated and stamped 600 psi on request.

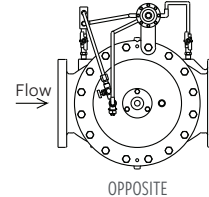
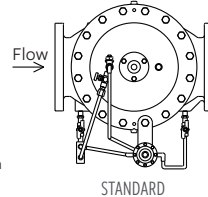
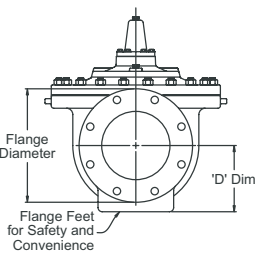
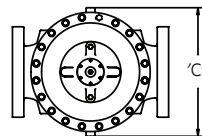
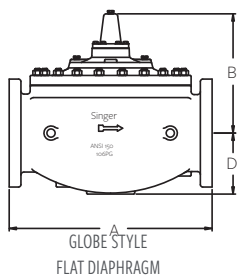

See pilot system information, page 207.
For additional Engineering notes, see page 242.

MODEL 106-AC

Anti-Cavitation Control Valve

VALVE DATA (US UNITS)

SIZE	DWG	STANDARD	ROLLING DIAPHRAGM SYSTEM								
			INCHES	REF	ANSI	6"	8"	10"	12"	16"	20"
GLOBE DIMENSIONS			ALL FIGURES SHOWN IN INCHES UNLESS OTHERWISE STATED								
Lay Length	A	FNPT	-	-	-	-	-	-	-	-	-
Centerline to Bottom	D	FNPT	-	-	-	-	-	-	-	-	-
Lay Length	A	150F	20.00	25.38	29.75	34.00	41.38	52.00	61.50	76.00	
Centerline to Bottom	D	150F	5.60	7.63	8.25	9.62	12.13	14.43	17.13	23.50	
Lay Length	A	300F	21.00	26.38	31.13	35.50	43.50	53.62	63.25	78.00	
Centerline to Bottom	D	300F	6.34	7.88	9.00	10.38	13.13	15.75	19.65	25.50	
COMMON DIMENSIONS (GLOBE & ANGLE)											
Width	C		12.75	16.09	18.00	21.25	27.06	35.00	49.68	64.50	
Height (To Stem Cap) Globe	E		15.43	20.19	22.13	23.75	30.31	35.50	45.75	61.00	
Body Port Tapping		FNPT	$\frac{3}{8}$	$\frac{1}{2}$	$\frac{3}{4}$	$\frac{3}{4}$	$\frac{3}{4}$	$\frac{3}{4}$	$\frac{3}{4}$	1	
Stem Cap Plug		MNPT	$\frac{3}{8}$	$\frac{3}{8}$	$\frac{3}{4}$	$\frac{3}{4}$	$\frac{3}{4}$	$\frac{3}{4}$	$\frac{3}{4}$	1	
Cover Port Tapping		FNPT	$\frac{1}{2}$	$\frac{1}{2}$	$\frac{3}{4}$	$\frac{3}{4}$	$\frac{3}{4}$	$\frac{3}{4}$	$\frac{3}{4}$	1	
Valve Stroke			$1 \frac{11}{16}$	$2 \frac{7}{8}$	$3 \frac{1}{4}$	$3 \frac{3}{4}$	$4 \frac{3}{4}$	$5 \frac{1}{16}$	6	9	
Displaced Bonnet Volume (Gallons)			0.5	1.0	1.5	2.3	6.8	9.0	14.8	43.0	
Approximate Shipping Weight (Lbs)			360	660	900	1400	2400	3450	5300	13500	
Flow Capacities			Please consult with us								
MAXIMUM PRESSURE RATINGS (DUCTILE ONLY)											
psi ¹		FNPT	-	-	-	-	-	-	-	-	
psi		150F	250	250	250	250	250	250	250	250	
psi ¹		300F	400	400	400	400	400	400	400	400	
MAXIMUM TEMPERATURE											
Fahrenheit			180°	180°	180°	180°	180°	180°	180°	180°	

¹Valves rated and stamped 400 psi as standard. Valves rated and stamped 600 psi on request.

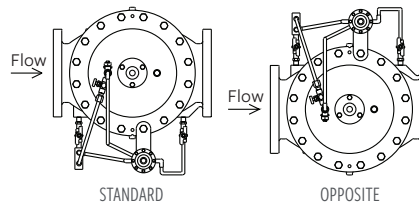
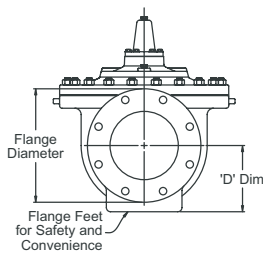
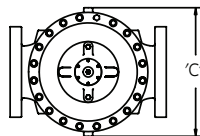
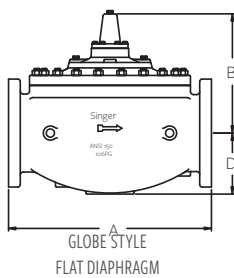

See pilot system information, page 207.
For additional Engineering notes, see page 242.

MODEL 106-AC

Anti-Cavitation Control Valve

AC VALVE DATA (ISO UNITS)

SIZE	DWG	STANDARD	FLAT DIAPHRAGM SYSTEM									
			MM	REF	ISO	25 MM	32 MM	40 MM	50 MM	65 MM	80 MM	100 MM
GLOBE DIMENSIONS			ALL FIGURES SHOWN IN MM UNLESS OTHERWISE STATED									
Lay Length	A	BSPT	171	171	171	238	279	343	-	-	-	-
Centerline to Bottom	D	BSPT	64	64	64	70	86	93	-	-	-	-
Lay Length	A	PN10 / PN16	-	-	229	238	279	318	381	508	645	-
Centerline to Bottom	D	PN10 / PN16	-	-	83	76	89	100	117	142	200	-
Lay Length	A	PN25 / PN40	-	-	229	238	295	318	397	533	670	-
Centerline to Bottom	D	PN25 / PN40	-	-	83	76	89	100	129	161	200	-
COMMON DIMENSIONS (GLOBE)												
Width	C		124	124	156	152	208	235	276	425	549	-
Height (To Stem Cap) Globe	E		111	111	111	121	191	203	232	298	379	-
Body Port Tapping	FNPT	Inches	3/8	3/8	3/8	3/8	3/8	3/8	3/8	3/8	3/8	1/2
Stem Cap Plug	MNPT	Inches	3/8	3/8	3/8	3/8	3/8	3/8	3/8	3/8	3/8	3/8
Cover Port Tapping	FNPT	Inches	3/8	3/8	3/8	3/8	3/8	3/8	3/8	1/2	1/2	-
Valve Stroke		mm	14	14	14	14	25	29	37	43	73	-
Displaced Bonnet Volume (Liters)			0.03	0.03	0.03	0.1	0.3	0.3	0.8	2.1	6.3	-
Approximate Shipping Weight (Kilograms)			11	11	11	20	36	57	113	181	317	-
Capacities	Please consult with us											
MAXIMUM PRESSURE RATINGS (DUCTILE ONLY)												
Bar	BSPT		27.6	27.6	27.6	27.6	27.6	27.6	-	-	-	-
Bar	PN16		-	-	-	16	16	16	16	16	16	16
Bar	PN25		-	-	-	25	25	25	25	25	25	25
MAXIMUM TEMPERATURE												
Celcius			82°	82°	82°	82°	82°	82°	82°	82°	82°	82°

*Valves rated and stamped 27.6 bar as standard. Valves rated and stamped 41 bar on request.

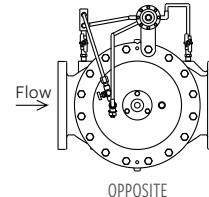
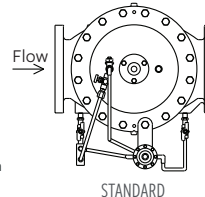
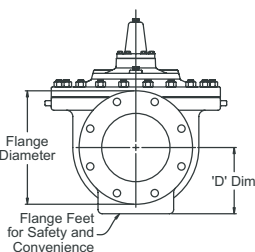
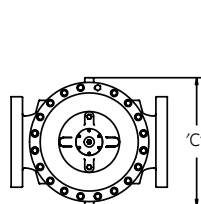
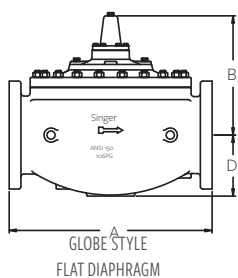

See pilot system information, page 207.
For additional Engineering notes, see page 242.

MODEL 106-AC

Anti-Cavitation Control Valve

VALVE DATA (METRIC UNITS)

SIZE	DWG	STANDARD	ROLLING DIAPHRAGM SYSTEM								
			MM	REF	ANSI	150 MM	200 MM	250 MM	300 MM	400 MM	500 MM
GLOBE DIMENSIONS			ALL FIGURES SHOWN IN MM UNLESS OTHERWISE STATED.								
Lay Length	A	FNPT	-	-	-	-	-	-	-	-	-
Centerline to Bottom	D	FNPT	-	-	-	-	-	-	-	-	-
Lay Length	A	150F	508	645	756	864	1051	1321	1562	1930	
Centerline to Bottom	D	150F	142	194	210	244	308	367	435	597	
Lay Length	A	300F	533	670	791	902	1105	1362	1607	1981	
Centerline to Bottom	D	300F	161	200	229	264	334	400	499	648	
COMMON DIMENSIONS (GLOBE)											
Width	C		324	409	460	540	687	889	1262	1422	
Height (To Stem Cap) Globe	E		346	455	562	603	770	902	1162	1550	
Body Port Tapping	FNPT	Inches	3/8	1/2	3/4	3/4	3/4	3/4	3/4	1	
Stem Cap Plug	MNPT	Inches	3/8	3/8	3/4	3/4	3/4	3/4	3/4	1	
Cover Port Tapping	FNPT	Inches	1/2	1/2	3/4	3/4	3/4	3/4	3/4	1	
Valve Stroke		mm	43	73	83	95	120	141	150	229	
Displaced Bonnet Volume (Liters)			2	4	6	9	26	34	56	163	
Approximate Shipping Weight (Kilograms)			163	300	408	635	1089	1565	2268	6124	
Flow Capacities			Please consult with us								
MAXIMUM PRESSURE RATINGS (DUCTILE ONLY)											
Bar ¹	FNPT		-	-	-	-	-	-	-	-	
Bar	150F		17	17	17	17	17	17	17	17	
Bar ¹	300F		27.6	27.6	27.6	27.6	27.6	27.6	27.6	27.6	
MAXIMUM TEMPERATURE											
Celcius			82°	82°	82°	82°	82°	82°	82°	82°	

¹Valves rated and stamped 400 psi as standard. Valves rated and stamped 600 psi on request.

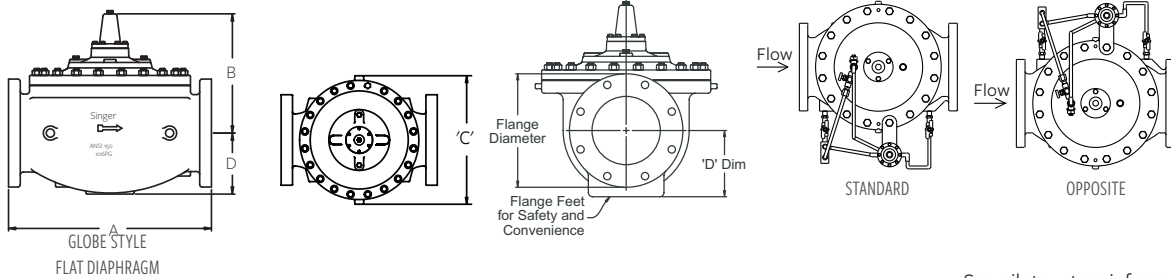

See pilot system information, page 207.
For additional Engineering notes, see page 242.

MODEL 106-AC

Anti-Cavitation Control Valve

AC VALVE DATA (ISO UNITS)

SIZE	DWG	STANDARD	FLAT DIAPHRAGM SYSTEM									
			MM	REF	ISO	25 MM	32 MM	40 MM	50 MM	65 MM	80 MM	100 MM
GLOBE DIMENSIONS			ALL FIGURES SHOWN IN MM UNLESS OTHERWISE STATED									
Lay Length	A	BSPT	171	171	171	238	279	343	-	-	-	-
Centerline to Bottom	D	BSPT	64	64	64	70	86	93	-	-	-	-
Lay Length	A	PN10 / PN16	-	-	229	238	279	318	381	508	645	-
Centerline to Bottom	D	PN10 / PN16	-	-	83	76	89	100	117	142	200	-
Lay Length	A	PN25 / PN40	-	-	229	238	295	318	397	533	670	-
Centerline to Bottom	D	PN25 / PN40	-	-	83	76	89	100	129	161	200	-
COMMON DIMENSIONS (GLOBE)												
Width	C		124	124	156	152	208	235	276	425	549	-
Height (To Stem Cap) Globe	E		111	111	111	121	191	203	232	298	379	-
Body Port Tapping	FNPT	Inches	3/8	3/8	3/8	3/8	3/8	3/8	3/8	3/8	3/8	1/2
Stem Cap Plug	MNPT	Inches	3/8	3/8	3/8	3/8	3/8	3/8	3/8	3/8	3/8	3/8
Cover Port Tapping	FNPT	Inches	3/8	3/8	3/8	3/8	3/8	3/8	3/8	3/8	1/2	1/2
Valve Stroke		mm	14	14	14	14	25	29	37	43	73	-
Displaced Bonnet Volume (Liters)			0.03	0.03	0.03	0.1	0.3	0.3	0.8	2.1	6.3	-
Approximate Shipping Weight (Kilograms)			11	11	11	20	36	57	113	181	317	-
Capacities	Please consult with us											
MAXIMUM PRESSURE RATINGS (DUCTILE ONLY)												
Bar	BSPT		27.6	27.6	27.6	27.6	27.6	27.6	-	-	-	-
Bar	PN16		-	-	-	16	16	16	16	16	16	16
Bar	PN25		-	-	-	25	25	25	25	25	25	25
MAXIMUM TEMPERATURE												
Celsius			82°	82°	82°	82°	82°	82°	82°	82°	82°	82°

¹Valves rated and stamped 27.6 bar as standard. Valves rated and stamped 41 bar on request.

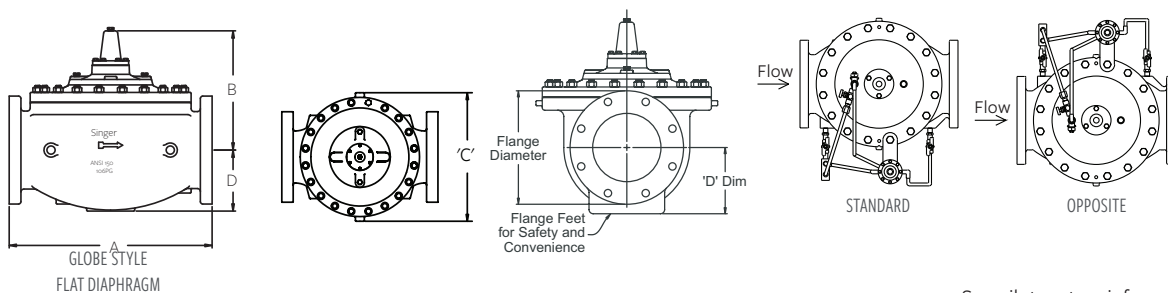

See pilot system information, page 207.
For additional Engineering notes, see page 242.

MODEL 106-AC

Anti-Cavitation Control Valve

AC VALVE DATA (ISO UNITS)

SIZE	DWG	STANDARD	ROLLING DIAPHRAGM SYSTEM							
MM	REF	ISO	150 MM	200 MM	250 MM	300 MM	400 MM	500 MM	600 MM	900 MM
GLOBE DIMENSIONS			ALL FIGURES SHOWN IN MM UNLESS OTHERWISE STATED							
Lay Length	A	BSPT	-	-	-	-	-	-	-	-
Centerline to Bottom	D	BSPT	-	-	-	-	-	-	-	-
Lay Length	A	PN10 / PN16	508	645	756	864	1051	1321	1562	1930
Centerline to Bottom	D	PN10 / PN16	142	200	210	244	308	367	435	597
Lay Length	A	PN25 / PN40	533	670	791	902	1105	1362	1607	1981
Centerline to Bottom	D	PN25 / PN40	161	200	229	264	334	400	499	648
COMMON DIMENSIONS (GLOBE)										
Width	C		324	409	460	540	687	889	1262	1422
Height (To Stem Cap) Globe	E		346	455	562	603	770	902	1162	1550
Body Port Tapping	FNPT	Inches	$\frac{3}{8}$	$\frac{1}{2}$	$\frac{3}{4}$	$\frac{3}{4}$	$\frac{3}{4}$	$\frac{3}{4}$	$\frac{3}{4}$	1
Stem Cap Plug	MNPT	Inches	$\frac{3}{8}$	$\frac{3}{8}$	$\frac{3}{4}$	$\frac{3}{4}$	$\frac{3}{4}$	$\frac{3}{4}$	$\frac{3}{4}$	1
Cover Port Tapping	FNPT	Inches	$\frac{1}{2}$	$\frac{1}{2}$	$\frac{3}{4}$	$\frac{3}{4}$	$\frac{3}{4}$	$\frac{3}{4}$	$\frac{3}{4}$	1
Valve Stroke		mm	43	73	83	95	120	141	150	229
Displaced Bonnet Volume (Liters)			2	4	6	9	26	34	56	163
Approximate Shipping Weight (Kilograms)			163	300	408	635	1089	1565	2268	6124
Flow Capacities			Please consult with us							
MAXIMUM PRESSURE RATINGS (DUCTILE ONLY)										
Bar		BSPT	-	-	-	-	-	-	-	-
Bar		PN16	16	16	16	16	16	16	16	16
Bar		PN25	25	25	25	25	25	25	25	25
MAXIMUM TEMPERATURE										
Celcius			82°	82°	82°	82°	82°	82°	82°	82°

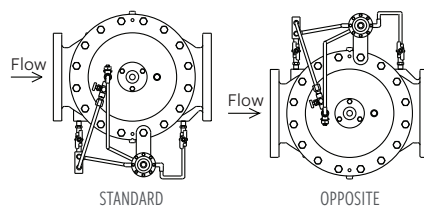
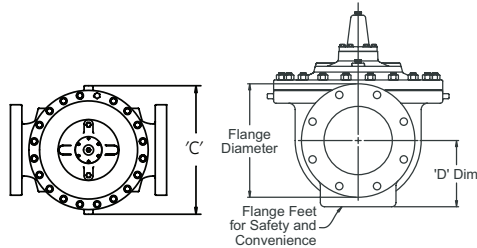
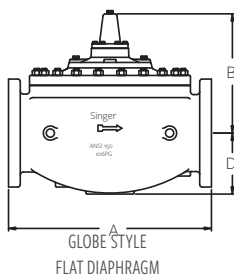

See pilot system information, page 207.
For additional Engineering notes, see page 242.

PRESSURE REDUCING VALVES

When faced with extreme pressures or anything in between, our pressure reducing valves maintain a uniform downstream pressure. Regardless of the problem, regardless of the application, our valves perform under pressure.

Want extra security? That's a job for our PR-SM, a PR valve fitted with an integral back-up system. Need to reduce high nighttime pressure? Our Pressure / Flow Control valve works wonders. Do you have a tricky application without a reliable solution in sight? Contact us. We welcome the challenge.

MODELS 106-PR-SM / 206-PR-SM

Pressure Reducing Control Valve with Integral Back-Up

KEY FEATURES

- Ideal for applications where failure is not an option
- Includes a back-up system to protect against diaphragm or pilot failure
- Reduces requirement for immediate service
- Provides downstream surge protection

PRODUCT OVERVIEW

The 106-PR-SM and 206-PR-SM series control valves are engineered to be used anywhere pressure reducing valve failure is unacceptable. These valves have a second and independent operating system superimposed upon the standard primary system. With the assurance of a back-up system, maintenance schedules may be extended as pressures will continue to be controlled even in the event of failure with the primary system.

Under normal pressure reducing conditions, the primary pilot senses the downstream pressure through a connection at the valve outlet. Under flowing conditions, the pilot reacts to small changes in pressure to control the valve position by modulating the pressure above the diaphragm in the lower operating chamber. The downstream pressure is maintained virtually steady at the pilot set-point that is adjustable.

Should the primary pilot system and/or main valve fail to control the downstream pressure, the independent back-up pilot system will begin to operate. It controls the pressure above the diaphragm in the second operating chamber. The back-up pilot is set slightly higher than the primary pilot. The forces now operating in the top chamber assume control of the inner valve assembly and maintain pressure reducing control. During back-up operation only, there is a small (1 USGPM / 0.063 L/s) continuous discharge that should be taken to drain.

The secondary pilot continually senses the downstream pressure. Should there be a rapid rise in downstream pressure for any reason, the secondary pilot will respond quickly, and will pressurize the top chamber. This will compliment the primary pressure reducing controls and provide faster response.



MODELS 106-PR-SM / 206-PR-SM

Pressure Reducing Control Valve with Integral Back-Up

TYPICAL APPLICATION

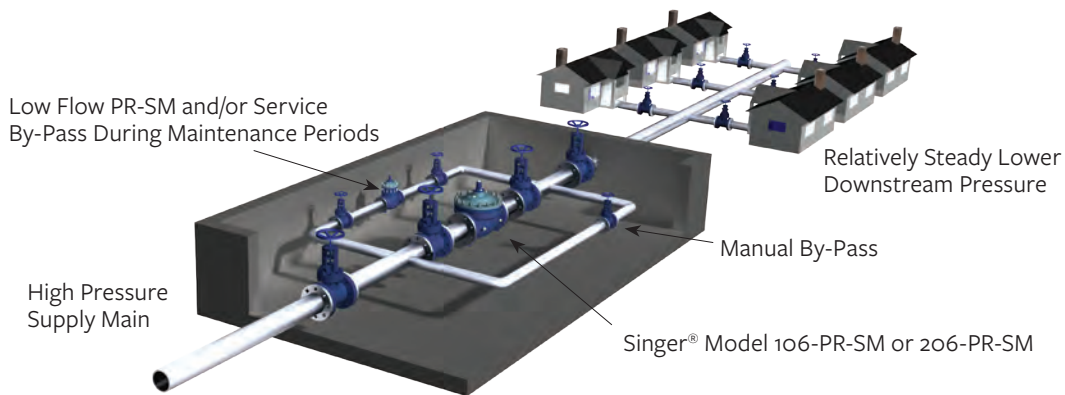

SCHEMATIC DRAWING

NO.	PART
1	Main Valve - 106-PGM or 206-PGM
2	Isolation Valves - (2A, 2B, 8, 9A, 9B)
3	Strainer - 40 Mesh Stainless Steel Screen (3A, 3B)
4	Model 81-RP Pilot (Back-up)
5	Fixed Restriction
6	Model 26 Flow Stabilizer (sizes 8" / 200 mm 106, 10" / 250 mm 206 and smaller is included)
7	Model 160 PR Pilot (Primary)
8	Isolation Valves - (2A, 2B, 8, 9A, 9B)
9	Isolation Valves - (2A, 2B, 8, 9A, 9B)
10	Limit Switch Assembly - SPDT - Optional

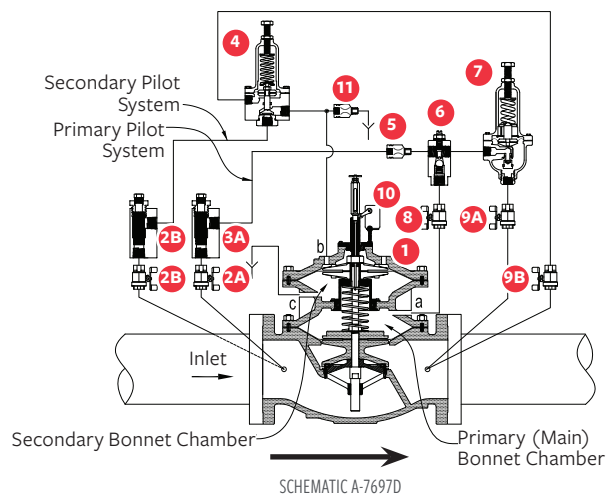

STANDARD MATERIALS

Standard materials for pilot system components are:

ASTM B-62 bronze or ASTM B-16 brass

AISI 303 / 316 stainless steel trim

SELECTION SUMMARY

1. Select the valve series and size with sufficient capacity
2. Check the operating flow against valve minimum.
3. Provide a smaller valve in parallel to facilitate maintenance and low flow capability, if required.
4. If the outlet pressure is less than 35% of the inlet pressure, check for cavitation.
5. Ensure that the valve and flange working pressure rating exceeds the maximum operating pressure.

ORDERING INSTRUCTIONS

Refer to page 244 for the order form and ordering instructions.

Additionally, include the following information for this product:

1. Single chamber (106) or (206)
2. Outlet pressure range

MODELS 106-PR-SM / 206-PR-SM

Pressure Reducing Control Valve with Integral Back-Up

106-PR-SM

FLOW CAPACITY (SEE 106-PGM IN MAIN VALVE SECTION FOR OTHER VALVE DATA)

Size (Inches)	3"	4"	6"	8"	10"	12"	14"	16"	20"	24"
Size (mm)	80 mm	100 mm	150 mm	200 mm	250 mm	300 mm	350 mm	400 mm	500 mm	600 mm
Minimum (USGPM) Flat Diaphragm	5	10	20	40	-	-	-	-	-	-
Minimum (USGPM) Rolling Diaphragm	-	-	1	1	3	3	3	3	10	10
Minimum (L/s) Flat Diaphragm	0.32	0.63	1.26	2.52	-	-	-	-	-	-
Minimum (L/s) Rolling Diaphragm	-	-	0.06	0.06	0.19	0.19	0.19	0.19	0.63	0.63
Maximum Continuous (USGPM)	460	800	1800	3100	4900	7000	8500	11000	17500	25000
Maximum Continuous (L/s)	29	50	114	196	309	442	536	694	1104	1577

206-PR-SM

FLOW CAPACITY (SEE 206-PGM IN MAIN VALVE SECTION FOR OTHER VALVE DATA)

Size (Inches)	4"	6"	8"	10"	12"	16"	18"	20"	24 x 16"	24 x 20"	28"	30"	32"	36"
Size (mm)	100 mm	150 mm	200 mm	250 mm	300 mm	400 mm	450 mm	500 mm	600 x 400 mm	600 x 500 mm	700 mm	750 mm	800 mm	900 mm
Minimum (USGPM) Flat Diaphragm	5	10	20	40	-	-	-	-	-	-	-	-	-	-
Minimum (USGPM) Rolling Diaphragm	-	-	-	-	3	3	3	3	3	3	10	10	10	10
Minimum (L/s) Flat Diaphragm	0.32	0.63	1.26	2.52	-	-	-	-	-	-	-	-	-	-
Minimum (L/s) Rolling Diaphragm	-	-	-	-	0.19	0.19	0.19	0.19	0.19	0.19	0.63	0.63	0.63	0.63
Maximum Continuous (USGPM)	580	1025	2300	4100	6400	9230	16500	16500	16500	21700	33600	33650	33700	33800
Maximum Continuous (L/s)	37	65	145	259	404	582	1041	1041	1041	1370	2120	2123	2126	2132

MODELS 106-PFC / 206-PFC

Pressure Flow Control (Modulation) Valve

KEY FEATURES

- Reduces downstream pressure when demand is low to reduce leakage and pipe breaks.
- Compensates for pressure loss in the pipe to keep a fairly constant pressure at a distant point. This reduces the pressure during low flow in most of the system.
- Simple to set-up and adjust.
- Maximum pressure increase can be limited by simple adjustment.
- Pressure increase is adjustable.

PRODUCT OVERVIEW

The 106-PFC / 206-PFC Pressure Flow Control Valve is a pressure reducing valve with a special (Patented) pilot that increases downstream pressure as flow increases.

The PFC valve controls the downstream pressure as a function of flow. This increased downstream pressure compensates partially for pipe friction and therefore maintains a relatively constant pressure at some remote location. The PFC valve will deliver consistent performance without any electrical components and is not affected by flooding. The valve can be used wherever a standard PRV is installed.

Please note that the downstream (controlled) pressure increases from low flow to selected maximum flow but reduces at flows higher than the selected maximum. This is due to the increased pressure drop of the orifice plate. If this reduction of the controlled pressure past the design maximum flow is a problem, contact us or your Singer® representative for an engineered solution.



TYPICAL APPLICATION

An orifice plate immediately downstream of the PFC Control Valve produces 3 psi / 0.2 bar pressure drop, at maximum flow. This pressure differential is applied to each side of an actuating diaphragm which is connected to the yoke of the pressure reducing pilot. Increasing the differential raises the pilot setting and raises downstream pressure to maintain virtually steady pressure on a critical distance user.

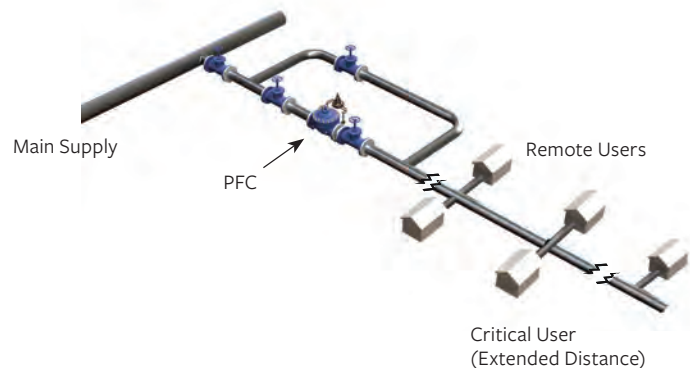

MODELS 106-PFC / 206-PFC

Pressure Flow Control (Modulation) Valve

SCHEMATIC DRAWING

NO.	PART
1	Main Valve - 106-PG or 206-PG
2	Isolation Valve (2A, 2B, 2C)
3	Strainer - 40 Mesh
4	Model 26 Flow Stabilizer / Opening speed Control Standard on 8" (200 mm) 106 / 10" (250 mm) 206 and Smaller Optional on 10" (250 mm) 106 / 12" (300 mm) 206 and Larger
5	Fixed Restriction
6	Model 160-PFC Pressure / Flow Control Pilot
7	Orifice housing and plate
8	Test Valve
9	Speed Control
10	Fixed Restriction
11	PIP Adjustment - Model 852-B

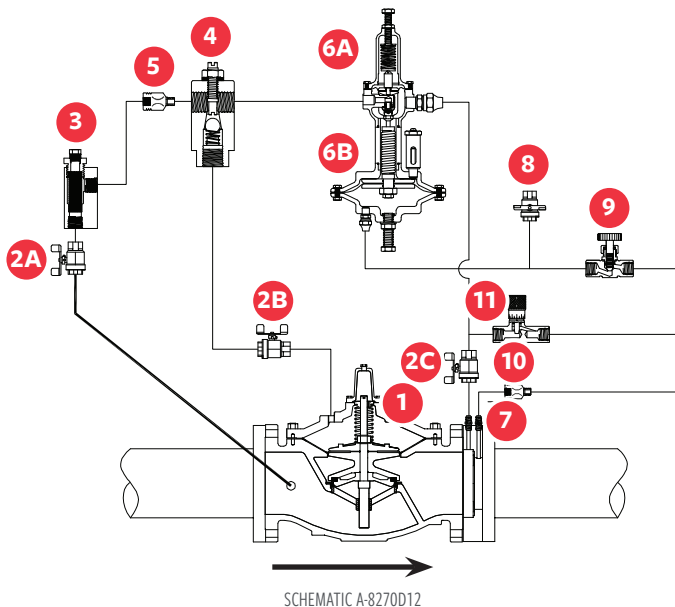

SELECTION SUMMARY

- The Singer® model 106-PFC / 206-PFC should be sized as a normal pressure reducing valve. Refer to section 106-PR / 206-PR, page 96, for size selection and main pilot spring ranges.
- Installation is the same as a standard pressure reducing valve. See section 106-PR / 206-PR, page 96.
- Maximum pressure increase over base setting:
35 psi / 2.4 bar.
- For correct application provide
 - Maximum & minimum inlet pressure and base (minimum) outlet pressure setting
 - Maximum & minimum flow rates
 - Pressure increase _____ psi / _____ bar at _____ USGPM / L/s
 - Maximum pressure increase at any flow _____ psi / _____ bar.
- Ensure the flange ratings exceed the maximum working pressure.

ORDERING INSTRUCTIONS

Refer to page 244 for the order form and ordering instructions.

Additionally, include the following information for this product:

- Single chamber (106) or (206)
- Outlet pressure range
- Minimum / maximum flow rate
- Pressure increase at high flow

MODELS 106-PFC / 206-PFC

Pressure Flow Control (Modulation) Valve

106-PFC

FLOW CAPACITY

(SEE 106-PG IN MAIN VALVE SECTION FOR OTHER VALVE DATA)

Size (Inches)	3"	4"	6"	8"	10"	12"	14"	16"	20"	24"	36"
Size (mm)	80 mm	100 mm	150 mm	200 mm	250 mm	300 mm	350 mm	400 mm	500 mm	600 mm	900 mm
Minimum Continuous (USGPM) Flat Diaphragm	2	4	20	40	-	-	-	-	-	-	-
Minimum Continuous (USGPM) Rolling Diaphragm	-	-	1	1	3	3	3	3	10	10	20
Minimum Continuous (L/s) Flat Diaphragm	0.13	0.25	1.3	2.5	-	-	-	-	-	-	-
Minimum Continuous (L/s) Rolling Diaphragm	-	-	0.1	0.1	0.2	0.2	0.2	0.2	0.6	0.6	1.3
Maximum Continuous (USGPM)	460	800	1800	3100	4900	7000	8500	11000	17500	25800	55475
Maximum Continuous (L/s)	29	50	114	196	309	442	536	694	1104	1628	3500

206-PFC

FLOW CAPACITY

(SEE 206-PG IN MAIN VALVE SECTION FOR OTHER VALVE DATA)

Size (Inches)	4"	6"	8"	10"	12"	16"	18"	20"	24 x 16"	24 x 20"	28"	30"	32"	36"	40"	48"
Size (mm)	100 mm	150 mm	200 mm	250 mm	300 mm	400 mm	450 mm	500 mm	600 x 400 mm	600 x 500 mm	700 mm	750 mm	800 mm	900 mm	1000 mm	1200 mm
Minimum Continuous (USGPM) Flat Diaphragm	2	4	20	40	-	-	-	-	-	-	-	-	-	-	-	-
Minimum Continuous (USGPM) Rolling Diaphragm	-	-	1	1	3	3	3	3	3	3	10	10	10	10	20	20
Minimum Continuous (L/s) Flat Diaphragm	0.13	0.25	1.3	2.5	-	-	-	-	-	-	-	-	-	-	-	-
Minimum Continuous (L/s) Rolling Diaphragm	-	-	0.06	0.06	0.2	0.2	0.2	0.2	0.2	0.2	0.6	0.6	0.6	0.6	1.3	1.3
Maximum Continuous (USGPM)	580	1025	2300	4100	6400	9230	16500	16500	16500	21700	33600	33650	33700	33800	55475	55475
Maximum Continuous (L/s)	37	65	145	259	404	582	1040	1040	1040	1370	2120	2123	2126	2132	3500	3500

MODELS 106-PR / 206-PR

Pressure Reducing Valve

KEY FEATURES

- Ideal for maintaining accurate downstream pressure
- Responds quickly and effectively

PRODUCT OVERVIEW

The 106-PR and 206-PR series pressure reducing valves are based on the 106-PG or 206-PG main valves.

The pilot valves sense the downstream pressure through a connection at the valve outlet. Under flowing conditions, the pilot reacts to small changes in pressure to control the valve position by modulating the pressure above the diaphragm. The downstream pressure is maintained virtually steady at the pilot set-point.

In typical pressure reducing applications, the standard port model 206-PR is often the best selection.



TYPICAL APPLICATION

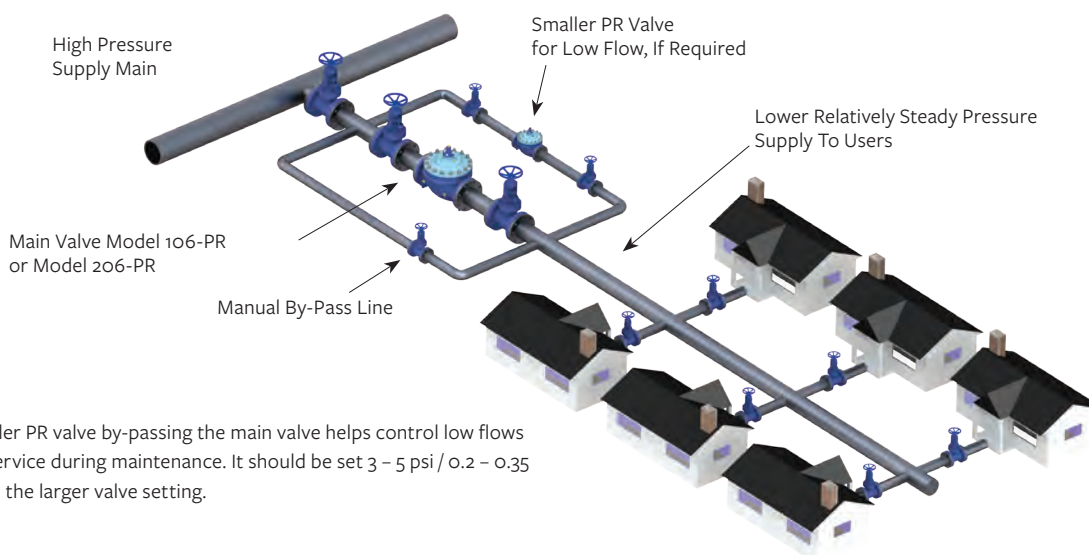

Note: The smaller PR valve by-passing the main valve helps control low flows and provides service during maintenance. It should be set 3 – 5 psi / 0.2 – 0.35 bar higher than the larger valve setting.

Singer® single rolling diaphragm technology 6" / 150 mm and larger have extremely precise control, even at low flows, making smaller by-pass valves unnecessary except for possible bypass during maintenance.

MODELS 106-PR / 206-PR

Pressure Reducing Valve

SCHEMATIC DRAWING

NO.	PART
1	Main Valve - 106-PG or 206-PG
2	Isolation Valve - Standard 4" / 100 mm and Larger
3	Strainer - Standard 4" / 100 mm and Larger
4*	Model 26 Flow Stabilizer / Opening Speed Control Standard on valves 8" / 200 mm 106, 10" / 250 mm 206 and Smaller
5	Fixed Restriction
6	Isolation Valve - Standard 4" / 100 mm and Larger
7	Model 160 Pilot Specify for 5 to 50 psi / 0.35 to 3.5 bar, 10 to 80 psi / 0.70 to 5.5 bar, 20 to 200 psi / 1.38 to 13.8 bar, 100 to 300 psi / 6.9 to 20.7 bar.
8	Isolation Valve - Standard All Sizes

Note: SRD shown is available for 6" 106-PG and larger.

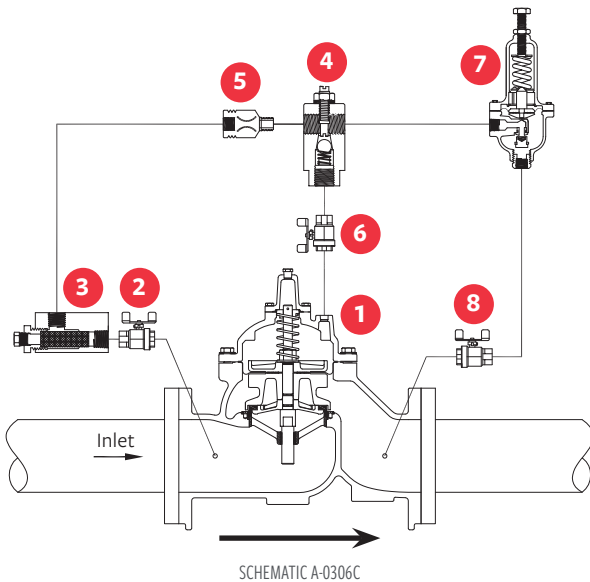

STANDARD MATERIALS

Standard materials for pilot system components are:

- ASTM B62 bronze or ASTM B16 brass
- AISI 303 / 316 stainless steel trim
- Buna-N / EPDM diaphragm and seals

SELECTION SUMMARY

1. Select the valve series and size with sufficient capacity
2. Check the operating flow against valve minimum.
3. If the outlet pressure is less than 35% of the inlet pressure, check for cavitation.
4. Ensure that the flange rating exceeds the maximum operating pressure.

ORDERING INSTRUCTIONS

Refer to page 244 for the order form and ordering instructions.

Additionally, include the following information for this product:

1. 106 or 206
2. Pilot range

MODELS 106-PR / 206-PR

Pressure Reducing Valve

106-PR

FLOW CAPACITY (SEE 106-PG IN MAIN VALVE SECTION FOR OTHER VALVE DATA)

Size (Inches)	½"	¾"	1"	1 ¼"	1 ½"	2"	2 ½"	3"	4"
Size (mm)	15 mm	19 mm	25 mm	32 mm	40 mm	50 mm	65 mm	80 mm	100 mm
Minimum (USGPM) Flat Diaphragm	1	1	1	1	1	5	5	5	10
Minimum (L/s) Flat Diaphragm	0.06	0.06	0.06	0.06	0.06	0.06	0.06	0.13	0.25
Maximum Continuous (USGPM)	12	19	49	93	125	210	300	460	800
Maximum Continuous (L/s)	0.8	1	3	6	8	13	19	29	50

106-PR

FLOW CAPACITY (SEE 106-PG IN MAIN VALVE SECTION FOR OTHER VALVE DATA)

Size (Inches)	6"	8"	10"	12"	14"	16"	20"	24"	36"
Size (mm)	150 mm	200 mm	250 mm	300 mm	350 mm	400 mm	500 mm	600 mm	900 mm
Minimum (USGPM) Flat Diaphragm	20	40	-	-	-	-	-	-	-
Minimum (USGPM) Rolling Diaphragm	1	1	3	3	3	3	10	10	20
Minimum (L/s) Flat Diaphragm	1.3	2.5	-	-	-	-	-	-	-
Minimum (L/s) Rolling Diaphragm	0.06	0.06	0.2	0.2	0.2	0.2	0.6	0.6	1.3
Maximum Continuous (USGPM)	1800	3100	4900	7000	8500	11000	17500	25800	55475
Maximum Continuous (L/s)	114	196	309	442	536	694	1104	1628	3500

206-PR

FLOW CAPACITY (SEE 206-PG IN MAIN VALVE SECTION FOR OTHER VALVE DATA)

Size (Inches)	3"	4"	6"	8"	10"	12"	16"	18"	20"
Size (mm)	80 mm	100 mm	150 mm	200 mm	250 mm	300 mm	400 mm	450 mm	500 mm
Minimum (USGPM) Flat Diaphragm	1	2	4	20	40	-	-	-	-
Minimum (USGPM) Rolling Diaphragm	-	-	-	1	1	3	3	3	3
Minimum (L/s) Flat Diaphragm	0.06	0.13	0.25	1.3	2.5	-	-	-	-
Minimum (L/s) Rolling Diaphragm	-	-	-	0.06	0.06	0.19	0.19	0.19	0.19
Maximum Continuous (USGPM)	300	580	1025	2300	4100	6400	9230	16500	16500
Maximum Continuous (L/s)	19	37	65	145	260	404	582	1040	1040

206-PR

FLOW CAPACITY (SEE 206-PG IN MAIN VALVE SECTION FOR OTHER VALVE DATA)

Size (Inches)	24 x 16"	24 x 20"	28"	30"	32"	36"	40"	48"
Size (mm)	600 x 400 mm	600 x 500 mm	700 mm	750 mm	800 mm	900 mm	1000 mm	1200 mm
Minimum (USGPM) Rolling Diaphragm	3	3	10	10	10	10	20	20
Minimum (L/s) Rolling Diaphragm	0.2	0.2	0.6	0.6	0.6	0.6	1.3	1.3
Maximum Continuous (USGPM)	16500	21700	33600	33650	33700	33800	55475	55475
Maximum Continuous (L/s)	1041	1370	2120	2123	2126	2132	3500	3500

MODELS 106-PR-48 / 206-PR-48

Pressure Reducing Valve with Low Flow By-Pass

KEY FEATURES

- Maintains stable flow right down to zero
- Precise and reliable pressure setting
- By-pass piped in parallel to reduce space requirements

PRODUCT OVERVIEW

The 106-PR-48 and 206-PR-48 series pressure reducing valves with low flow by-pass are based on the 106-PG or 206-PG main valve. In addition, a direct acting pressure reducing valve is piped in parallel, using the main valve back port connections.

The pilot valve senses the downstream pressure through a connection at the main valve outlet. Under flowing conditions, the pilot reacts to small changes in pressure to control the main valve position by modulating the pressure above the diaphragm. The downstream pressure is maintained virtually steady at the pilot set-point.

The by-pass valve is set 5 psi / 0.35 bar higher than the main valve. Under low flow conditions, the main PR valve closes and the by-pass stays open, controlling the pressure at very low flows without seat chatter.

In typical pressure reducing applications, the standard port Model 206-PR-48 is often the best selection.



TYPICAL APPLICATION

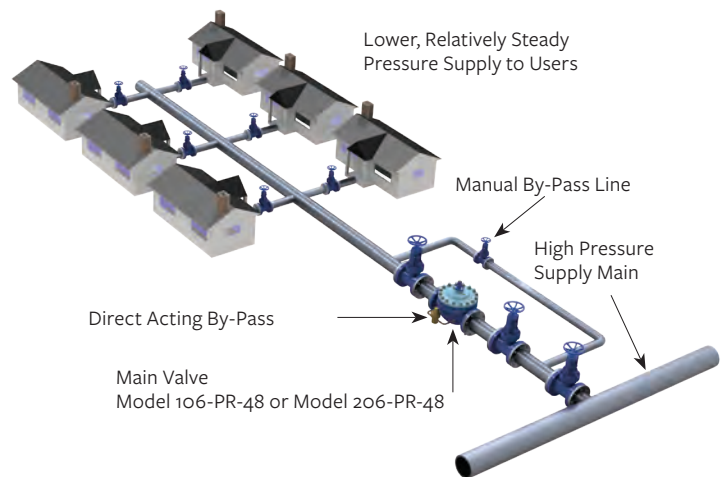

MODELS 106-PR-48 / 206-PR-48

Pressure Reducing Valve with Low Flow By-Pass

SCHEMATIC DRAWING

NO.	PART
1	Main Valve - 106-PG or 206-PG
2	Isolation Valves - Standard 4" / 100 mm and Larger
3	Strainer - Standard 4" / 100 mm and Larger
4	Model 26 Flow Stabilizer / Opening Speed Control Standard on Valves 8" / 200 mm 106, 10" / 250 mm 206 and Smaller
5	Fixed Restriction
6	Isolation Valves - Standard 4" / 100 mm and Larger
7	Model 160 Pilot Specify for 5 to 50 psi / 0.35 to 3.5 bar, 10 to 80 psi / 0.70 to 5.5 bar, 20 to 200 psi / 1.38 to 13.8 bar, 100 to 300 psi / 6.9 to 20.7 bar.
8	Isolation Valve - Standard All Sizes
9	Direct Acting By-Pass - Range 30 - 145 psi / 2.07 - 10 bar
10	Isolation Valve - Standard All Sizes

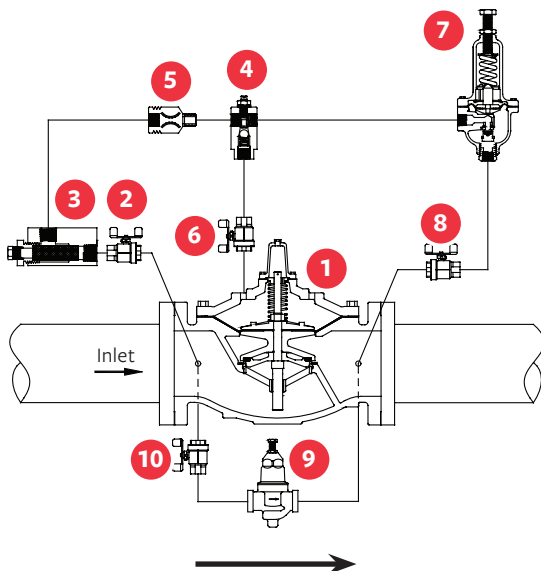

SCHEMATIC A-8063E

STANDARD MATERIALS

Standard materials for pilot system components are:

- ASTM B-62 bronze or ASTM B-16 brass;
- AISI 303 / 316 stainless steel trim

SELECTION SUMMARY

1. Select the main PR valve series and size with sufficient capacity. Note that large Singer® valves (6" / 150 mm 106 & 12" / 300 mm 206 and up) have extremely precise control, even at low flows, making by-pass valves generally unnecessary for stable control, due to Single Rolling Diaphragm technology. Model PR-48 valves are usually required only for valve sizes with significant minimum flows. (3" / 80 mm to 8" / 200 mm 106 and 4" / 100 mm to 10" / 250 mm 206).
2. If the outlet pressure is less than 35% of the inlet pressure, check for cavitation.
3. Ensure that the flange rating exceeds the maximum operating pressure.
4. Consider using a manual main by-pass line if necessary for service during maintenance periods

ORDERING INSTRUCTIONS

Refer to page 244 for the order form and ordering instructions.

Additionally, include the following information for this product:

1. Single chamber (106) or (206)
2. Pilot range

MODELS 106-PR-48 / 206-PR-48

Pressure Reducing Valve with Low Flow By-Pass

106-PR-48

FLOW CAPACITY (SEE 106-PG IN MAIN VALVE SECTION FOR OTHER VALVE DATA)

Size (Inches)	3"	4"	6"	8"
Size (mm)	80 mm	100 mm	150 mm	200 mm
Minimum (USGPM) Flat Diaphragm	0	0	0	0
Minimum (L/s) Flat Diaphragm	0	0	0	0
Maximum Continuous (USGPM) Flat Diaphragm	460	800	1800	3100
Maximum Continuous (L/s) Flat Diaphragm	29	50	114	196

206-PR-48

FLOW CAPACITY (SEE 206-PG IN MAIN VALVE SECTION FOR OTHER VALVE DATA)

Size (Inches)	4"	6"	8"	10"
Size (mm)	100 mm	150 mm	200 mm	250 mm
Minimum (USGPM) Flat Diaphragm	0	0	0	0
Minimum (L/s) Flat Diaphragm	0	0	0	0
Maximum Continuous (USGPM) Flat Diaphragm	580	1025	2300	4100
Maximum Continuous (L/s) Flat Diaphragm	37	65	145	259

MODELS 106-PR-C / 206-PR-C

Pressure Reducing and Check Valve

KEY FEATURES

- Excellent low flow stability
- Drip-tight closing on return flow
- Easily and precisely set downstream pressure

PRODUCT OVERVIEW

The 106-PR-C and 206-PR-C pressure reducing and check valves are based on the 106-PG or 206-PG main control valve.

The pilot valve senses the downstream pressure through a connection at the valve outlet. Under flowing conditions, the pilot reacts to small changes in pressure to control the valve position by modulating the pressure above the diaphragm. The downstream pressure is maintained relatively steady at the pilot set-point.

The pilot check valves direct downstream pressure above the diaphragm to close the valve when the system pressures reverse (when the downstream pressure is higher than the upstream).

In typical pressure reducing applications, the standard port model 206-PR-C is often the best selection.



TYPICAL APPLICATION

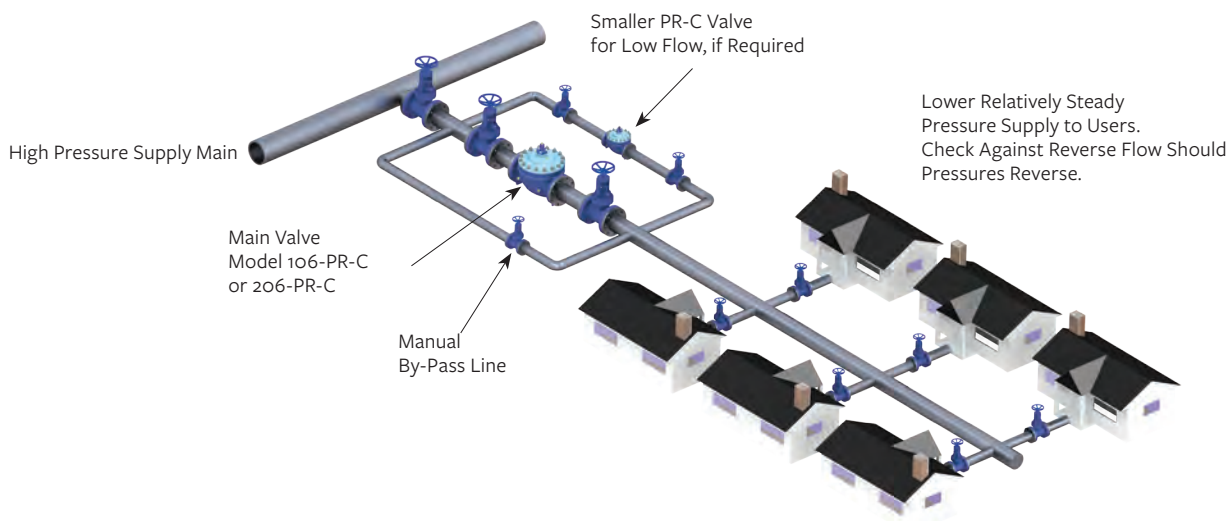

MODELS 106-PR-C / 206-PR-C

Pressure Reducing and Check Valve

SCHEMATIC DRAWING

NO.	PART
1	Main Valve - 106-PG or 206-PG
2	Isolation Valve - Standard 4" / 100 mm and Larger
3	Strainer - Standard 4" / 100 mm and Larger
4*	Model 26 Flow Stabilizer / Opening Speed Control Standard on Valves 8" / 200 mm 106, 10" / 250 mm 206 and Smaller
5	Fixed Restriction
6	Isolation Valve - Standard 4" / 100 mm and Larger
7	Model 160 Pilot Specify for 5 to 50 psi / 0.35 to 3.5 bar, 10 to 80 psi / 0.70 to 5.5 bar, 20 to 200 psi / 1.38 to 13.8 bar, 100 to 300 psi / 6.9 to 20.7 bar.
8	Isolation Valve - Standard All Sizes
9	Check Valve - Model 10
10	Check Valve - Model 10

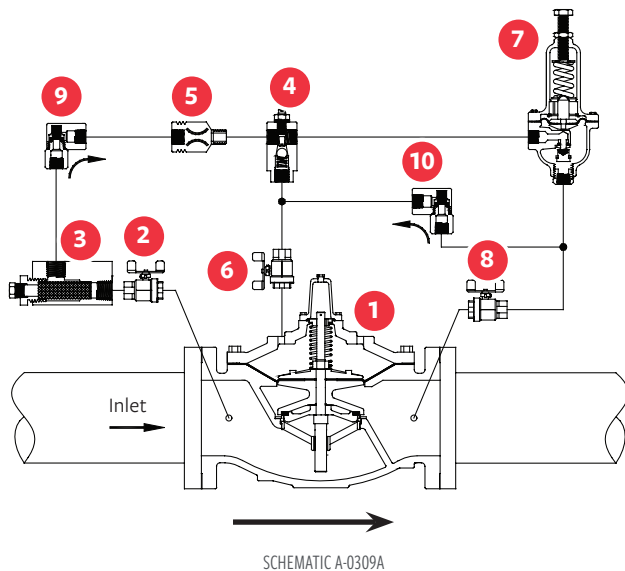

STANDARD MATERIALS

Standard materials for pilot system components are:

- ASTM B62 bronze or ASTM B16 brass
- AISI 303/316 stainless steel trim
- Buna-N / EPDM diaphragm and seals

SELECTION SUMMARY

1. Select the valve series and size with sufficient capacity
2. Check the operating flow against valve minimum
3. Provide a smaller valve in parallel to facilitate maintenance and low flow capability, if required.
4. If the outlet pressure is less than 35% of the inlet pressure, check for cavitation.
5. Ensure that the flange rating exceeds the maximum operating pressure.

ORDERING INSTRUCTIONS

Refer to page 244 for the order form and ordering instructions.

Additionally, include the following information for this product:

1. Full port (106) or standard port (206)
2. Pilot range

MODELS 106-PR-C / 206-PR-C

Pressure Reducing and Check Valve

106-PR-C

FLOW CAPACITY (SEE 106-PG IN MAIN VALVE SECTION FOR OTHER VALVE DATA)

Size (Inches)	½"	¾"	1"	1 ¼"	1 ½"	2"	2 ½"	3"	4"
Size (mm)	15 mm	19 mm	25 mm	32 mm	40 mm	50 mm	65 mm	80 mm	100 mm
Minimum (USGPM) Flat Diaphragm	1	1	1	1	1	1	1	2	4
Minimum (L/s) Flat Diaphragm	0.06	0.06	0.06	0.06	0.06	0.06	0.06	0.13	0.25
Maximum Continuous (USGPM)	12	19	49	93	125	210	300	460	800
Maximum Continuous (L/s)	0.8	1	3	6	8	13	19	29	50

106-PR-C

FLOW CAPACITY (SEE 106-PG IN MAIN VALVE SECTION FOR OTHER VALVE DATA)

Size (Inches)	6"	8"	10"	12"	14"	16"	20"	24"	36"
Size (mm)	150 mm	200 mm	250 mm	300 mm	350 mm	400 mm	500 mm	600 mm	900 mm
Minimum (USGPM) Flat Diaphragm	20	40	-	-	-	-	-	-	-
Minimum (USGPM) Rolling Diaphragm	1	1	3	3	3	3	10	10	20
Minimum (L/s) Flat Diaphragm	1.3	2.5	-	-	-	-	-	-	-
Minimum (L/s) Rolling Diaphragm	0.06	0.06	0.2	0.2	0.2	0.2	0.6	0.6	1.3
Maximum Continuous (USGPM)	1800	3100	4900	7000	8500	11000	17500	25800	55475
Maximum Continuous (L/s)	114	196	309	442	536	694	1104	1628	3500

206-PR-C

FLOW CAPACITY (SEE 206-PG IN MAIN VALVE SECTION FOR OTHER VALVE DATA)

Size (Inches)	3"	4"	6"	8"	10"	12"	16"	18"	20"
Size (mm)	80 mm	100 mm	150 mm	200 mm	250 mm	300 mm	400 mm	450 mm	500 mm
Minimum (USGPM) Flat Diaphragm	1	2	4	20	40	-	-	-	-
Minimum (USGPM) Rolling Diaphragm	-	-	-	1	1	3	3	3	3
Minimum (L/s) Flat Diaphragm	0.06	0.13	0.25	1.3	2.5	-	-	-	-
Minimum (L/s) Rolling Diaphragm	-	-	-	0.06	0.06	0.2	0.2	0.2	0.2
Maximum Continuous (USGPM)	300	580	1025	2300	4100	6400	9230	16500	16500
Maximum Continuous (L/s)	19	37	65	145	260	404	582	1040	1040

206-PR-C

FLOW CAPACITY (SEE 206-PG IN MAIN VALVE SECTION FOR OTHER VALVE DATA)

Size (Inches)	24 x 16"	24 x 20"	28"	30"	32"	36"	40"	48"
Size (mm)	600 x 400 mm	600 x 500 mm	700 mm	750 mm	800 mm	900 mm	1000 mm	1200 mm
Minimum (USGPM) Rolling Diaphragm	3	3	10	10	10	10	20	20
Minimum (L/s) Rolling Diaphragm	0.2	0.2	0.6	0.6	0.6	0.6	1.3	1.3
Maximum Continuous (USGPM)	16500	21700	33600	33650	33700	33800	55475	55475
Maximum Continuous (L/s)	1041	1370	2120	2123	2126	2132	3500	3500

MODELS 106-PR-R / 206-PR-R

Pressure Reducing and Pressure Sustaining Valve

KEY FEATURES

- Excellent low flow stability
- Ensures minimum upstream pressure
- Easily and precisely set downstream pressure

PRODUCT OVERVIEW

The 106-PR-R and 206-PR-R pressure reducing and pressure sustaining valves are based on the 106-PG or 206-PG main valve with the addition of the sustaining pilot 81-RP and pressure reducing 160 PR.

Provided the upstream pressure setting is satisfied, the 81-RP pilot is kept open, permitting the valve to be controlled by the 160 pilot. The 160 pilot senses downstream pressure and under flowing conditions, it reacts to small changes in pressure to control the valve position by modulating the pressure above the diaphragm.

Should high demand cause the inlet pressure to fall to the 81-RP pilot setting, the upstream pressure has priority and the valve will modulate to prevent the upstream pressures from dropping below the set-point.



When the valve is modulating to sustain upstream pressure above the minimum 81-RP pilot set-point, the downstream 160 PR pilot may try to open the valve to maintain its set-point, but upstream has priority and downstream pressures will fall below expectations.

In typical applications, the standard port model 206-PR-R is often the best selection.

TYPICAL APPLICATION

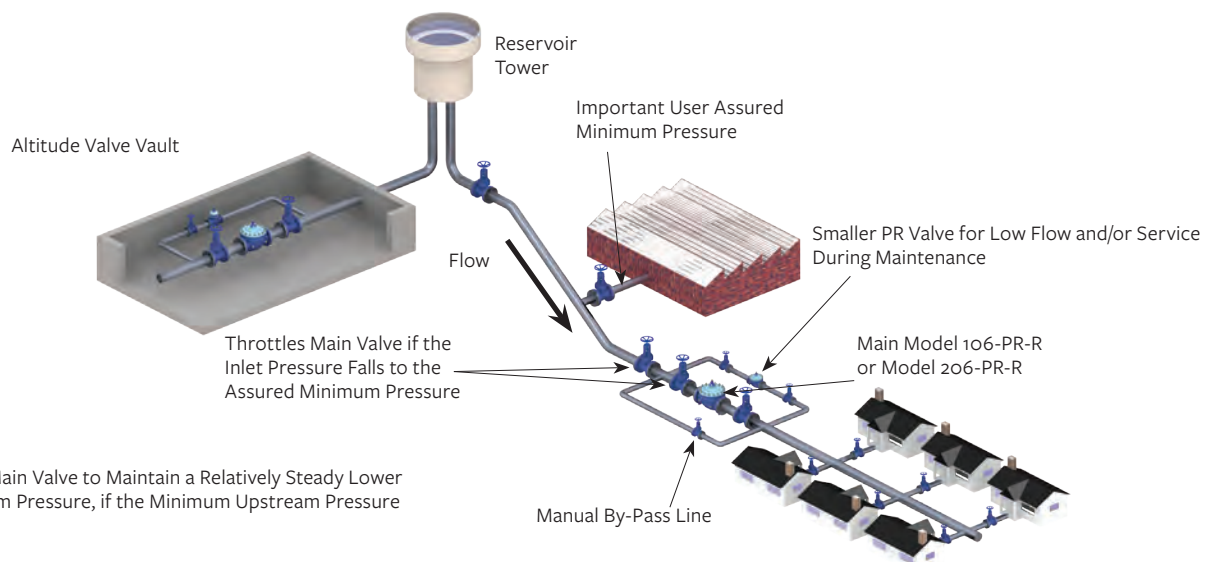

Throttles Main Valve to Maintain a Relatively Steady Lower Downstream Pressure, if the Minimum Upstream Pressure is Satisfied.

MODELS 106-PR-R / 206-PR-R

Pressure Reducing and Pressure Sustaining Valve

SCHEMATIC DRAWING

NO.	PART
1	Main Valve - 106-PG or 206-PG
2	Isolation Valves - Standard 4" / 100 mm and Larger
3	Strainer - Standard 4" / 100 mm and Larger
4	Model 26 Flow Stabilizer / Opening Speed Control Standard on Valves 8" / 200 mm 106, 10" / 250 mm 206 and Smaller
5	Fixed Restriction
6	Isolation Valves - Standard 4" / 100 mm and Larger
7	Model 160 PR Pilot Specify for 5 to 50 psi / 0.35 to 3.5 bar, 10 to 80 psi / 0.70 to 5.5 bar, 20 to 200 psi / 1.38 to 13.8 bar, 100 to 300 psi / 6.9 to 20.7 bar.
8	Isolation Valve - Standard All Sizes
9	Model 81-RP Pilot - specify for 5 to 50 psi / 0.35 to 3.5 bar; 10 to 80 psi / 0.7 to 5.5 bar; 100 to 300 psi / 6.9 to 20.7 bar; 20 to 200 psi / 1.38 to 13.8 bar Standard.

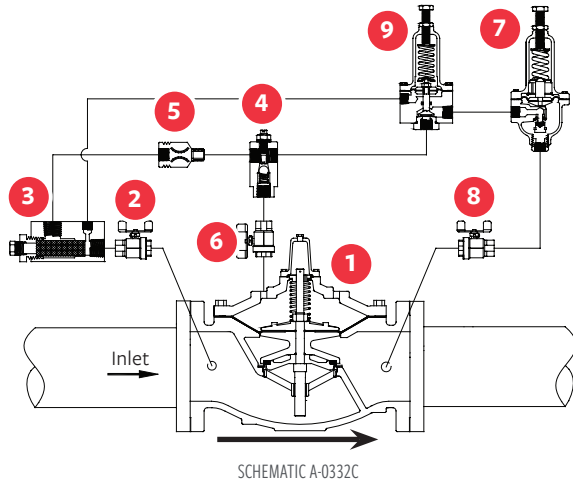

STANDARD MATERIALS

Standard materials for pilot system components are:

- ASTM B62 bronze or ASTM B16 brass
- AISI 303/316 stainless trim

SELECTION SUMMARY

1. Select the valve series and size with sufficient capacity
2. Check the operating flow against valve minimum.
3. If the outlet pressure is less than 35% of the inlet pressure, check for cavitation.
4. Ensure that the flange rating exceeds the maximum operating pressure.

ORDERING INSTRUCTIONS

Refer to page 244 for the order form and ordering instructions.

Additionally, include the following information for this product:

1. Single chamber (106) or (206)
2. Pilot ranges

MODELS 106-PR-R / 206-PR-R

Pressure Reducing and Pressure Sustaining Valve

106-PR-R

FLOW CAPACITY (SEE 106-PG IN MAIN VALVE SECTION FOR OTHER VALVE DATA)

Size (Inches)	½"	¾"	1"	1 ¼"	1 ½"	2"	2 ½"	3"	4"
Size (mm)	15 mm	19 mm	25 mm	32 mm	40 mm	50 mm	65 mm	80 mm	100 mm
Minimum (USGPM) Flat Diaphragm	1	1	1	1	1	1	1	2	4
Minimum (L/s) Flat Diaphragm	0.06	0.06	0.06	0.06	0.06	0.06	0.06	0.13	0.25
Maximum Continuous (USGPM)	12	19	49	93	125	210	300	460	800
Maximum Continuous (L/s)	0.8	1	3	6	8	13	19	29	50

106-PR-R

FLOW CAPACITY (SEE 106-PG IN MAIN VALVE SECTION FOR OTHER VALVE DATA)

Size (Inches)	6"	8"	10"	12"	14"	16"	20"	24"	36"
Size (mm)	150 mm	200 mm	250 mm	300 mm	350 mm	400 mm	500 mm	600 mm	900 mm
Minimum (USGPM) Flat Diaphragm	20	40	-	-	-	-	-	-	-
Minimum (USGPM) Rolling Diaphragm	1	1	3	3	3	3	10	10	20
Minimum (L/s) Flat Diaphragm	1.3	2.5	-	-	-	-	-	-	-
Minimum (L/s) Rolling Diaphragm	0.06	0.06	0.2	0.2	0.2	0.2	0.6	0.6	1.3
Maximum Continuous (USGPM)	1800	3100	4900	7000	8500	11000	17500	25800	55475
Maximum Continuous (L/s)	114	196	309	442	536	694	1104	1628	3500

206-PR-R

FLOW CAPACITY (SEE 206-PG IN MAIN VALVE SECTION FOR OTHER VALVE DATA)

Size (Inches)	3"	4"	6"	8"	10"	12"	16"	18"	20"
Size (mm)	80 mm	100 mm	150 mm	200 mm	250 mm	300 mm	400 mm	450 mm	500 mm
Minimum (USGPM) Flat Diaphragm	1	2	4	20	40	-	-	-	-
Minimum (USGPM) Rolling Diaphragm	-	-	-	1	1	3	3	3	3
Minimum (L/s) Flat Diaphragm	0.06	0.13	0.25	1.3	2.5	-	-	-	-
Minimum (L/s) Rolling Diaphragm	-	-	-	0.06	0.06	0.2	0.2	0.2	0.2
Maximum Continuous (USGPM)	300	580	1025	2300	4100	6400	9230	16500	16500
Maximum Continuous (L/s)	19	37	65	145	260	404	582	1040	1040

206-PR-R

FLOW CAPACITY (SEE 206-PG IN MAIN VALVE SECTION FOR OTHER VALVE DATA)

Size (Inches)	24 x 16"	24 x 20"	28"	30"	32"	36"	40"	48"
Size (mm)	600 mm	600 mm	700 mm	750 mm	800 mm	900 mm	1000 mm	1200 mm
Minimum (USGPM) Rolling Diaphragm	3	3	10	10	10	10	20	20
Minimum (L/s) Rolling Diaphragm	0.2	0.2	0.6	0.6	0.6	0.6	1.3	1.3
Maximum Continuous (USGPM)	16500	21700	33600	33650	33700	33800	55475	55475
Maximum Continuous (L/s)	1040	1370	2120	2123	2126	2132	3500	3500

MODELS 106-PR-S / 206-PR-S

Pressure Reducing Valve with Downstream Surge Protection

KEY FEATURES

- Excellent low flow stability
- Automatically reduces downstream surges during sudden demand reductions
- Easily and precisely set downstream pressure

PRODUCT OVERVIEW

The 106-PR-S and 206-PR-S pressure reducing valves with downstream surge control are based on the 106-PG or 206-PG main valve.

Pressure reducing pilot valve senses the downstream pressure through a connection at the valve outlet. Under flowing conditions, the pilot reacts to small changes in pressure to control the valve position by modulating the pressure above the diaphragm. The downstream pressure is maintained relatively steady at the pilot set-point.

The surge pilot senses the downstream pressure. If the pressure rises above the pressure reducing pilot setting and reaches the surge pilot setting, the surge pilot opens in order to close the main valve rapidly.



TYPICAL APPLICATION

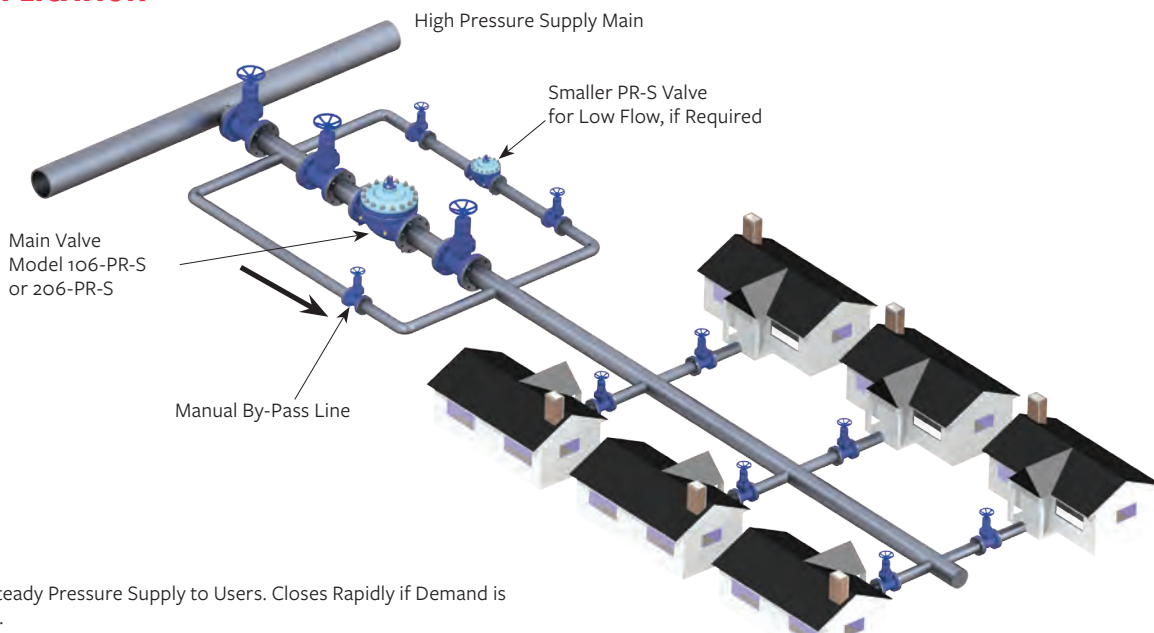

Lower Relatively Steady Pressure Supply to Users. Closes Rapidly if Demand is Suddenly Reduced.

MODELS 106-PR-S / 206-PR-S

Pressure Reducing Valve with Downstream Surge Protection

SCHEMATIC DRAWING

NO.	PART
1	Main Valve - 106-PG or 206-PG
2	Isolation Valve - Standard 4" / 100 mm and Larger
3	Strainer - Standard 4" / 100 mm and Larger
4*	Model 26 Flow Stabilizer / Opening Speed Control Standard on Valves 8" / 200 mm 106, 10" / 250 mm 206 and Smaller
5	Fixed Restriction
6	Isolation Valve - Standard 4" / 100 mm and Larger
7	Model 160 Pilot
7	Specify for 5 to 50 psi / 0.35 to 3.5 bar, 10 to 80 psi / 0.70 to 5.5 bar, 20 to 200 psi / 1.38 to 13.8 bar, 100 to 300 psi / 6.9 to 20.7 bar.
8	Isolation Valve - Standard All Sizes
9	Model 81 RP Surge Pilot - Standard Spring 20 to 200 psi / 1.38 to 13.8 bar - Specify for 5 to 50 psi / 0.35 to 3.5 bar, 10 to 80 psi / 0.7 to 5.5 bar, 100 to 300 psi / 6.9 to 20.7 bar.

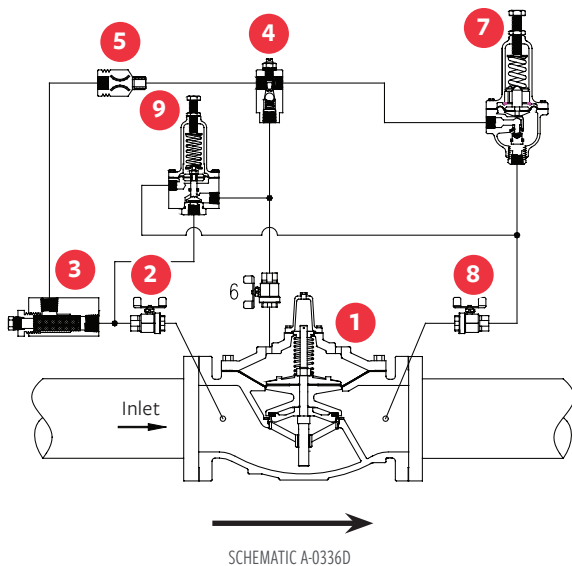

STANDARD MATERIALS

Standard materials for pilot system components are:

- ASTM B62 bronze or ASTM B16 brass
- AISI 303/316 stainless steel trim
- Buna-N / EPDM diaphragm and seals

SELECTION SUMMARY

1. Select the valve series and size with sufficient capacity
2. Check the operating flow against valve minimum.
3. Surge pilot typically set 5 psi / 0.35 bar higher than reducing pilot.
4. If the outlet pressure is less than 35% of the inlet pressure, check for cavitation.
5. Ensure that the flange rating exceeds the maximum operating pressure.

ORDERING INSTRUCTIONS

Refer to page 244 for the order form and ordering instructions.

Additionally, include the following information for this product:

1. Single chamber (106) or (206)
2. Pilot ranges

MODELS 106-PR-S / 206-PR-S

Pressure Reducing Valve with Downstream Surge Protection

106-PR-S

FLOW CAPACITY (SEE 106-PG IN MAIN VALVE SECTION FOR OTHER VALVE DATA)

Size (Inches)	½"	¾"	1"	1 ¼"	1 ½"	2"	2 ½"	3"	4"
Size (mm)	15 mm	19 mm	25 mm	32 mm	40 mm	50 mm	65 mm	80 mm	100 mm
Minimum (USGPM) Flat Diaphragm	1	1	1	1	1	1	1	2	4
Minimum (L/s) Flat Diaphragm	0.06	0.06	0.06	0.06	0.06	0.06	0.06	0.13	0.25
Maximum Continuous (USGPM)	12	19	49	93	125	210	300	460	800
Maximum Continuous (L/s)	0.8	1	3	6	8	13	19	29	50

106-PR-S

FLOW CAPACITY (SEE 106-PG IN MAIN VALVE SECTION FOR OTHER VALVE DATA)

Size (Inches)	6"	8"	10"	12"	14"	16"	20"	24"	36"
Size (mm)	150 mm	200 mm	250 mm	300 mm	350 mm	400 mm	500 mm	600 mm	900 mm
Minimum (USGPM) Flat Diaphragm	20	40	-	-	-	-	-	-	-
Minimum (USGPM) Rolling Diaphragm	1	1	3	3	3	3	10	10	20
Minimum (L/s) Flat Diaphragm	1.3	2.5	-	-	-	-	-	-	-
Minimum (L/s) Rolling Diaphragm	0.06	0.06	0.2	0.2	0.2	0.2	0.6	0.6	1.3
Maximum Continuous (USGPM)	1800	3100	4900	7000	8500	11000	17500	25800	55475
Maximum Continuous (L/s)	114	196	309	442	536	694	1104	1628	3500

206-PR-S

FLOW CAPACITY (SEE 206-PG IN MAIN VALVE SECTION FOR OTHER VALVE DATA)

Size (Inches)	3"	4"	6"	8"	10"	12"	16"	18"	20"
Size (mm)	80 mm	100 mm	150 mm	200 mm	250 mm	300 mm	400 mm	450 mm	500 mm
Minimum (USGPM) Flat Diaphragm	1	2	4	20	40	-	-	-	-
Minimum (USGPM) Rolling Diaphragm	-	-	-	1	1	3	3	3	3
Minimum (L/s) Flat Diaphragm	0.06	0.13	0.25	1.3	2.5	-	-	-	-
Minimum (L/s) Rolling Diaphragm	-	-	-	0.06	0.06	0.2	0.2	0.2	0.2
Maximum Continuous (USGPM)	300	580	1025	2300	4100	6400	9230	16500	16500
Maximum Continuous (L/s)	19	37	65	145	259	404	582	1041	1041

206-PR-S

FLOW CAPACITY (SEE 206-PG IN MAIN VALVE SECTION FOR OTHER VALVE DATA)

Size (Inches)	24 x 16"	24 x 20"	28"	30"	32"	36"	40"	48"
Size (mm)	600 mm	600 mm	700 mm	750 mm	800 mm	900 mm	1000 mm	1200 mm
Minimum (USGPM) Rolling Diaphragm	3	3	10	10	10	10	20	20
Minimum (L/s) Rolling Diaphragm	0.2	0.2	0.6	0.6	0.6	0.6	1.3	1.3
Maximum Continuous (USGPM)	16500	21700	33600	33650	33700	33800	55475	55475
Maximum Continuous (L/s)	1040	1370	2120	2123	2126	2132	3500	3500

MODELS 106-PR-SC / 206-PR-SC

Pressure Reducing Valve with Solenoid Shut-Off

KEY FEATURES

- Excellent low flow stability
- Fast-acting solenoid override
- Operates as normally open or closed
- Easily and precisely set downstream pressure

PRODUCT OVERVIEW

The 106-PR-SC and 206-PR-SC pressure reducing valves with solenoid shut-off are based on the 106-PG or 206-PG main valve.

The pilot valve senses the downstream pressure through a connection at the valve outlet. Under flowing conditions, the pilot reacts to small changes in pressure to control the valve position by modulating the pressure above the diaphragm. The downstream pressure is maintained relatively steady at the pilot set-point.

The solenoid shut-off / override interrupts the PR function to close off the main valve. The valve is available as either normally open where the solenoid is energized to close the main valve or as normally closed where the solenoid is de-energized to close the main valve.



TYPICAL APPLICATION

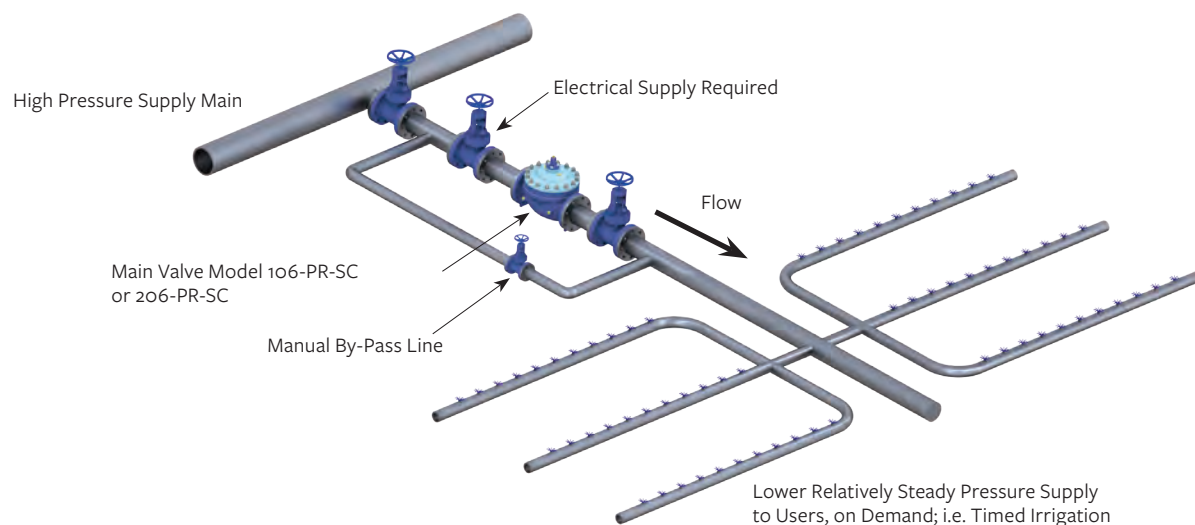

MODELS 106-PR-SC / 206-PR-SC

Pressure Reducing Valve with Solenoid Shut-Off

SCHEMATIC DRAWING

NO.	PART
1	Main Valve - 106-PG or 206-PG
2	Isolation Valves - Standard 4" / 100 mm and Larger
3	Strainer - Standard 4" / 100 mm and Larger
4*	Model 26 Flow Stabilizer / Opening Speed Control Standard on Valves 8" / 200 mm 106, 10" / 250 mm 206 and Smaller
5	Fixed Restriction
6	Isolation Valves - Standard 4" / 100 mm and Larger
7	Model 160 Pilot Specify for 5 to 50 psi / 0.35 to 3.5 bar, 10 to 80 psi / 0.70 to 5.5 bar, 20 to 200 psi / 1.38 to 13.8 bar, 100 to 300 psi / 6.9 to 20.7 bar.
8	Isolation Valve - Standard All Sizes
9	Closing Speed Control - Model 852-B
10	Solenoid Valve - 2 Way

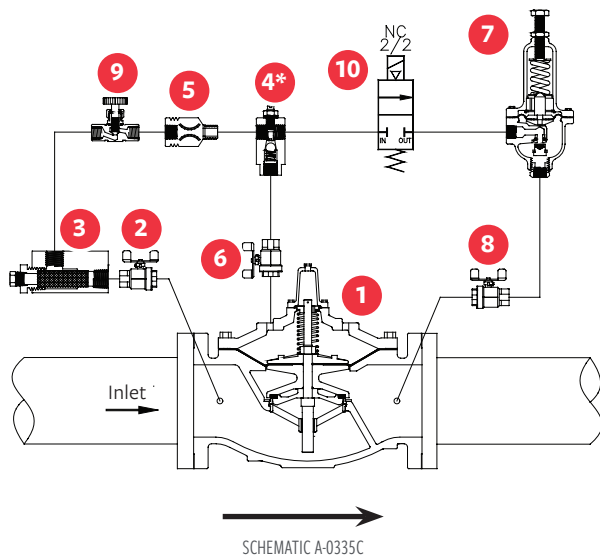

STANDARD MATERIALS

Standard materials for pilot system components are:

ASTM B62 bronze or ASTM B16 brass

AISI 303/316 stainless steel trim

Buna-N / EPDM diaphragm and seals

SELECTION SUMMARY

1. Select the valve series and size with sufficient capacity.
2. Check the operating flow against valve minimum.
3. If the outlet pressure is less than 35% of the inlet pressure, check for cavitation.
4. Determine whether operation is energized or de-energized to close the main valve.
5. Select the voltage (120 VAC standard) for solenoid and advise maximum operating differential pressure.
6. Ensure that the flange rating exceeds the maximum operating pressure.

ORDERING INSTRUCTIONS

Refer to page 244 for the order form and ordering instructions.

Additionally, include the following information for this product:

1. Single chamber (106) or (206)
2. Pilot range

MODELS 106-PR-SC / 206-PR-SC

Pressure Reducing Valve with Solenoid Shut-Off

106-PR-SC

FLOW CAPACITY (SEE 106-PG IN MAIN VALVE SECTION FOR OTHER VALVE DATA)

Size (Inches)	½"	¾"	1"	1 ¼"	1 ½"	2"	2 ½"	3"	4"
Size (mm)	15 mm	19 mm	25 mm	32 mm	40 mm	50 mm	65 mm	80 mm	100 mm
Minimum (USGPM) Flat Diaphragm	1	1	1	1	1	1	1	2	4
Minimum (L/s) Flat Diaphragm	0.06	0.06	0.06	0.06	0.06	0.06	0.06	0.13	0.25
Maximum Continuous (USGPM)	12	19	49	93	125	210	300	460	800
Maximum Continuous (L/s)	0.8	1	3	6	8	13	19	29	50

106-PR-SC

FLOW CAPACITY (SEE 106-PG IN MAIN VALVE SECTION FOR OTHER VALVE DATA)

Size (Inches)	6"	8"	10"	12"	14"	16"	20"	24"	36"
Size (mm)	150 mm	200 mm	250 mm	300 mm	350 mm	400 mm	500 mm	600 mm	900 mm
Minimum (USGPM) Flat Diaphragm	20	40	-	-	-	-	-	-	-
Minimum (USGPM) Rolling Diaphragm	1	1	3	3	3	3	10	10	20
Minimum (L/s) Flat Diaphragm	1.3	2.5	-	-	-	-	-	-	-
Minimum (L/s) Rolling Diaphragm	0.06	0.06	0.2	0.2	0.2	0.2	0.6	0.6	1.3
Maximum Continuous (USGPM)	1800	3100	4900	7000	8500	11000	17500	25800	55475
Maximum Continuous (L/s)	114	196	309	442	536	694	1104	1628	3500

206-PR-SC

FLOW CAPACITY (SEE 206-PG IN MAIN VALVE SECTION FOR OTHER VALVE DATA)

Size (Inches)	3"	4"	6"	8"	10"	12"	16"	18"	20"
Size (mm)	80 mm	100 mm	150 mm	200 mm	250 mm	300 mm	400 mm	450 mm	500 mm
Minimum (USGPM) Flat Diaphragm	1	2	4	20	40	-	-	-	-
Minimum (USGPM) Rolling Diaphragm	-	-	-	1	1	3	3	3	3
Minimum (L/s) Flat Diaphragm	0.06	0.13	0.25	1.3	2.5	-	-	-	-
Minimum (L/s) Rolling Diaphragm	-	-	-	0.06	0.06	0.2	0.2	0.2	0.2
Maximum Continuous (USGPM)	300	580	1025	2300	4100	6400	9230	16500	16500
Maximum Continuous (L/s)	19	37	65	145	260	404	582	1040	1040

206-PR-SC

FLOW CAPACITY (SEE 206-PG IN MAIN VALVE SECTION FOR OTHER VALVE DATA)

Size (Inches)	24 x 16"	24 x 20"	28"	30"	32"	36"	40"	48"
Size (mm)	600 x 400 mm	600 x 500 mm	700 mm	750 mm	800 mm	900 mm	1000 mm	1200 mm
Minimum (USGPM) Rolling Diaphragm	3	3	10	10	10	10	20	20
Minimum (L/s) Rolling Diaphragm	0.2	0.2	0.6	0.6	0.6	0.6	1.3	1.3
Maximum Continuous (USGPM)	16500	21700	33600	33650	33700	33800	55475	55475
Maximum Continuous (L/s)	1040	1370	2120	2123	2126	2132	3500	3500

MODEL 106-2PR-630 / 206-2PR-630

Pressure Management Valve

KEY FEATURES

- Valve switches between high and low pressure pilots based on flow rate.
- Pressure reducing pilots independently adjustable to suit the desired downstream pressure.
- Orifice is upstream of control valve so downstream pressure setting is unaffected by flow.
- Standard components completely submersible - no electrical power required.
- Simple field retrofit is possible using the paddle style orifice plate.



PRODUCT OVERVIEW

The Singer® 106/206-2PR-630 Pressure Management Valve is a simple package to save water loss and money. It meets system needs by providing higher pressure when called for 24/7 and reduced pressure to save water leakage (and money) at all other times.

An orifice with a low pressure drop 1.0 psi, (0.07 Bar) is installed upstream of a standard pressure reducing valve fitted with an extra pressure reducing pilot and a sensitive differential pilot

which switches between 2 pressure reducing pilots to suit the system flow demand. High flow demand or fire flow will cause the differential pilot to automatically switch control from the low pressure to the higher pressure pilot. The action is then reversed when flow demand falls below the differential pilot set point. valve position by modulating the pressure above the diaphragm. The downstream pressure is maintained relatively steady at the pilot set-point.

TYPICAL APPLICATION

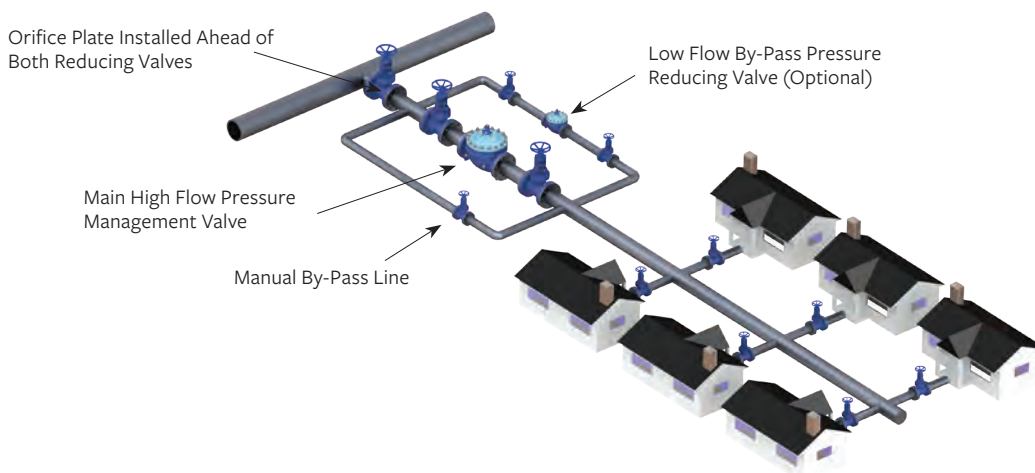

MODEL 106-2PR-630 / 206-2PR-630

Pressure Management Valve

SCHEMATIC DRAWING

NO.	PART
1	Main Valve - 106-PG or 206-PG
2	Isolation Valve
3	Strainer - 40 Mesh
4*	Model 26 Flow Stabilizer / Opening Speed Control
5	Closing Speed Control
6	Fixed Restriction
7	Differential Pilot – Normal Closed – Model 630-RPD
8	Pressure Reducing Pilot – Model 160 Higher Setting
9	Pressure Reducing Pilot – Model 160 Lower Setting
10	Orifice Plate – Paddle style standard – Optional with Housing

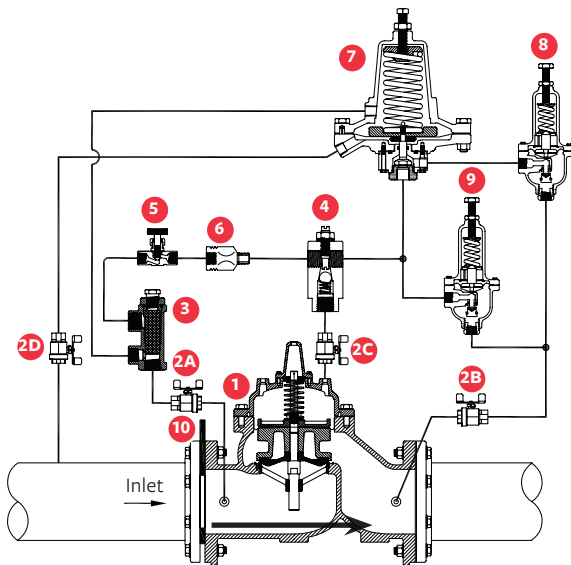

SCHEMATIC A-10496A2

BENEFITS

- Substantially reduces water loss (non-revenue water) due to leakage.
- Decreases downstream pipe bursts and associated repair costs.
- Allows constant reliable pressure to users, minimizing over pressure at off peak (flow) periods.

SELECTION SUMMARY

1. Sizes: 4" - 12" (100 mm - 300 mm) for other sizes please consult factory.
2. Pressures: Minimum pressure of 29 psi (2 Bar) at valve inlet, (Consult factory for lower pressure applications).
3. Differential required across Orifice plate: 1.45 - 2 psi (0.1 - 0.14 Bar).
4. Fire Flow: if fire flow is greater than twice the normal high flow rate set point, please consult factory.

ORDERING INSTRUCTIONS

Refer to page 244 for the order form and ordering instructions.

Additionally, include the following information for this product:

1. Single chamber (106) or (206)
2. Pilot range



RELIEF / SUSTAINING / SURGE

You can count on our valves to do exactly what they are designed to do. Relieve pressure. Sustain differential pressure. Anticipate surges. Plus more. Whatever their purpose, our valves give you the protection your application needs. What a relief.

MODELS 106-RPS / 206-RPS

Pressure Relief Valve

KEY FEATURES

- Limits system pressure by relieving excess flow
- Quick opening relief
- Easily adjustable pressure setting

PRODUCT OVERVIEW

The 106-RPS and 206-RPS pressure relief valves are based on the 106-PG and 206-PG main valves.

The 81-RP pilot senses the upstream pressure through a connection to the valve inlet. The valve and pilot remain closed until the inlet pressure exceeds the pilot setting. The valve opens rapidly to relieve damaging overpressure and closes smoothly at an adjustable speed, when the pressure returns below the set-point. The upstream pressure is limited to the pilot set-point.

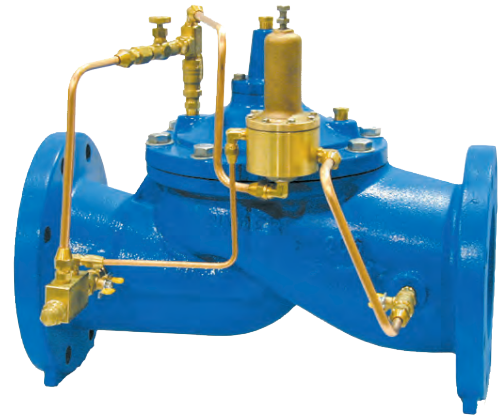

TYPICAL APPLICATION

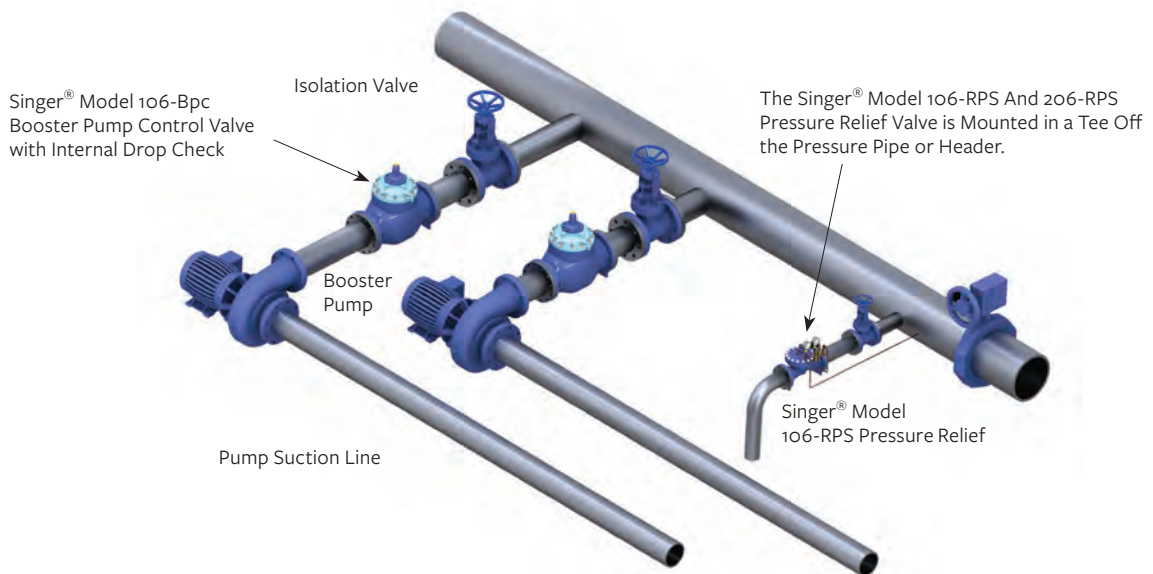

MODELS 106-RPS / 206-RPS

Pressure Relief Valve

SCHEMATIC DRAWING

NO.	PART
1	Main Valve - 106-PG or 206-PG
2	Isolation Valve - Standard 4" / 100 mm and Larger
3	Strainer - Standard 4" / 100 mm and Larger
4	Fixed Restriction - 1/8" / 3.2 mm
5	Model 852-B Closing Speed Control
6	Model 81-RP Pilot Specify for 5 to 50 psi / 0.35 to 3.5 bar, 10 to 80 psi / 0.70 to 5.5 bar, 20 to 200 psi / 1.38 to 13.8 bar, 100 to 300 psi / 6.9 to 20.7 bar.
7	Isolation Valve - Standard 4" / 100 mm and Larger
8	Isolation Valve - Standard All Sizes

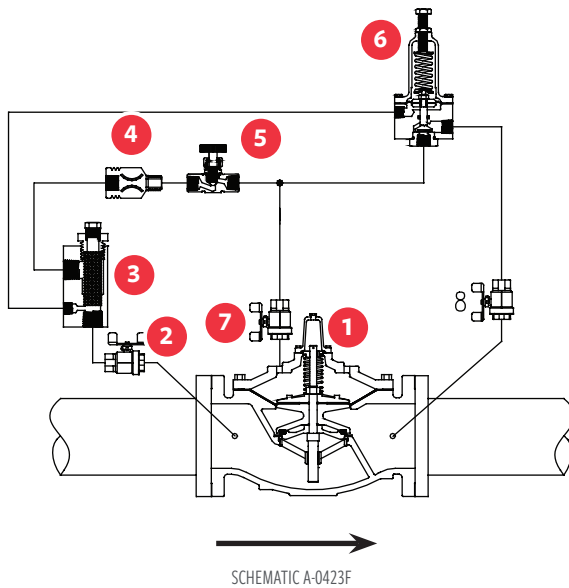

STANDARD MATERIALS

Standard materials for pilot system components are:

- ASTM B62 bronze or ASTM B16 brass
- AISI 303 / 316 stainless steel trim
- Buna-N / EPDM diaphragm and seals

SELECTION SUMMARY

1. Select the valve with sufficient capacity using the available pressure drop across the valve.
2. Usually operating in the momentary "M" service range.
3. For extended or continuous relief applications, use model 106-RPS-AC: Pressure Relief with Anti-Cavitation Cages.
4. Ensure that the maximum working pressure rating for the valve and for the flanges exceeds the maximum operating pressure.
5. Select a standard globe style body or the optional angle style body.

ORDERING INSTRUCTIONS

Refer to page 244 for the order form and ordering instructions.

Additionally, include the following information for this product:

1. Single chamber (106) or (206)
2. Relief pressure range
3. Outlet pressure

MODELS 106-RPS / 206-RPS

Pressure Relief Valve

FLOW CAPACITY – RELIEF

106-RPS

FLOW CAPACITY 45 FT/S OR 14 M/S
(SEE 106-PG IN MAIN VALVE SECTION FOR OTHER VALVE DATA)

Size (Inches)	½"	¾"	1"	1 ¼"	1 ½"	2"	2 ½"	3"	4"
Size (mm)	15 mm	19 mm	25 mm	32 mm	40 mm	50 mm	65 mm	80 mm	100 mm
Momentary (USGPM)	28	43	110	170	250	470	670	1030	1800
Momentary (L/s)	2	3	7	11	16	30	42	65	114

106-RPS

FLOW CAPACITY 45 FT/S OR 14 M/S
(SEE 106-PG IN MAIN VALVE SECTION FOR OTHER VALVE DATA)

Size (Inches)	6"	8"	10"	12"	14"	16"	20"	24"	36"
Size (mm)	150 mm	200 mm	250 mm	300 mm	350 mm	400 mm	500 mm	600 mm	900 mm
Momentary (USGPM)	4000	7000	11000	16000	19000	25000	39000	56200	124700
Momentary (L/s)	252	442	694	1009	1199	1577	2461	3546	7868

206-RPS

FLOW CAPACITY 45 FT/S OR 14 M/S
(SEE 206-PG IN MAIN VALVE SECTION FOR OTHER VALVE DATA)

Size (Inches)	3"	4"	6"	8"	10"	12"	16"	18"	20"
Size (mm)	80 mm	100 mm	150 mm	200 mm	250 mm	300 mm	400 mm	450 mm	500 mm
Momentary (USGPM)	564	1236	2160	4800	8400	13200	19200	30000	30050
Momentary (L/s)	36	78	136	303	530	833	1211	1893	1896

206-RPS

FLOW CAPACITY 45 FT/S OR 14 M/S
(SEE 206-PG IN MAIN VALVE SECTION FOR OTHER VALVE DATA)

Size (Inches)	24 x 16"	24 x 20"	28"	30"	32"	36"	40"	48"
Size (mm)	600 x 400 mm	600 x 500 mm	700 mm	750 mm	800 mm	900 mm	1000 mm	1200 mm
Momentary (USGPM)	30100	39000	67440	67490	67540	67640	62000	124700
Momentary (L/s)	1899	2461	4255	4258	4261	4268	3912	7868

MODELS 106-RPS / 206-RPS

Pressure Sustaining Valves

KEY FEATURES

- Ensures minimum upstream pressure for critical use
- Easily adjustable pressure setting
- Closes if inlet pressure drops below set-point

PRODUCT OVERVIEW

The 106-RPS and 206-RPS pressure sustaining valves are based on the model 106-PG or 206-PG main valve.

The 81-RP pilot senses the upstream pressure through a connection to the valve inlet. The valve and pilot remain closed until the inlet pressure exceeds the pilot setting.

Under flowing conditions, the pilot reacts to small changes in pressure to control the valve position by modulating the pressure above the diaphragm.

Should the upstream pressure fall below the set-point, the valve will close or modulate to ensure that the set-point is maintained.

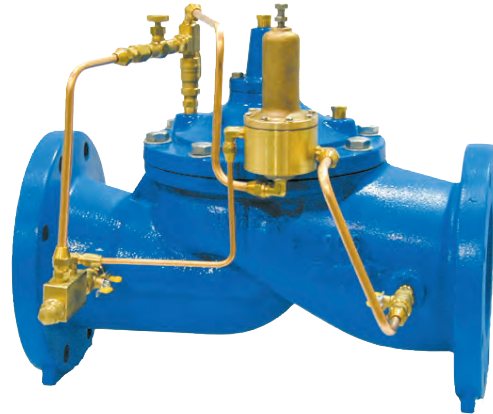

TYPICAL APPLICATION

The 106-RPS or 206-RPS valve prevents high demand in the residential area from dropping the pressure available to the critical user.

Valve modulates to assure minimum upstream pressure and if need be, closes tight.

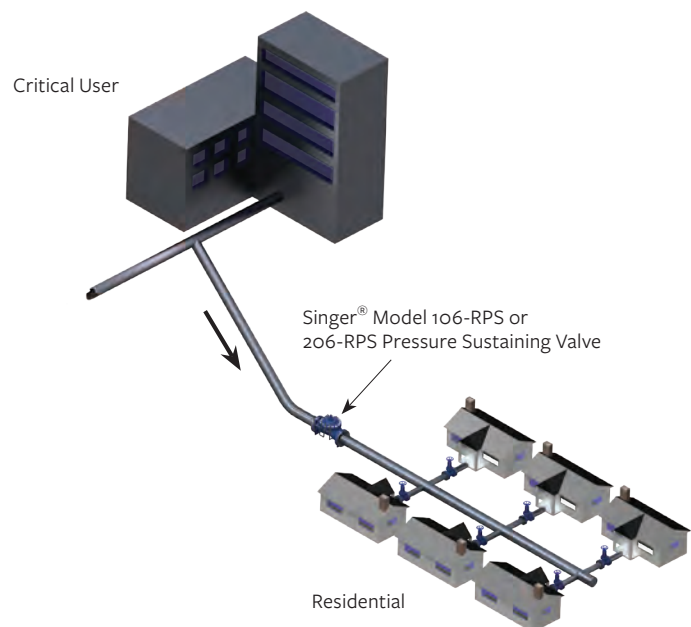

MODELS 106-RPS / 206-RPS

Pressure Sustaining Valves

SCHEMATIC DRAWING

NO.	PART
1	Main Valve - 106-PG or 206-PG
2	Isolation Valve - Standard 4" / 100 mm and Larger
3	Strainer - Standard 4" / 100 mm and Larger
4	Fixed Restriction- 1/8" / 3.2 mm
5	Model 852-B Closing Speed Control
6	Model 81-RP Pilot Specify for 5 to 50 psi / 0.35 to 3.5 bar, 10 to 80 psi / 0.70 to 5.5 bar, 20 to 200 psi / 1.38 to 13.8 bar, 100 to 300 psi / 6.9 to 20.7 bar.
7	Isolation Valve - Standard 4" / 100 mm and Larger
8	Isolation Valve - Standard All Sizes
9	Opening Speed Control, Optional

Note: SRD shown is available for 6" 106-PG and larger.

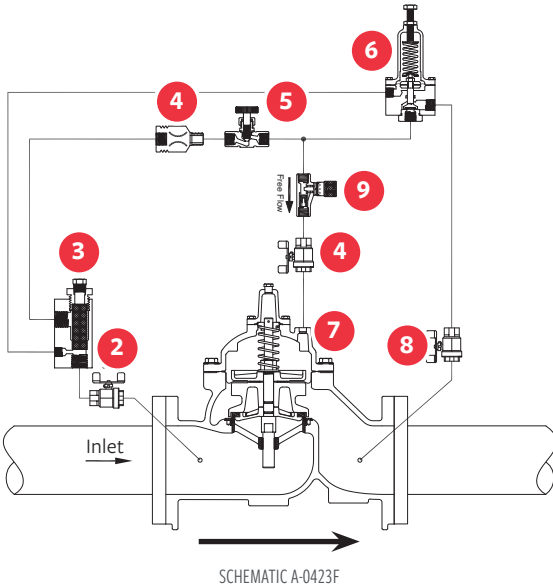

STANDARD MATERIALS

Standard materials for pilot system components are:

- ASTM B62 bronze or ASTM B16 brass
- AISI 303/316 stainless steel trim
- Buna-N / EPDM diaphragm and seals

SELECTION SUMMARY

1. Select the valve with sufficient capacity using the minimum available pressure drop across the valve.
2. Usually operating in the continuous "C" service range up to 20 ft/s / 6 m/s - see below and/or performance curves (see Technical & Sizing Information section, page 231).
3. If the outlet pressure is less than 35% of the inlet pressure and operating for extended periods, check for cavitation.
4. For sustaining applications with high pressure drops, a model 106-RPS-AC: Pressure Sustaining with anti-cavitation cages may be required. Refer to 106-AC section (page 78) and consult a Singer® representative.
5. Ensure that the maximum working pressure rating for the valve and for the flanges exceeds the maximum operating pressure.

ORDERING INSTRUCTIONS

Refer to page 244 for the order form and ordering instructions.

Additionally, include the following information for this product:

1. Single chamber (106) or (206)
2. Outlet pressure
3. Inlet pressure pilot range

MODELS 106-RPS / 206-RPS

Pressure Sustaining Valves

106-RPS-SUSTAINING

FLOW CAPACITY (SEE 106-PG IN MAIN VALVE SECTION FOR OTHER VALVE DATA)

Size (Inches)	½"	¾"	1"	1 ¼"	1 ½"	2"	2 ½"	3"	4"
Size (mm)	15 mm	19 mm	25 mm	32 mm	40 mm	50 mm	65 mm	80 mm	100 mm
Minimum (USGPM) Flat Diaphragm	1	1	1	1	1	5	5	5	10
Minimum (L/s) Flat Diaphragm	0.1	0.1	0.1	0.1	0.1	0.3	0.3	0.3	0.6
Maximum Continuous (USGPM)	12	19	49	93	125	210	300	460	800
Maximum Continuous (L/s)	0.8	1	3	6	8	13	19	29	50

106-RPS-SUSTAINING

FLOW CAPACITY (SEE 106-PG IN MAIN VALVE SECTION FOR OTHER VALVE DATA)

Size (Inches)	6"	8"	10"	12"	14"	16"	20"	24"	36"
Size (mm)	150 mm	200 mm	250 mm	300 mm	350 mm	400 mm	500 mm	600 mm	900 mm
Minimum (USGPM) Flat Diaphragm	20	40	-	-	-	-	-	-	-
Minimum (USGPM) Rolling Diaphragm	1	1	3	3	3	3	10	10	20
Minimum (L/s) Flat Diaphragm	1.3	2.5	-	-	-	-	-	-	-
Minimum (L/s) Rolling Diaphragm	0.1	0.1	0.2	0.2	0.2	0.2	0.6	0.6	1.3
Maximum Continuous (USGPM)	1800	3100	4900	7000	8500	11000	17500	25800	55475
Maximum Continuous (L/s)	114	196	309	442	536	694	1104	1628	3500

206-RPS-SUSTAINING

FLOW CAPACITY (SEE 206-PG IN MAIN VALVE SECTION FOR OTHER VALVE DATA)

Size (Inches)	3"	4"	6"	8"	10"	12"	16"	18"	20"
Size (mm)	80 mm	100 mm	150 mm	200 mm	250 mm	300 mm	400 mm	450 mm	500 mm
Minimum (USGPM) Flat Diaphragm	5	5	10	20	40	-	-	-	-
Minimum (USGPM) Rolling Diaphragm	-	-	-	-	-	3	3	3	3
Minimum (L/s) Flat Diaphragm	0.3	0.3	0.6	1.3	2.5	-	-	-	-
Minimum (L/s) Rolling Diaphragm	-	-	-	-	-	0.2	0.2	0.2	0.2
Maximum Continuous (USGPM)	300	580	1025	2300	4100	6400	9230	16500	16500
Maximum Continuous (L/s)	19	37	65	145	260	404	582	1040	1040

206-RPS-SUSTAINING

FLOW CAPACITY (SEE 206-PG IN MAIN VALVE SECTION FOR OTHER VALVE DATA)

Size (Inches)	24 x 16"	24 x 20"	28"	30"	32"	36"	40"	48"
Size (mm)	600 x 400 mm	600 x 500 mm	700 mm	750 mm	800 mm	900 mm	1000 mm	1200 mm
Minimum (USGPM) Rolling Diaphragm	3	3	10	10	10	10	20	20
Minimum (L/s) Rolling Diaphragm	0.2	0.2	0.6	0.6	0.6	0.6	1.3	1.3
Maximum Continuous (USGPM)	16500	21700	33600	33650	33700	33800	55475	55475
Maximum Continuous (L/s)	1041	1370	2120	2123	2126	2132	3500	3500

MODELS 106-RPS-D / 206-RPS-D

Pressure Differential Sustaining Valve

KEY FEATURES

- Maintains a minimum differential pressure
- Easily adjustable differential pressure setting
- Valve closes drip-tight when the pressure differential is less than the pilot setting

PRODUCT OVERVIEW

The 106-RPS-D and 206-RPS-D pressure differential sustaining valves are based on the 106-PG or 206-PG main valve.

The RPS-D uses the 81-RPD pilot valve and has two sensing connections. The valve and pilot remain closed until the difference between the two pressures exceeds the pilot setting.

Under flowing conditions, the pilot reacts to small changes in pressure to control the valve position by modulating the pressure above the diaphragm. The pilot setting establishes a differential pressure that is held relatively steady despite changes in system pressure or flow.

TYPICAL APPLICATION

PARALLEL APPLICATION

As the number of operating heat exchangers in the circuit vary, the Singer® RPS-D maintains a relatively steady differential for maximum chiller efficiency.

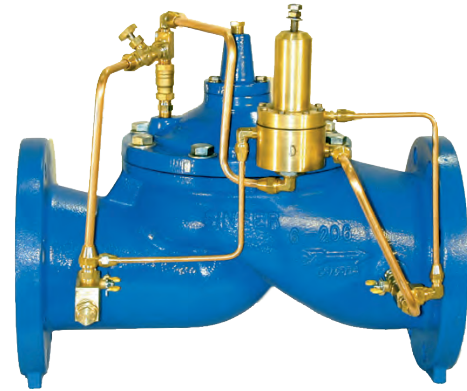

SERIES APPLICATION

In a booster pump application, the Singer® RPS-D ensures the pump operates near its best efficiency and without cavitation or overload, should the suction conditions vary.

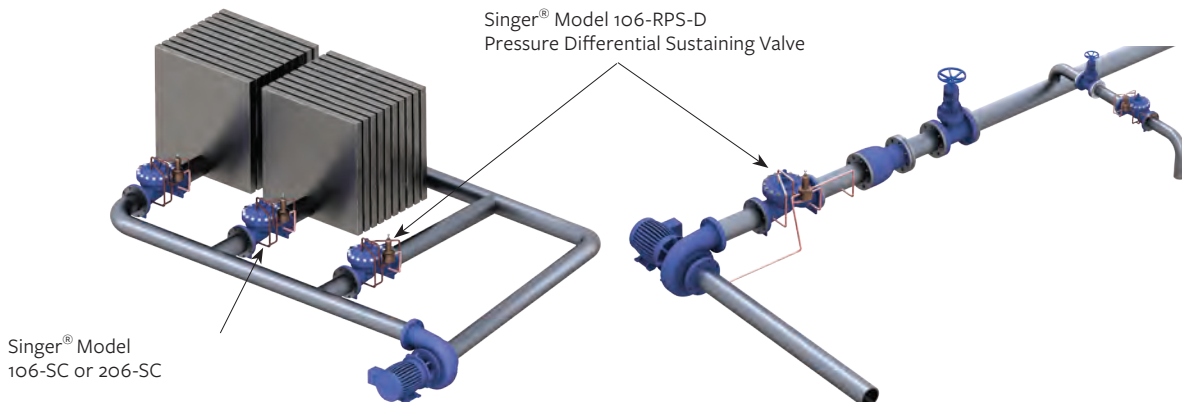

MODELS 106-RPS-D / 206-RPS-D

Pressure Differential Sustaining Valve

SCHEMATIC DRAWING

NO.	PART
1	Main Valve - 106-PG or 206-PG
2	Isolation Valve - Standard 4" / 100 mm and Larger
3	Strainer - Standard 4" / 100 mm and Larger
4	Fixed Restriction - 1/8" / 3.2 mm
5	Model 852-B Closing Speed Control
6	Model 81-RPD Pilot Specify for 5 to 50 psi / 0.35 to 3.5 bar, 10 to 80 psi / 0.70 to 5.5 bar, 20 to 200 psi / 1.38 to 13.8 bar, 100 to 300 psi / 6.9 to 20.7 bar.
7	Isolation Valve - Standard 4" / 100 mm and Larger
8	Isolation Valve - Standard All Sizes
9	Opening Speed Control (Optional)

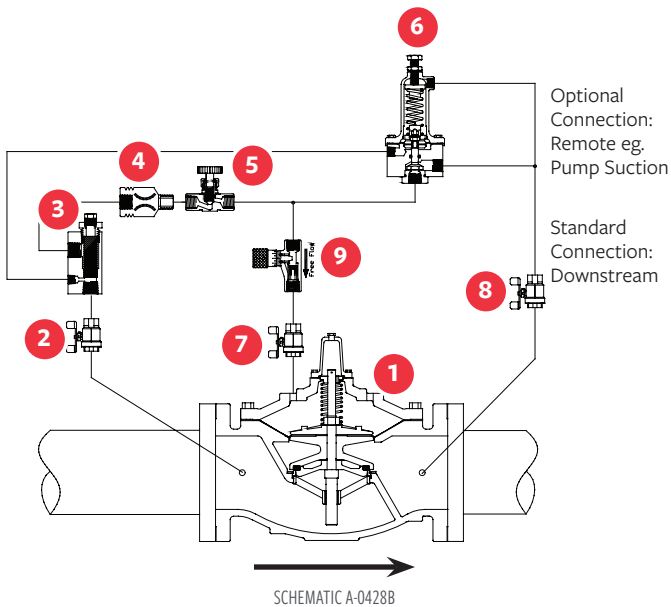

STANDARD MATERIALS

Standard materials for pilot system components are:

- ASTM B-62 bronze or ASTM B-16 brass
- AISI 316 stainless steel trim

SELECTION SUMMARY

1. Select the valve with sufficient capacity using the available pressure drop.
2. Usually operating in the continuous, "C", service range up to 20 ft/s / 6 m/s
3. If the outlet pressure is less than 35% of the inlet pressure, check for cavitation.
4. Ensure that the maximum working pressure rating of the valve and of the flange exceeds the maximum operating pressure.

ORDERING INSTRUCTIONS

Refer to page 244 for the order form and ordering instructions.

Additionally, include the following information for this product:

1. Single chamber (106) or (206)
2. Pilot range

MODELS 106-RPS-D / 206-RPS-D

Pressure Differential Sustaining Valve

106-RPS-D

FLOW CAPACITY (SEE 106-PG IN MAIN VALVE SECTION FOR OTHER VALVE DATA)

Size (Inches)	½"	¾"	1"	1 ¼"	1 ½"	2"	2 ½"	3"	4"
Size (mm)	15 mm	19 mm	25 mm	32 mm	40 mm	50 mm	65 mm	80 mm	100 mm
Minimum (USGPM) Flat Diaphragm	1	1	1	1	1	5	5	5	10
Minimum (L/s) Flat Diaphragm	0.1	0.1	0.1	0.1	0.1	0.3	0.3	0.3	0.6
Maximum Continuous (USGPM)	12	19	49	93	125	210	300	460	800
Maximum Continuous (L/s)	0.8	1	3	6	8	13	19	29	50

106-RPS-D

FLOW CAPACITY (SEE 106-PG IN MAIN VALVE SECTION FOR OTHER VALVE DATA)

Size (Inches)	6"	8"	10"	12"	14"	16"	20"	24"	36"
Size (mm)	150 mm	200 mm	250 mm	300 mm	350 mm	400 mm	500 mm	600 mm	900 mm
Minimum (USGPM) Flat Diaphragm	20	40	-	-	-	-	-	-	-
Minimum (USGPM) Rolling Diaphragm	1	1	3	3	3	3	10	10	20
Minimum (L/s) Flat Diaphragm	1.3	2.5	-	-	-	-	-	-	-
Minimum (L/s) Rolling Diaphragm	0.1	0.1	0.2	0.2	0.2	0.2	0.6	0.6	1.3
Maximum Continuous (USGPM)	1800	3100	4900	7000	8500	11000	17500	25800	55475
Maximum Continuous (L/s)	114	196	309	442	536	694	1104	1628	3500

206-RPS-D

FLOW CAPACITY (SEE 206-PG IN MAIN VALVE SECTION FOR OTHER VALVE DATA)

Size (Inches)	3"	4"	6"	8"	10"	12"	16"	18"	20"
Size (mm)	80 mm	100 mm	150 mm	200 mm	250 mm	300 mm	400 mm	450 mm	500 mm
Minimum (USGPM) Flat Diaphragm	5	5	10	20	40	-	-	-	-
Minimum (USGPM) Rolling Diaphragm	-	-	-	-	-	3	3	3	3
Minimum (L/s) Flat Diaphragm	0.3	0.3	0.6	1.3	2.5	-	-	-	-
Minimum (L/s) Rolling Diaphragm	-	-	-	-	-	0.2	0.2	0.2	0.2
Maximum Continuous (USGPM)	300	580	1025	2300	4100	6400	9230	16500	16500
Maximum Continuous (L/s)	19	37	65	145	260	404	582	1040	1040

206-RPS-D

FLOW CAPACITY (SEE 206-PG IN MAIN VALVE SECTION FOR OTHER VALVE DATA)

Size (Inches)	24 x 16"	24 x 20"	28"	30"	32"	36"	40"	48"
Size (mm)	600 x 400 mm	600 x 500 mm	700 mm	750 mm	800 mm	900 mm	1000 mm	1200 mm
Minimum (USGPM) Rolling Diaphragm	3	3	10	10	10	10	20	20
Minimum (L/s) Rolling Diaphragm	0.2	0.2	0.6	0.6	0.6	0.6	1.3	1.3
Maximum Continuous (USGPM)	16500	21700	33600	33650	33700	33800	55475	55475
Maximum Continuous (L/s)	1040	1370	2120	2123	2126	2132	3500	3500

MODELS 106-RPS-L&H / 206-RPS-L&H

Surge Anticipating Relief Valve

KEY FEATURES

- Protects against power failure surges or pressure waves caused by velocity changes
- Quick opening relief
- Easily adjustable pressure setting
- No electrical services required

PRODUCT OVERVIEW

The 106-RPS-L&H and 206-RPS-L&H anticipating surge relief valves are based on the 106-PG or 206-PG main valve.

The valve is mounted in a tee, downstream of the pump check valve(s). It is designed to anticipate surges to avoid the severe water hammer often associated with power failure surges.

The RPS-L&H pilot system is comprised of two pilots, the 81-RP and the 82-PR. Both pilots sense pressure through a connection to the header pipe. The 81-RP high pressure pilot opens the valve to relieve excess pressure. The model 82-PR low pressure pilot opens quickly on below normal pressures prior to the return of a surge wave, initiating the opening of the main valve in anticipation of the high pressure wave's arrival.



TYPICAL APPLICATION

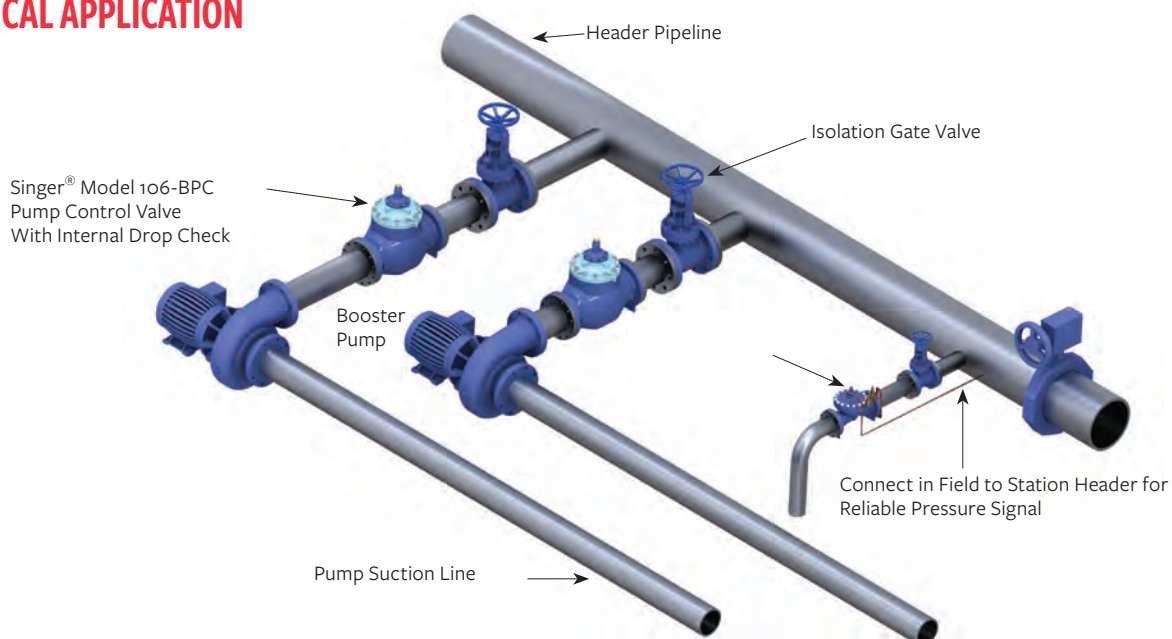

MODELS 106-RPS-L&H / 206-RPS-L&H

Surge Anticipating Relief Valve

SCHEMATIC DRAWING

NO.	PART
1	Main Valve - 106-PG or 206-PG
2	Isolation Valve (2A, 2B, 2C), Standard All Sizes
3	Strainer - 40 Mesh Screen
4	Closing Speed Control - Model 852-B
5	Test Needle Valve - Normal Position Fully Open
6	Pressure Gauge - 1/4" / 6.35 mm, NPT - by Others
7	Test Needle Valve - Normal Position Fully Closed
8	Model 82-PR - Low Surge Pilot Specify for 7 to 50 / 0.48 to 3.5 bar, 45 to 200 psi / 3.1 to 13.8 bar or 100 to 300 psi / 6.9 to 20.7 bar
9	Model 81-RP - High Surge Pressure Pilot Specify for 5 to 50 psi / 0.35 to 3.5 bar, 10 to 80 psi / 0.7 to 5.5 bar, 100 to 300 psi / 6.9 to 20.7 bar. Standard 20 to 200 psi / 1.38 to 13.8 bar
10	Pipe Plug for Gauge Connection
11	Swing Check Valve - 1/2" / 15 mm

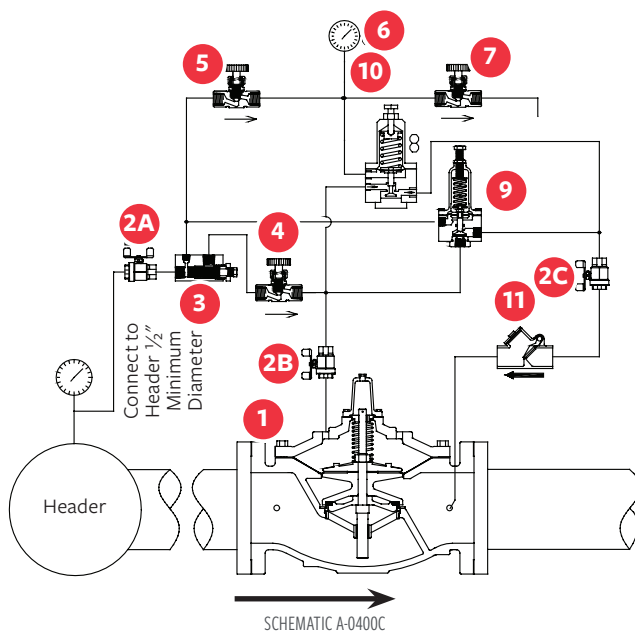

Note: Schematic shown is for 2" / 50 mm to 6" / 150 mm. For 8" / 200 mm and higher refer to Schematic A-0401C

STANDARD MATERIALS

Standard materials for pilot system components are:

- ASTM B-62 bronze or ASTM B-16 brass
- AISI 303 / 316 stainless steel trim

SELECTION SUMMARY

1. Anticipating surge relief valves should be sized from information provided by an engineer's surge analysis of the system.
2. In the absence of such information, as a general guide, a valve selected to pass 25% of the maximum normal flow when the valve is fully open, calculated with the static pressure as the pressure drop across the valve, has been successful in practice. Over sizing may cause problems. Valve may not close if oversized.
3. Ensure that the recovered header pressure (static) exceeds the low pressure relief pilot setting, otherwise the valve will not close. As a guide, a setting at 60% of static pressure has been suitable.
4. Ensure the maximum working pressure rating of the valve and flanges exceeds the maximum operating pressure.
5. Select either a standard globe style body or the optional angle style body.
6. If the RPS-L&H is sized properly, a hydraulic travel limiter is unnecessary. Should an engineer insist that the travel limiter be included, then it will be offered as an option (add HFL to model number).
7. Should only be used on static pressures greater than 100' / 30 m / 43.5 psi.

ORDERING INSTRUCTIONS

Refer to page 244 for the order form and ordering instructions.

Additionally, include the following information for this product:

1. Single chamber (106) or (206)
2. Pilot ranges
3. HFL – Hydraulic Flow Limiter available

MODELS 106-RPS-L&H / 206-RPS-L&H

Surge Anticipating Relief Valve

106-RPS-L&H

FLOW CAPACITY 45 FT/S OR 14 M/S
(SEE 106-PG IN MAIN VALVE SECTION FOR OTHER VALVE DATA)

Size (Inches)	½"	¾"	1"	1 ¼"	1 ½"	2"	2 ½"	3"	4"
Size (mm)	15 mm	19 mm	25 mm	32 mm	40 mm	50 mm	65 mm	80 mm	100 mm
Momentary (USGPM)	-	-	-	-	-	470	670	1030	1800
Momentary (L/s)	-	-	-	-	-	30	42	65	114

106-RPS-L&H

FLOW CAPACITY 45 FT/S OR 14 M/S
(SEE 106-PG IN MAIN VALVE SECTION FOR OTHER VALVE DATA)

Size (Inches)	6"	8"	10"	12"	14"	16"	20"	24"	36"
Size (mm)	150 mm	200 mm	250 mm	300 mm	350 mm	400 mm	500 mm	600 mm	900 mm
Momentary (USGPM)	4000	7000	11000	16000	19000	25000	39000	56200	124700
Momentary (L/s)	252	442	694	1009	1199	1577	2461	3546	7868

206-RPS-L&H

FLOW CAPACITY 45 FT/S OR 14 M/S
(SEE 206-PG IN MAIN VALVE SECTION FOR OTHER VALVE DATA)

Size (Inches)	3"	4"	6"	8"	10"	12"	16"	18"	20"
Size (mm)	80 mm	100 mm	150 mm	200 mm	250 mm	300 mm	400 mm	450 mm	500 mm
Momentary (USGPM)	564	1236	2160	4800	8400	13200	19200	30000	30050
Momentary (L/s)	36	78	136	303	530	833	1211	1893	1896

206-RPS-L&H

FLOW CAPACITY 45 FT/S OR 14 M/S
(SEE 106-PG IN MAIN VALVE SECTION FOR OTHER VALVE DATA)

Size (Inches)	24 x 16"	24 x 20"	28"	30"	32"	36"	40"	48"
Size (mm)	600 x 400 mm	600 x 500 mm	700 mm	750 mm	800 mm	900 mm	1000 mm	1200 mm
Momentary (USGPM)	30100	39000	67440	67490	67540	67640	124700	124700
Momentary (L/s)	1899	2461	4255	4258	4261	4268	7868	7868

MODELS 106-RPS-RR / 206-RPS-RR

Surge Anticipating on Rate of Rise of Pressure Relief Valve

KEY FEATURES

- Protects against power failure surges or pressure waves caused by velocity changes
- Unaffected by header pressure and over sizing
- Quick opening relief
- Easily adjustable pressure setting
- No electrical services required

PRODUCT OVERVIEW

The 106-RPS-RR and 206-RPS-RR surge anticipating relief on rate of rise valves are based on the 106-PG or 206-PG main valve.

The valve is installed downstream of the pump check valve(s) and has two pilots, the 81-RP and the 81-RPD. Both pilots sense pressure through a connection to the header pipe. The 81-RP high pressure pilot acts as a standard relief pilot, opening on excessive pressure. The 81-RPD differential pilot responds to the pressure differential across its diaphragm. A pressure differential is created when there is a system pressure increase. The flow into the

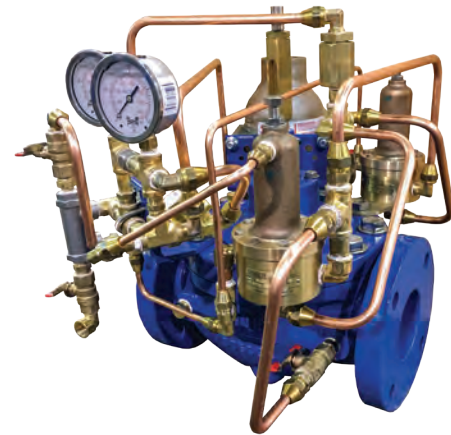

accumulator creates a pressure drop across the fixed restriction, which lowers the pressure in the connection between the fixed restriction and the pilot. The pilot senses the pressure difference between this lower pressure and the header pressure. This difference occurs at the initiation of the pressure surge, providing the time necessary for the valve to open in anticipation of the high pressure.

TYPICAL APPLICATION

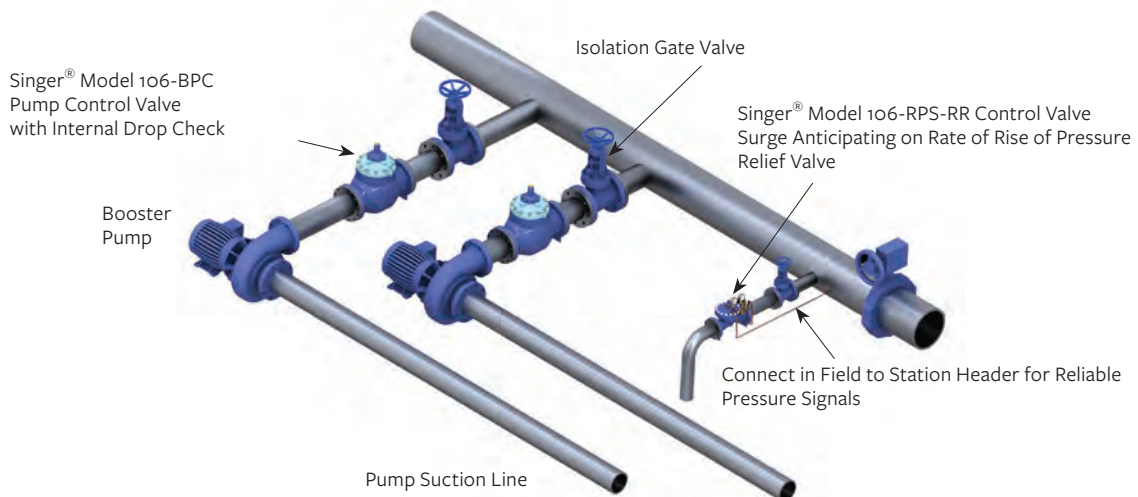

Long pipe lines and or low recovery pressure after the surge valve opens may not guarantee conventional surge valves will close. Since the RPS-RR is closing when the system pressure has stabilized, oversizing is not a problem.

MODELS 106-RPS-RR / 206-RPS-RR

Surge Anticipating on Rate of Rise Pressure Relief Valve

SCHEMATIC DRAWING

NO.	PART
1	Main Valve - 106-PG or 206-PG, Complete with X107 Position Indicator
4	Strainer Flush Valve - Normal Position Closed
5	Flow Control - J0077A
6	Connection to Header
7	Isolating Valve - Normal Position Open
8	Strainer - 40 Mesh - J0098A
9	Pressure Gauge
10	Pressure Gauge
11	Bladder Accumulator - M1408A
12	Differential Pilot - Model 81-RPD - Normally Closed
13	Relief Pilot - Model 81-RP
14	Isolating Valve (14A, 14B) - Normal Position Open
15	Fixed Restriction - $\frac{1}{16}$ " / 1.58 mm
16	Check Valve - J0040A

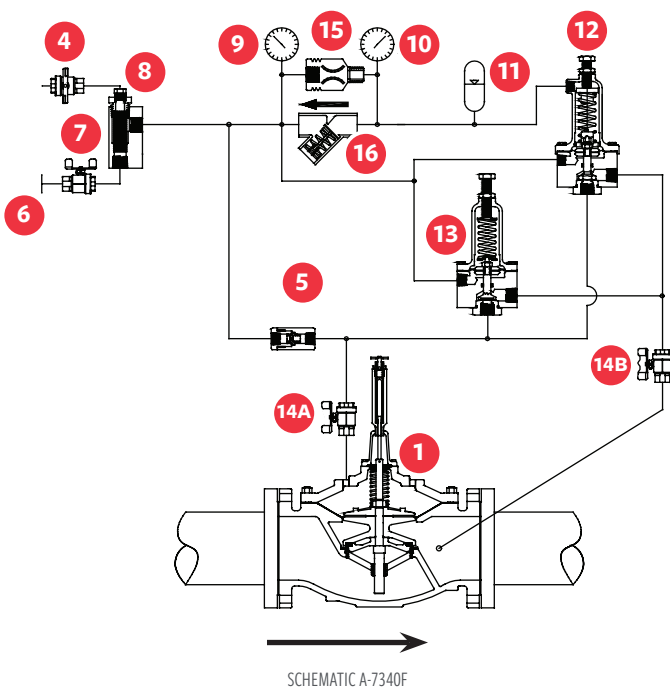

Note: Schematic shown is for 2" / 50 mm to 6" / 150 mm 106, and 3" / 80 mm to 8" / 200 mm 206. For 8" / 200 mm and higher, refer to Schematic A-7340F1

SELECTION SUMMARY

1. Anticipating surge relief valves should be sized from information provided by an engineer's surge analysis of the system.
2. In the absence of such information, as a general guide, a valve selected to pass 25% of the maximum normal flow when the valve is fully open, calculated with the static pressure as the pressure drop across the valve, has been successful in practice.
3. Ensure the maximum working pressure rating of the valve and flanges exceeds the maximum operating pressure.
4. Select either a standard globe style body or the optional angle style body.
5. Surge anticipating valves usually relieve to atmosphere which ensures high operating differential pressure and rapid response times. Momentary, "M", service range up to 45 ft/s / 14 m/s is suitable for sizing selection. Other supplementary functions are available, consult with a Singer® representative.

ORDERING INSTRUCTIONS

Refer to page 244 for the order form and ordering instructions.

Additionally, include the following information for this product:

1. Single chamber (106) or (206)
2. Pilot range

MODELS 106-RPS-RR / 206-RPS-RR

Surge Anticipating on Rate of Rise of Pressure Relief Valve

106-RPS-RR

FLOW CAPACITY 45 FT/S OR 14 M/S
(SEE 106-PG IN MAIN VALVE SECTION FOR OTHER VALVE DATA)

Size (Inches)	1/2"	3/4"	1"	1 1/4"	1 1/2"	2"	2 1/2"	3"	4"
Size (mm)	15 mm	19 mm	25 mm	32 mm	40 mm	50 mm	65 mm	80 mm	100 mm
Momentary (USGPM)	-	-	-	-	-	470	670	1030	1800
Momentary (L/s)	-	-	-	-	-	30	42	65	114

106-RPS-RR

FLOW CAPACITY 45 FT/S OR 14 M/S
(SEE 106-PG IN MAIN VALVE SECTION FOR OTHER VALVE DATA)

Size (Inches)	6"	8"	10"	12"	14"	16"	20"	24"	36"
Size (mm)	150 mm	200 mm	250 mm	300 mm	350 mm	400 mm	500 mm	600 mm	900 mm
Momentary (USGPM)	4000	7000	11000	16000	19000	25000	39000	56200	124700
Momentary (L/s)	252	442	694	1009	1199	1577	2461	3546	7868

206-RPS-RR

FLOW CAPACITY 45 FT/S OR 14 M/S
(SEE 206-PG IN MAIN VALVE SECTION FOR OTHER VALVE DATA)

Size (Inches)	3"	4"	6"	8"	10"	12"	16"	18"	20"
Size (mm)	80 mm	100 mm	150 mm	200 mm	250 mm	300 mm	400 mm	450 mm	500 mm
Momentary (USGPM)	564	1236	2160	4800	8400	13200	19200	30000	30050
Momentary (L/s)	36	78	136	303	530	833	1211	1893	1896

206-RPS-RR

FLOW CAPACITY 45 FT/S OR 14 M/S
(SEE 206-PG IN MAIN VALVE SECTION FOR OTHER VALVE DATA)

Size (Inches)	24 x 16"	24 x 20"	28"	30"	32"	36"	40"	48"
Size (mm)	600 x 400 mm	600 x 500 mm	700 mm	750 mm	800 mm	900 mm	1000 mm	1200 mm
Momentary (USGPM)	30100	39000	67440	67490	67540	67640	62000	124700
Momentary (L/s)	1899	2461	4255	4258	4261	4268	3912	7868

MODEL A106-DL

Dynamic Lifter[®] Spring Pressure Relief Valve

KEY FEATURES

- Low maintenance
- Hygienic and minimal time to flush and test operations
- Premium materials reduce maintenance, providing the lowest long-term cost of ownership

PRODUCT OVERVIEW

The A106-Dynamic Lifter (DL) sewage/dirty water pressure relief valve is a direct acting spring loaded relief valve. The valve is adjusted to open when the pressure exceeds the set-point, which is approximately 10% above the normal operating pressure. The valve closes drip-tight when pressure falls below the set-point.

The DL is connected on a tee off the main line and usually discharges relief flow back to the main sump to reduce the surge over-pressure. A speed control permits adjustment of the closing speed.

The opening force is boosted by the line pressure operating, via the separation chamber, on the piston. By applying external pressure to the test connection, the valve may be cycled open for routine maintenance.

IDEAL FOR:

- Raw water that contains organics
- Lower pressure sewage lift stations
- Booster sewage stations



TYPICAL APPLICATION

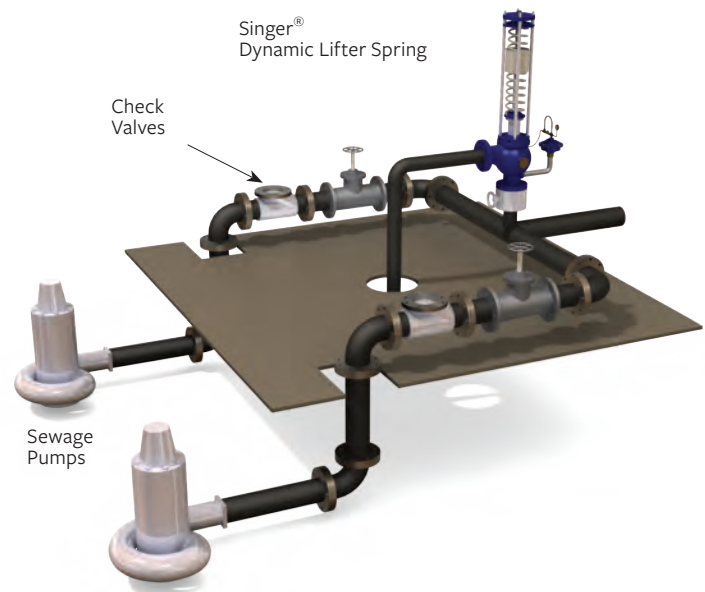

MODEL A106-DL

Dynamic Lifter® Spring Pressure Relief Valve

SCHEMATIC DRAWING

NO.	PART
1	Model A106-DL - Body
2	Diaphragm Isolator
3	Closing Speed Control
4	Isolating Valve
5	Oil Filled Isolating Valve
6	Pressure Gauge
7	Isolating Valve
8	Teflon Seated Swing Check Valve
9	Isolating valve - External Pressure for Test and Flush Cycle
10	3/8" NPT Flexible Hose
11	Isolating Valve
12	Gauge Cock

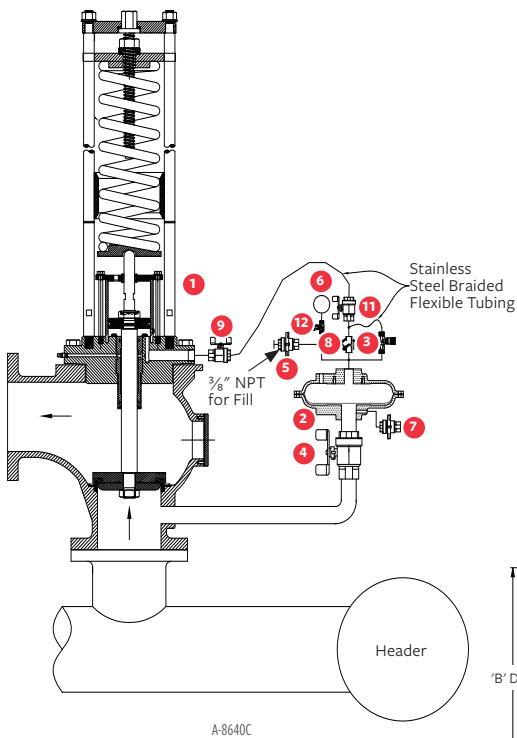

A-8640C

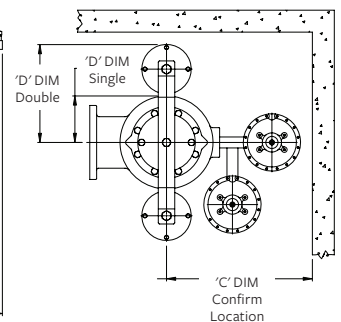
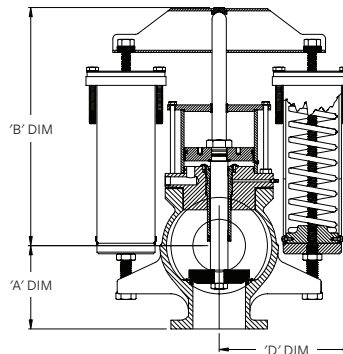
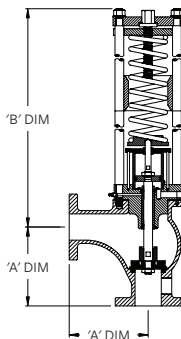

SCHEMATIC DRAWING - OPERATIONAL DETAILS

- Operating oil is separated from sewage by the chamber and diaphragm isolator (2).
- System pressure is applied to piston by mineral oil and isolator (2).
 - Piston and closing speed controls operate in clean non-contaminating environment
- System (over) pressure is applied to the opening piston throughout the full stroke.
 - Allows more relief flow as it does not lose opening force as the inner valve leaves the seat.
- By closing valve (4), external pressure may be applied through port and on to piston by the mineral oil opening of the Dynamic Lifter (1).
 - A tire pump or compressed air may be used to open the valve and check the relief setting or flush stringy material from the seat.
- Where conventional spring operated valves allow build-up of waste-water residue (dry pack) on the valve's downstream and exhaust pipe to sump, our A106-DL can easily be opened fully, through the actuator, to flush out these unwanted build-ups.
- Heat fused, heavy epoxy coating inside and out, 316 stainless steel seat and stem. The stem is also Oxy-Nitride coated to reduce mineral or debris build-up

ORDERING INSTRUCTIONS

Refer to page 244 for the order form and ordering instructions.

Additionally, include the following information for this product:

- Inlet / outlet pressure range

MODEL A106-DL

Dynamic Lifter® Spring Pressure Relief Valve

A106-DL ANSI DATA (US UNITS)

SINGLE SPRING STACK

DOUBLE SPRING STACK

Size	3"		4"		6"		8"		6"		8"	
Relief Settings (psi)												
Spring Specific Ranges	Min	Max	Min	Max	Min	Max	Min	Max	Min	Max	Min	Max
	25	70	20	65	15	30	10	15	40	90	30	50
	70	200	60	145	25	60	15	30	90	160	50	80
Other ranges available, consult with Singer Valve												
Lift / Opening	2"		2"		2 1/2"		3"		2 1/2"		3"	
Dimension A	9"		10"		11.5"		14"		11.5"		14"	
Dimension B	38.5"		39.5"		43.75"		45.75"		25.25"		26.75"	
Dimension C	30.5"		30.5"		32"		32"		32"		32"	
Dimension D	4.75"		5.75"		7.5"		10"		15.25"		18.25"	

A106-DL ANSI DATA (METRIC UNITS)

SINGLE SPRING STACK

DOUBLE SPRING STACK

Size	80 mm		100 mm		150 mm		200 mm		150 mm		200 mm	
Relief Settings (bar)												
Spring Specific Ranges	Min	Max	Min	Max	Min	Max	Min	Max	Min	Max	Min	Max
	1.72	4.83	1.38	4.48	1.03	2.07	0.69	1.03	2.76	6.21	2.07	3.45
	4.83	13.79	4.14	10.00	1.72	4.14	1.03	2.07	6.21	11.03	3.45	5.52
Other ranges available, consult with Singer Valve												
Lift / Opening	50 mm		50 mm		64 mm		76 mm		64 mm		76 mm	
Dimension A	229 mm		254 mm		292 mm		356 mm		292 mm		356 mm	
Dimension B	978 mm		1004 mm		1112 mm		1162 mm		641 mm		680 mm	
Dimension C	775 mm		775 mm		813 mm		813 mm		813 mm		813 mm	
Dimension D	121 mm		146 mm		191 mm		254 mm		387 mm		464 mm	

A106-DL ANSI DATA (US UNITS)

AIR OPERATED

Size	3"		4"		6"		8"	
Relief Settings (psi)								
Pressure Ranges	Options Available up to 200 psi, consult with Singer Valve							
Lift / Opening	2"		2"		2 1/2"		3"	
Dimension A	9"		10"		11.5"		14"	
Dimension B	22.5"		23.5"		25.5"		28.88"	
Dimension C	30.5"		30.5"		32"		32"	
Dimension D	4.75"		5.75"		7.5"		10"	

A106-DL ANSI DATA (METRIC UNITS)

AIR OPERATED

Size	80 mm		100 mm		150 mm		200 mm	
Relief Settings (bar)								
Pressure Ranges	Options Available up to 13.8 Bar, consult with Singer Valve							
Lift / Opening	50 mm		50 mm		64 mm		76 mm	
Dimension A	229 mm		254 mm		292 mm		356 mm	
Dimension B	572 mm		597 mm		648 mm		734 mm	
Dimension C	775 mm		775 mm		813m		813 mm	
Dimension D	121 mm		146 mm		191 mm		254 mm	

MODELS A106-DL-AIR / A106-DL-AIR-ET

Dynamic Lifter® Air Operated Pressure Relief Valve / Surge Anticipating Electronically Timed DL Pressure Relief Valve

KEY FEATURES

A106-DL-AIR:

- Eliminates surges and prolongs pipe life
- Adjustable closing speed
- Utilizes compress air or plant air
- Smaller profile allows installation into limited space
- Ideal for higher pressures

A106-DL-AIR-ET:

- All key features of the A106-DL-Air
- Solenoid valve anticipates surges resulting from power failures

PRODUCT OVERVIEW

The Model A106-DL-Air is a compact sewage relief valve that is suitable for high pressures up to 200 psi / 13.8 bar, responds very quickly and retains all the features and benefits of the Model A106-DL Spring-Hydraulic version. It is an attractive solution to what may be otherwise a difficult application due to higher pressures or space height limitations.

The Model A106-DL-Air-ET retains all the features and benefits of the Model A106-DL-Air with the additional feature of two 3-way solenoid valves which forces the valve open upon power failure.



TYPICAL APPLICATION

Application drawing is applicable to both A-106-DL-Air and A-106-DL-Air-ET.

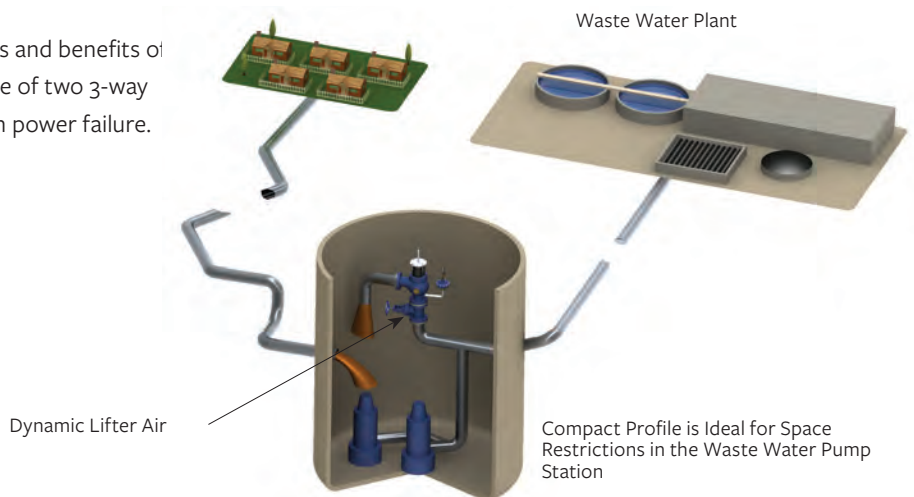

MODELS A106-DL-AIR

Dynamic Lifter® Air Operated Pressure Relief Valve

SCHEMATIC DRAWING A106-DL-AIR

NO.	PART
1	Model A106-DL-Air
2	Isolating Valve (2A, 2B)
3	Needle Valve
4	Pressure Reducing Pilot - Model 160
5	Relief Pilot - Model 81-RP
6	Pressure Gauge (6A, 6B)
7	Fixed Restriction
8	Isolating Valve
9	Diaphragm Isolator
10	Bleed Valve
11	Check Valve, J0040A
12	Bleed Valve
13	Manual Override Valve
14	Fixed Restriction
15	Air Supply
16	852B Needle Valve
17	Air Charge Valve
18	Isolating Valve
19	Isolating Valve

SCHEMATIC DRAWING A106-DL-AIR – OPERATION DETAILS

- Operates using separate compressed air supply
 - An inexpensive 120 psi / 8.3 bar air compressor may be used for 200 psi / 13.8 bar or higher relief pressures by using a large diameter closing piston.
- Using a chamber and diaphragm isolator (9), an accurate hydraulic pilot (5) opens reliably and repeatedly at its set pressure (gauge 6A)
 - Full operational (including pilot) check is quickly and cleanly performed by closing valve (8) and applying pressure at (18). For quick flush open (3).
- The check valve (11) maintains air in the operating cylinder should the air supply fail.
 - Provided the air supply is above minimum, variations in pressure do not affect the valve operation, which is controlled independently by the accurate pilot (5).
- The main valve (1) is constructed of the same premium materials as the Hydraulic Dynamic Lifter for long life and minimum maintenance.

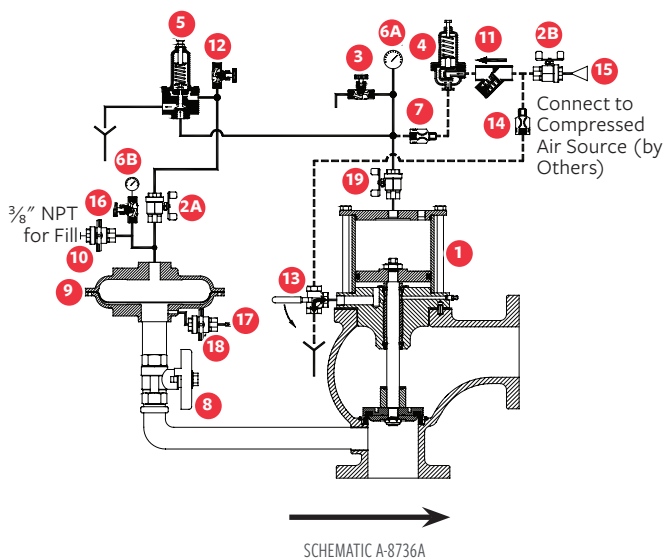

A106-DL-AIR-ET

Surge Anticipating Electronically Timed DL Pressure Relief Valve

SCHEMATIC DRAWING A106-DL-AIR

NO.	PART
1	Model A106-DL-Air
2	Isolating Valve (2A, 2B)
3	Needle Valve
4	Pressure Reducing Pilot - Model 160
5	Relief Pilot - Model 81-RP
6	Pressure Gauge (6A, 6B)
7	Fixed Restriction
8	Isolating Valve
9	Diaphragm Isolator
10	Bleed Valve
11	Check Valve, J0040A
12	Bleed Valve
13	Solenoid Valve - 3 way - NC
14	Solenoid Valve - 3 way - NO
15	Air Supply
16	852B Needle Valve
17	Air Charge Valve
18	Isolating Valve
19	Optional SAP Control Panel

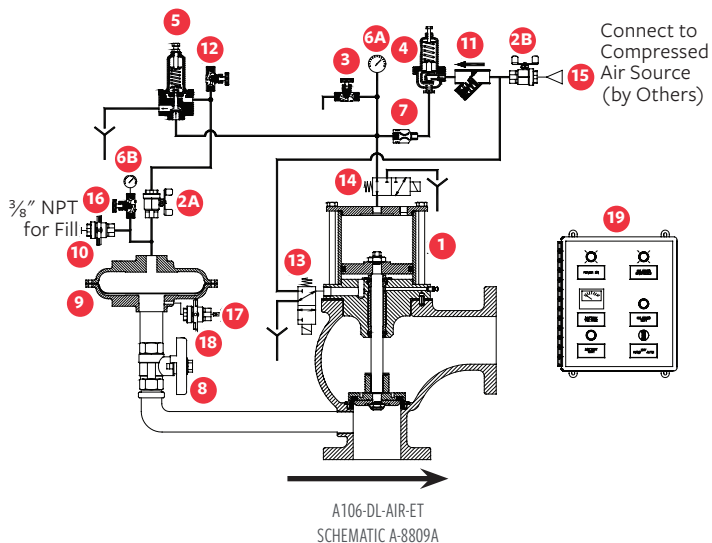

SCHEMATIC DRAWING A106-DL-AIR-ET – OPERATION DETAILS

- Operates using separate compressed air supply
 - An inexpensive 120 psi / 8.3 bar air compressor may be used for 200 psi / 13.8 bar or higher relief pressures by using a large diameter closing piston.
- Using a chamber and diaphragm isolator (9), an accurate hydraulic pilot (5) opens reliably and repeatedly at its set pressure (gauge 6A)
 - Full operational (including pilot) check is quickly and cleanly performed by closing valve (8) and applying pressure at (18). For quick flush open (3).
- The check valve (11) maintains air in the operating cylinder should the air supply fail.
 - Provided the air supply is above minimum, variations in pressure do not affect the valve operation, which is controlled independently by the accurate pilot. The main valve (1) is constructed of the same premium materials as the Hydraulic Dynamic Lifter for long life and minimum maintenance.
- Two 3-way solenoids are included to force the valve open on power failure. A backup control panel is required to time the reclosure.
- The solenoids convert the relief valve function to a surge anticipating valve if needed, particularly if there is a risk of the system going sub-atmospheric. Air pressure through solenoid holds the valve open until closed by the electrical controls

ORDERING INSTRUCTIONS

Refer to page 244 for the order form and ordering instructions.

MODELS A106-DL-AIR / A106-DL-AIR-ET

Dynamic Lifter® Air Operated Pressure Relief Valve / Surge Anticipating Electronically Timed DL Pressure Relief Valve

**A106-DL ANSI DATA
(US UNITS)**

AIR OPERATED

Size	3"	4"	6"	8"
Relief Settings (psi)				
Spring Specific Ranges	-	-	-	-
	-	-	-	-
	-	-	-	-
Pressure Ranges	Options Available up to 200 psi, consult with us			
Lift / Opening	2"	2"	2 ½"	3"
Dimension A	9"	10"	11.5"	14"
Dimension B*	22.5"	23.5"	25.5"	28.88"
Dimension C	30.5"	30.5"	32"	32"
Dimension D	4.75"	5.75"	7.5"	10"

**A106-DL ANSI DATA
(METRIC UNITS)**

AIR OPERATED

Size	80 mm	100 mm	150 mm	200 mm
Relief Settings (bar)				
Spring Specific Ranges	-	-	-	-
	-	-	-	-
	-	-	-	-
Pressure Ranges	Options Available up to 13.8 bar, consult with us			
Lift / Opening	50 mm	50 mm	64 mm	76 mm
Dimension A	229 mm	254 mm	292 mm	356 mm
Dimension B*	572 mm	597 mm	648 mm	734 mm
Dimension C	775 mm	775 mm	813 mm	813 mm
Dimension D	121 mm	146 mm	191 mm	254 mm

Pneumatic operational ranges up to 200 psi / 13.8 bar. Consult us for more information on higher pressures.

*Dimension B reflects clearance allowed for pilot system and accessories

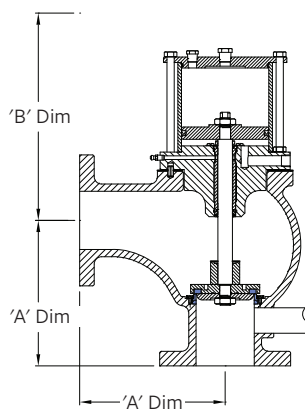

AIR OPERATED

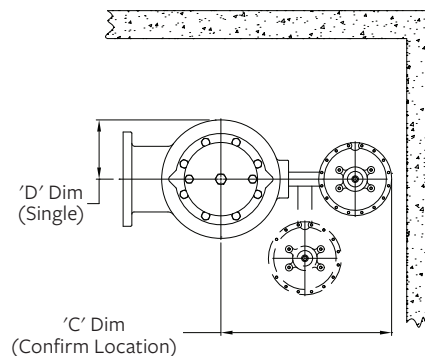

ASSEMBLY CLEARANCE

MODEL A106-DL DYNAMIC LIFTER[®] SPRING / MODEL A106-DL-ET DYNAMIC LIFTER[®] AIR

DYNAMIC LIFTER SIZING GRAPH CURVE: 3" / 80 MM - 8" / 200 MM

Conventional relief valves for sewage are typically sized "larger" than a Singer[®] Dynamic Lifter due to opening forces being lost as the inner valve leaves the seat.

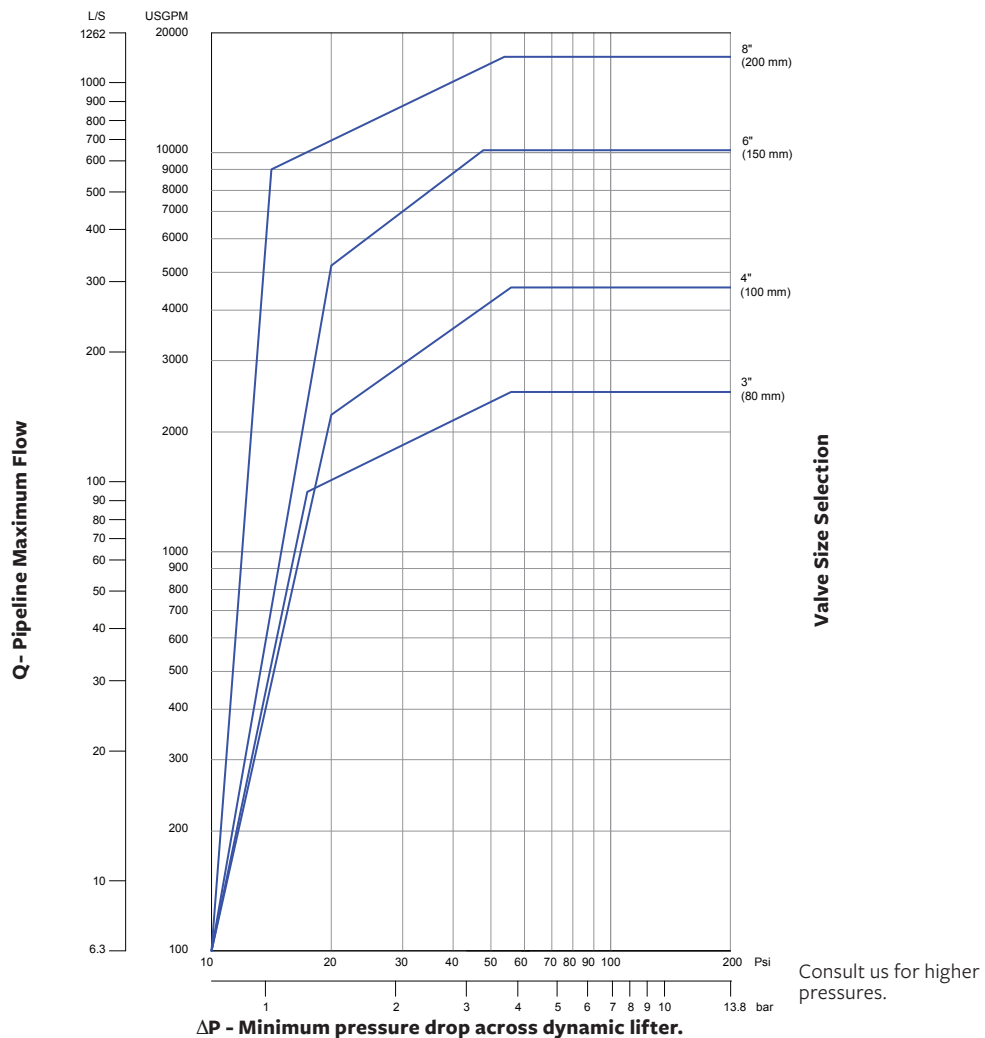

ΔP - Minimum pressure drop across dynamic lifter.

Examples of valve size selection:

- 1) Relief setting 80 psi / 5.5 bar - discharge to atmosphere: Max. flow in main pipeline 1,200 USGPM / 75.7 l/s - Find intersect of 80 psi / 5.5 bar ΔP and 1200 USGPM / 75.7 l/s flow. Select next larger size Dynamic Lifter, for example, 3" / 80 mm size.
- 2) Relief setting 55 psi / 3.8 bar - discharge 20 psi / 1.38 bar back pressure: Max. flow in main pipeline 4,000 USGPM / 252.4 l/s Find intersect of 55 psi - 20 = 35 psi / 2.4 bar ΔP and 4000 USGPM / 252.4 l/s flow. Select next larger size Dynamic Lifter, for example, 6" / 150 mm size.

Note:

- If the discharge was to atmosphere, ΔP = 55 psi / 3.8 bar and 4" / 100 mm size would be selected.
- This graph is based on current practice for standard applications. It is intended to be a guide only and no selection guarantee is implied or intended.

PUMP CONTROL VALVES

Our pump control valves substantially reduces surges that occur when a pump starts or stops. How? Because they're smart and they're smooth. They know when to open, when to close and they do it effortlessly.

MODELS 106-PG-BPC / 206-PG-BPC

Booster Pump Control Valve – Single Chamber

KEY FEATURES

- Substantially reduces pump starting and stopping surges
- Separate opening and closing speed controls
- Cost effective pump control system
- Optional internal mechanical drop check reduces power failure surge

PRODUCT OVERVIEW

The 106-PG-BPC or 206-PG-BPC booster pump control valve is installed in-line directly downstream of the pump discharge.

The valve is normally closed, and, on pump start-up, a pilot solenoid is energized to slowly open the valve, at a rate governed by the opening speed control. The pipeline flow is gradually increased.

When shut-down is required, the pilot solenoid is de-energized to close the main valve and reduce the flow. The pump is kept running while the booster pump control valve slowly closes. When the valve is almost fully closed and flow is virtually stopped, a cam triggers the limit switch to stop the pump.

With the internal drop check option, the built-in mechanical drop check closes immediately when the flow stops, regardless of the valve position. Whether due to a control malfunction, normal operation or a pump motor power failure, by closing before flow reverses, surges are minimized.

The single chamber construction facilitates supplemental modulating functions such as pressure sustaining, pressure reducing, rate of flow control. Being a single chamber design, the control forces are generated by the differential across the valve. When a modulating function is included there are more positive initial closing results.



TYPICAL APPLICATION

Singer Model 106-PG-BPC Booster Pump Control Valve Single Chamber with Internal Drop Check (optional)

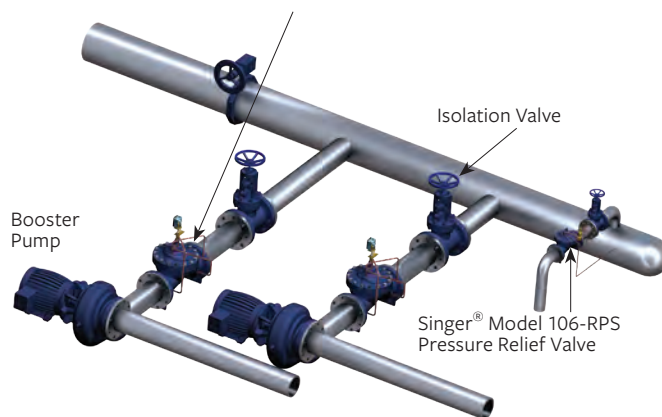

MODELS 106-PG-BPC / 206-PG-BPC

Booster Pump Control Valve – Single Chamber

SCHEMATIC DRAWING

NO.	PART
1	Main Valve - 106-PG or 206-PG
2	Isolation Valve
3	Strainer - 40 Mesh Stainless Steel Screen
4	Check Valve - Model 10
5	Micrometer Needle Valve - Closing Speed
6	Solenoid Valve - Three Way, NEMA 4
7	Micrometer Needle Valve - Opening Speed
8	Check Valve - Model 10
9	Strainer - 40 Mesh Stainless Steel Screen
10	Isolation Valve
11	Model X129 Limit Switch Assembly - NEMA 4, SPDT
12	Isolation Valve

Internal Drop Check Feature (optional, not shown)

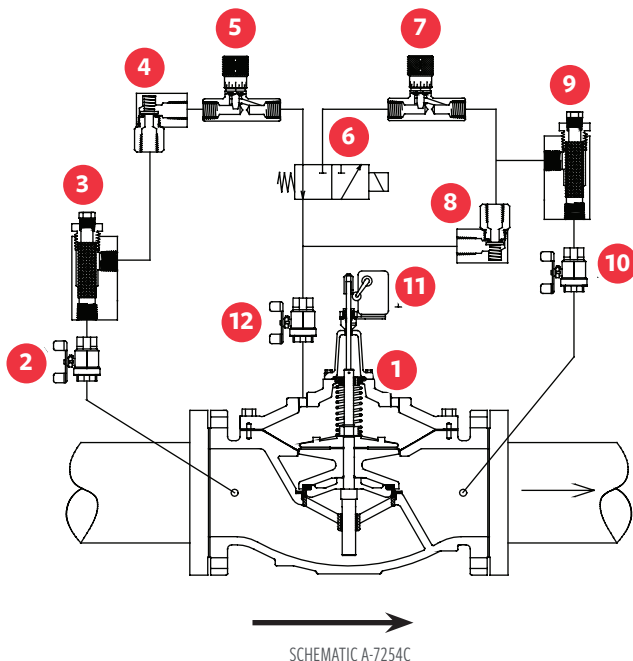

STANDARD MATERIALS

Standard materials for pilot system components are:

- ASTM B-62 bronze and ASTM B-16 brass
- AISI 303 / 316 stainless steel trim

Refer to Electronic Control section (SPC product), see page 203, and consult us for pump control panel options.

SELECTION SUMMARY

- The model PG-BPC, booster pump control valve incurs continuous head loss while the pump is operating. Refer to the 106 or 206 performance curves (see Technical & Sizing Information section, page 231). Use drooping portion of curve. Select the smallest size with a pressure drop that is acceptable.
- With no modulating pilot functions added, care should be exercised not to oversize the valve, especially if pumps are operating in parallel. With very low differential across the valve, initial closing speed will be slow. Sections 106-PG and 206-PG (Main Valve section, page 11), provide specifications and details of construction of the standard main valves while bulletin IDC - Internal Drop Check (see Main Valve Options section, page 70) provides details on the internal mechanical check option.
- Standard configuration provides for NEMA 4 watertight enclosures for the Honeywell model OP-AR, Single Pole Double Throw limit switch and the ASCO solenoid with 120 VAC / 60 Hz (or 220 VAC / 50 Hz or 240 VAC / 60 Hz) coil. For other electrical service or higher pressure ratings consult with a Singer® representative. A manual override is available upon request.

ORDERING INSTRUCTIONS

Refer to page 244 for the order form and ordering instructions.

Additionally, include the following information for this product:

1. Single chamber (106) or (206)
2. Solenoid voltage
3. Maximum inlet pressure

MODELS 106-PG-BPC / 206-PG-BPC

Booster Pump Control Valve – Single Chamber

106-PG-BPC

FLOW COEFFICIENT C_v (SEE 106-PG IN MAIN VALVE SECTION FOR OTHER VALVE DATA)

Size (Inches)	2"	2 1/2"	3"	4"
Size (mm)	50 mm	65 mm	80 mm	100 mm
C_v^1	55	80	110	200
K_v^2	48	69	95	173

206-PG-BPC

FLOW COEFFICIENT C_v (SEE 206-PG IN MAIN VALVE SECTION FOR OTHER VALVE DATA)

Size (Inches)	4"	6"	8"	10"
Size (mm)	100 mm	150 mm	200 mm	250 mm
C_v^1	150	250	505	985
K_v^2	130	216	437	852

106-PG-BPC

FLOW COEFFICIENT C_v (SEE 106-PTC IN MAIN VALVE SECTION FOR OTHER VALVE DATA)

Size (Inches)	6"	8"	10"	12"	14"	16"	20"	24"	36"
Size (mm)	150 mm	200 mm	250 mm	300 mm	350 mm	400 mm	500 mm	600 mm	900 mm
C_v^1	460	800	1300	2100	2575	3300	5100	7600	16340
K_v^2	398	692	1125	1817	2227	2855	4412	6574	14134

206-PG-BPC

FLOW COEFFICIENT C_v (SEE 206-PTC IN MAIN VALVE SECTION FOR OTHER VALVE DATA)

Size (Inches)	12"	16"	18"	20"	24 x 16"	24 x 20"	36 x 24"	40 x 36"	48 x 36"
Size (mm)	300 mm	400 mm	450 mm	500 mm	600 x 400 mm	600 x 500 mm	900 x 600 mm	1000 x 900 mm	1200 x 900 mm
C_v^1	1550	2200	3300	3400	3500	5300	7800	16340	16340
K_v^2	1341	1903	2855	2941	3028	4585	6747	14134	14134

* C_v = USGPM at 1 psi pressure drop

** K_v = m³/h at 1 bar pressure drop

$$(Q=C\sqrt{W\Delta P})$$

MODELS 106-BPC / 206-BPC

Booster Pump Control Valve – Double Chamber

KEY FEATURES

- Suitable for most pumping applications including suction lift and low differential head
- Prevents pump starting and stopping surges
- Built-in non-slam mechanical check reduces surges on loss of power
- Separate opening and closing speed controls

PRODUCT OVERVIEW

The 106-BPC and 206-BPC booster pump control valves are installed in-line, directly downstream of the pump discharge.

The pump control valve is normally closed and on pump start-up, a pilot solenoid is energized to open the valve, at a rate governed by the opening speed control. When shut-down is required the pilot solenoid on the valve is de-energized to commence closing. The pump is kept running while the valve slowly closes. When the valve is almost fully closed and flow is virtually zero, a stem mounted cam triggers the limit switch to stop the pump.

In the event of a power failure, the built-in mechanical drop check closes immediately when the flow stops, independently of the valve position. Surges are minimized by closing the valve before reverse flow occurs.



TYPICAL APPLICATION

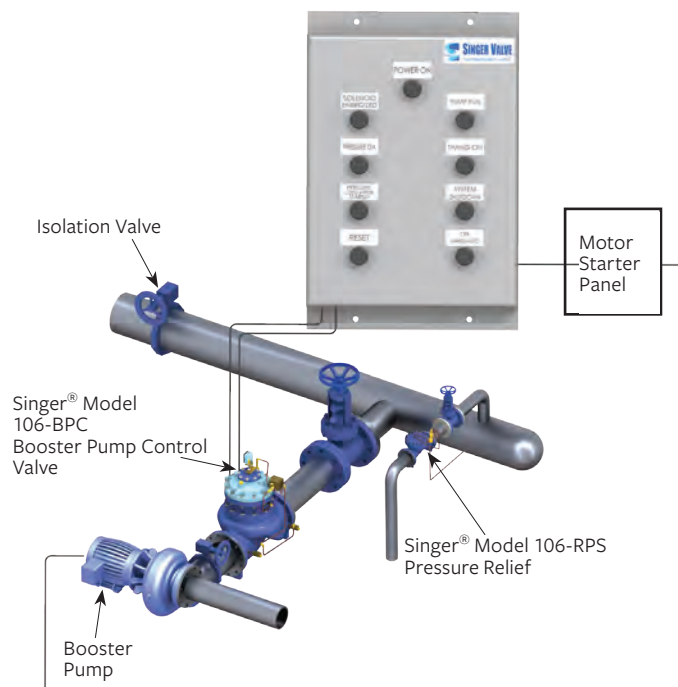

MODELS 106-BPC / 206-BPC

Booster Pump Control Valve – Double Chamber

SCHEMATIC DRAWING

NO.	PART
1	Main Valve - 106-PTC or 206-PTC
2	Strainer - (2A,2B) - 40 Mesh Stainless Steel
3	Check Valves - (3A,3B)
4	Isolation Valves - (4A,4B)
5	Micrometer Flow Control Valves - (5A Opening Speed Control, 5B Closing Speed Control)
6	Model X129 Limit Switch Assembly - NEMA 4, SPDT
7	Solenoid Valve - Four Way, NEMA 4

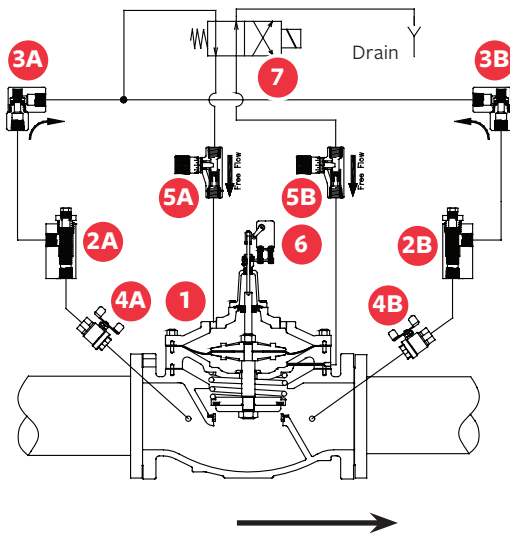

SCHEMATIC A-0426H

STANDARD MATERIALS

Standard materials for pilot system components are:

- ASTM B-62 bronze or ASTM B-16 brass
- AISI 303 / 316 stainless steel trim

Refer to Electronic Control section (SPC product), see page 203, and consult us for pump control panel options.

SELECTION SUMMARY

1. In-line pump control valves incur continuous head loss while the pump is running. Refer to the 106 or 206 performance curves (straight line) (See Technical and Sizing section, page 231). Select the smallest size meeting the capacity requirements, with a pressure drop that is acceptable.
2. Standard configuration provides for NEMA 4 watertight enclosures for the Honeywell model OP-AR, SPDT limit switch and the ASCO solenoid with 120 VAC / 60 Hz (or 220 VAC / 50 Hz or 240 VAC / 60 Hz) coil. For other electrical service or higher pressure ratings consult us. A manual override is available upon request.
3. Other functions may be combined with Booster Pump Control valves, usually in conjunction with single chamber main valves, e.g. model 106-BPC-R, pump control with pressure sustaining feature.

ORDERING INSTRUCTIONS

Refer to page 244 for the order form and ordering instructions.

Additionally, include the following information for this product:

1. Double chamber (106) or (206)
2. Solenoid voltage
3. Maximum inlet pressure

MODELS 106-BPC / 206-BPC

Booster Pump Control Valve – Double Chamber

106-BPC

FLOW COEFFICIENT C_v
(SEE 106-PTC IN MAIN VALVE SECTION FOR OTHER VALVE DATA)

Size (in)	2	2 1/2"	3"	4"	6"	8"	10"	12"	14"	16"	20"	24"
Size (mm)	50 mm	65 mm	80 mm	100 mm	150 mm	200 mm	250 mm	300 mm	350 mm	400 mm	500 mm	600 mm
C_v^1	55	80	110	200	460	800	1300	2100	2575	3300	5100	7600
K_v^2	48	69	95	173	398	692	1125	1817	2227	2855	4412	6574

206-BPC

FLOW COEFFICIENT C_v
(SEE 206-PTC IN MAIN VALVE SECTION FOR OTHER VALVE DATA)

Size (in)	3"	4"	6"	8"	10"	12"	16"	18"	20"	24 x 16"	24 x 20"	28"	30"	32"	36"
Size (mm)	80 mm	100 mm	150 mm	200 mm	250 mm	300 mm	400 mm	450 mm	500 mm	600 x 400 mm	600 x 500 mm	700 mm	750 mm	800 mm	900 mm
C_v^1	60	150	250	505	985	1550	2200	3300	3400	3500	5100	7800	7800	7900	8000
K_v^2	52	130	216	437	852	1341	1903	2855	2941	3028	4412	6747	6747	6834	6920

* C_v = USGPM at 1 psi pressure drop

** K_v = m³/h at 1 bar pressure drop

$$(Q=C\sqrt{\Delta P})$$

MODELS 106-DW / 206-DW

Deep Well Pump Control Valve – Double Chamber

KEY FEATURES

- Prevents pump starting and stopping surges
- No energy loss while pump is running
- Separate opening and closing speed controls
- Discharges initial air/water silt to waste, on well applications
- Discharges stagnant water at start-up from dormant wells

PRODUCT OVERVIEW

The 106-DW and 206-DW deep well pump control valves are installed in a tee between the pump discharge and the check valve.

The valve is normally open, and, on pump start-up, a pilot solenoid is energized to start closing the valve at a rate governed by the closing speed control.

Initially, the valve discharges air, water and sand to waste. The open valve discharges all pump flow. As the valve closes slowly, flow is transferred to the main line smoothly, increasing the pipeline flow without surges. When the valve is fully closed, all pump flow is in the pipeline, with no control valve losses.

When shut-down is required, the pilot solenoid on the valve is de-energized to commence opening. The pump is kept running while the valve slowly opens. Increasing proportion of the flow is diverted to waste with less passing through the check valve, until all flow is diverted through the nearly fully open DW valve. The pipeline check valve closes quietly without surges. When the DW valve is almost fully open, a stem mounted cam triggers the limit switch to stop the pump.



TYPICAL APPLICATION

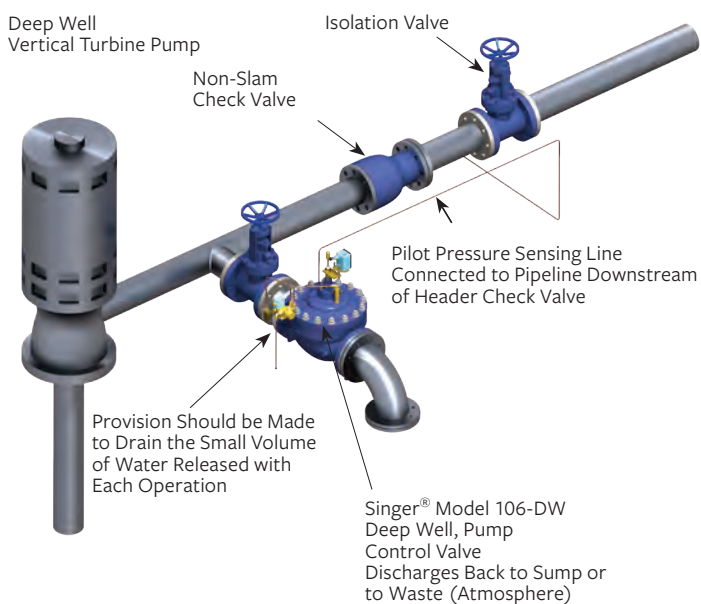

MODELS 106-DW / 206-DW

Deep Well Pump Control Valve – Double Chamber

SCHEMATIC DRAWING

NO.	PART
1	Main Valve - 106-PT or 206-PT
2	Closing Speed Control
3	Strainer - 40 Mesh Stainless Steel Screen
4	Isolation Valve
5	Connection to the Pipeline System Side of Header Check Valve - Complete in the Field
6	Exhaust to Drain - Complete in the Field
7	Solenoid Valve - Four Way, NEMA 4
8	Opening Speed Control
9	Model X129 Limit Switch Assembly - NEMA 4, SPDT

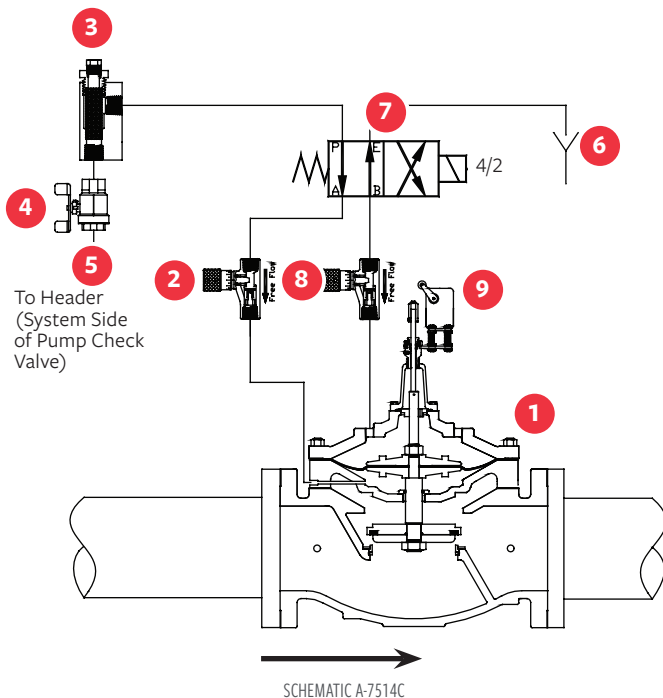

STANDARD MATERIALS

Standard materials for pilot system components are:

- ASTM B-62 bronze or ASTM B-16 brass
- AISI 303 / 316 stainless steel trim

Refer to Electronic Control section (SPC product), see page 203, and consult us for pump control panel options.

SELECTION SUMMARY

1. The Singer® model DW deep well pump control valve is sized to ensure that the pump discharge pressure is less than the system static pressure when the pump starts; that the main check valve will remain closed and no surges will be generated.
2. From the pump performance curve, determine the pump flow when the pressure at the pump discharge is 80% of the static pressure against the check valve. When the pump is discharging at full start-up flow, the combined losses of the DW control valve, the piping and the discharge losses must be less than 80% of the static pressure.
3. For pump control other than deep well applications - bypass control - the discharge from the DW control valve can be returned to the wet well, tank or even the pump suction header. Providing there is sufficient static differential pressure (e.g., 70 to 80% of the pumping differential pressure) the DW control valve should be considered preferable to a BPC, in-line booster pump control valve because of reduced sizing and operating benefits.
4. Refer to the 106 and 206 performance curves, page 231, angle or globe style (straight lines) (see Technical & Sizing Information section, page 231) and select the smallest size with the pressure drop that is acceptable. Bulletins 106-PT(C) and 206-PT(C) (see Main Valves section, page 28) provide / specifications and details of construction of the main valves. Standard configuration provides for NEMA 4 watertight enclosures for the Honeywell model OP-AR, SPDT limit switch and the ASCO solenoid with 120 VAC / 60 Hz (or 220 VAC / 50 Hz or 240 VAC / 60 Hz) coil. For other electrical service or higher pressure ratings consult with us. A manual override is available upon request. Other functions may be combined with DW valves, e.g. model 106-DW-RPS, pump control with pressure sustaining feature.

ORDERING INSTRUCTIONS

Refer to page 244 for the order form and ordering instructions.

Additionally, include the following information for this product:

1. Double chamber (106) or (206)
2. Solenoid voltage
3. Maximum inlet pressure

MODELS 106-DW / 206-DW

Deep Well Pump Control Valve – Double Chamber

106-DW

FLOW COEFFICIENT C_v (SEE 106-PT IN MAIN VALVE SECTION FOR OTHER VALVE DATA)

Size (Inches)	2"	2 1/2"	3"	4"
Size (mm)	50 mm	65 mm	80 mm	100 mm
C_v^1 - Globe	55	80	110	200
K_v^2 - Globe	48	69	95	173
C_v^1 - Angle	61	90	135	230
K_v^2 - Angle	53	78	117	199

106-DW

FLOW COEFFICIENT C_v (SEE 106-PT IN MAIN VALVE SECTION FOR OTHER VALVE DATA)

Size (Inches)	6"	8"	10"	12"	14"	16"	20"	24"
Size (mm)	150 mm	200 mm	250 mm	300 mm	350 mm	400 mm	500 mm	600 mm
C_v^1 - Globe	460	800	1300	2100	2575	3300	5100	7600
K_v^2 - Globe	398	692	1125	1817	2227	2855	4412	6574
C_v^1 - Angle	520	950	1400	2400	-	3000	-	-
K_v^2 - Angle	450	822	1211	2076	-	2595	-	-

206-DW

FLOW COEFFICIENT C_v (SEE 206-PT IN MAIN VALVE SECTION FOR OTHER VALVE DATA)

Size (Inches)	4"	6"	8"	10"
Size (mm)	100 mm	150 mm	200 mm	250 mm
C_v^1 - Globe	150	250	505	985
K_v^2 - Globe	130	216	437	852
C_v^1 - Angle	150	250	580	-
K_v^2 - Angle	130	216	502	-

206-DW

FLOW COEFFICIENT C_v (SEE 206-PT IN MAIN VALVE SECTION FOR OTHER VALVE DATA)

Size (Inches)	12"	16"	18"	20"	24 x 16"	24 x 20"	28"	30"	32"	36"
Size (mm)	300 mm	400 mm	450 mm	500 mm	600 x 400 mm	600 x 500 mm	700 mm	750 mm	800 mm	900 mm
C_v^1 - Globe	1550	2200	3300	3400	3500	5100	7800	7800	7900	8000
K_v^2 - Globe	1341	1903	2855	2941	3028	4412	6747	6747	6834	6920
C_v^1 - Angle	-	-	-	-	-	-	-	-	-	-
K_v^2 - Angle	-	-	-	-	-	-	-	-	-	-

* C_v = USGPM at 1 psi pressure drop

** K_v = m³/h at 1 bar pressure drop

$$(Q=Cv\sqrt{\Delta P})$$

MODELS 106-HC / 206-HC

Hydraulic Check Valve

KEY FEATURES

- Drip-tight seat
- Independently adjustable opening and closing speed controls

PRODUCT OVERVIEW

The 106-HC and 206-HC hydraulic check valves are based on the 106-PG or 206-PG main valve. The valve functions as a two position valve - either fully open or fully closed.

The HC allows one way flow only. Under normal forward flow, the valve opens as the higher inlet pressure lifts the inner valve assembly and the fluid in the upper chamber is discharged to the lower pressure, downstream side of the valve.

When pressure is reversed, the now higher downstream pressure is applied to the upper operating chamber as flow reversal occurs.

The diaphragm / inner valve assembly moves down and the valve closes tightly.

TYPICAL APPLICATION

Primary use as a simple, effective way to start and stop pumps without surges. No electrical supply or interconnections required. Power failure shutdown is the same as normal operation. Best used when the pump is electric motor driven and has positive suction head. A system relief valve is recommended for sizes 6" / 150 mm and larger or when velocities exceed 6 ft/s / 2 m/s.

IMPORTANT NOTE:

To provide smooth "non-slam" shutdown when the pump stops, the flow reverses for a short period. Install with forward flow over the seat. Most pumps and motors can accept reverse rotation (consult with pump manufacturer before selecting hydraulic check valves). Engine drivers will be damaged by reverse rotation - include a non-reverse clutch or similar device. No other check or foot valves should be installed to prevent reverse flow. When there is suction lift on the pump inlet, a separate form of priming is necessary. See BPC or DW valves for alternate methods of starting or stopping flows exceeding 13 f/s / 4 m/s).

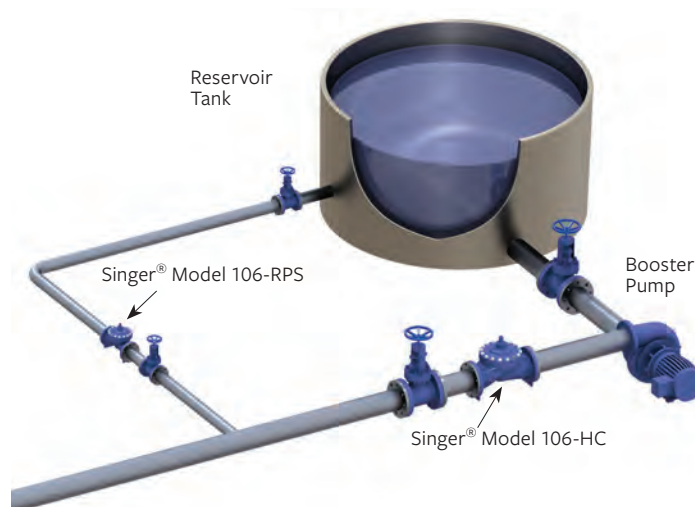

MODELS 106-HC / 206-HC

Hydraulic Check Valve

SCHEMATIC DRAWING

NO.	PART
1	Main Valve 106-PG or 206-PG - "Flow Over Seat"
2	Closing Speed Control
3	Opening Speed Control
4	Swing Check Valve - Opening
5	Swing Check Valve - Closing

The standard valve is normally installed in a horizontal pipeline with the stem oriented vertically up. Confirm other orientations before ordering.

Type Pressure Rating*

300 SCR.	200 psi / 13.8 bar
150 FLG.	200 psi / 13.8 bar
300 FLG.	300 psi / 20.7 bar

* Pressure ratings are limited by the choice of pilot components.

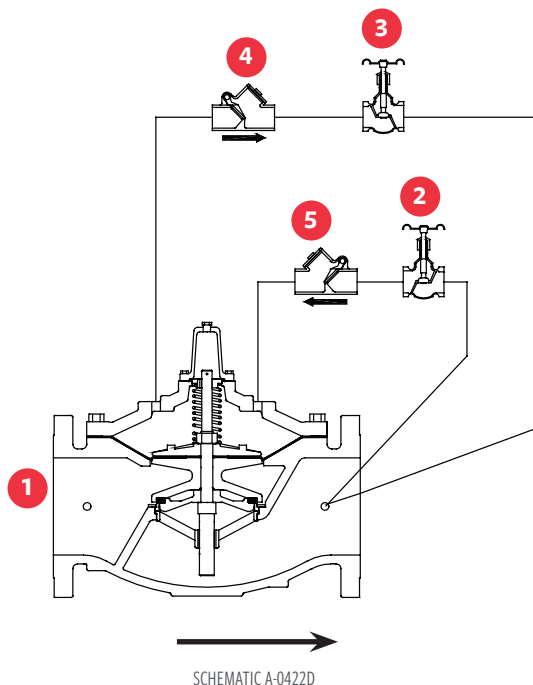

STANDARD MATERIALS

Standard materials for pilot system components are:

- ASTM B-62 bronze or ASTM B-16 brass
- AISI 303 / 316 stainless steel trim

SELECTION SUMMARY

1. Generally select size to minimize losses during normal forward flow.
2. Use the performance curves and sizing bulletin (see Technical and Sizing Information Section page 231) to check the pressure drop across the valve at normal flow rate. Use the same performance curves for flow over the seat or flow under the seat.
3. Check the maximum operating pressure. The pilot system limits the rating.
4. Standard construction provides: 200 psi / 13.8 bar
5. Rating for ANSI 150 flanged and NPT screwed ends; 300 psi / 20.7 bar rating for ANSI 300 flanged. Consult us for applications requiring higher pressure ratings.

ORDERING INSTRUCTIONS

Refer to page 244 for the order form and ordering instructions.

Additionally, include the following information for this product:

Single chamber (106) or (206)

MODELS 106-HC / 206-HC

Hydraulic Check Valve

106-HC

FLOW CAPACITY

(SEE 106-PG IN MAIN VALVE SECTION FOR OTHER VALVE DATA)

Size (Inches)	½"	¾"	1"	1 ¼"	1 ½"	2"	2 ½"	3"	4"
Size (mm)	15 mm	19 mm	25 mm	32 mm	40 mm	50 mm	65 mm	80 mm	100 mm
Max. Continuous (USGPM)	12	19	49	93	125	210	300	460	800
Max. Continuous (L/s)	0.8	1	3	6	8	13	19	29	50

106-HC

FLOW CAPACITY

(SEE 106-PG IN MAIN VALVE SECTION FOR OTHER VALVE DATA)

Size (Inches)	6"	8"	10"	12"	14"	16"	20"	24"	36"
Size (mm)	150 mm	200 mm	250 mm	300 mm	350 mm	400 mm	500 mm	600 mm	900 mm
Max. Continuous (USGPM)	1800	3100	4900	7000	8500	11000	17500	25000	55475
Max. Continuous (L/s)	114	196	309	442	536	694	1104	1577	3500

206-HC

FLOW CAPACITY

(SEE 206-PG IN MAIN VALVE SECTION FOR OTHER VALVE DATA)

Size (Inches)	3"	4"	6"	8"	10"	12"	16"	18"	20"
Size (mm)	80 mm	100 mm	150 mm	200 mm	250 mm	300 mm	400 mm	450 mm	500 mm
Max. Continuous (USGPM)	300	580	1025	2300	4100	6400	9230	16500	16500
Max. Continuous (L/s)	19	37	65	145	260	404	582	1040	1040

206-HC

FLOW CAPACITY

(SEE 206-PG IN MAIN VALVE SECTION FOR OTHER VALVE DATA)

Size (Inches)	24 x 16"	24 x 20"	28"	30"	32"	36"	40"	48"
Size (mm)	600 x 400 mm	600 x 500 mm	700 mm	750 mm	800 mm	900 mm	1000 mm	1200 mm
Max. Continuous (USGPM)	16500	21700	33600	33650	33700	33800	55475	55475
Max. Continuous (L/s)	1040	1370	2120	2123	2126	2132	3500	3500



LEVEL CONTROL VALVES

Our level control valves are the ideal solution for preventing overflow in tanks, towers and reservoirs. Repeatable, reliable operation each and every time! Our float valves directly control the maximum water level and our altitude valves control water levels from ground level. Because we hate overflow as much as you do.

MODELS 106-A-TYPE 1 / 206-A-TYPE 1

Two-Way Flow Altitude Control Valve

KEY FEATURES

- No overflows
- Superior repeatability
- Positive shut-off
- Easily serviceable at ground level

PRODUCT OVERVIEW

The 106-A-Type 1 and 206-A-Type 1 altitude control valves are based on the 106-PG or 206-PG main valve and are ideal for maintaining a preset maximum water level.

The valve functions as a two position control valve, either fully open or fully closed. The Type 1 allows normal forward flow to fill the reservoir to the maximum level and then closes drip-tight at the set-point. It opens to allow reverse flow through the valve when the supply pressure drops a fixed amount below the reservoir head. When a higher supply pressure is restored, the Type 1 valve will then allow normal forward flow to refill the tank to the maximum level.

TYPICAL APPLICATION

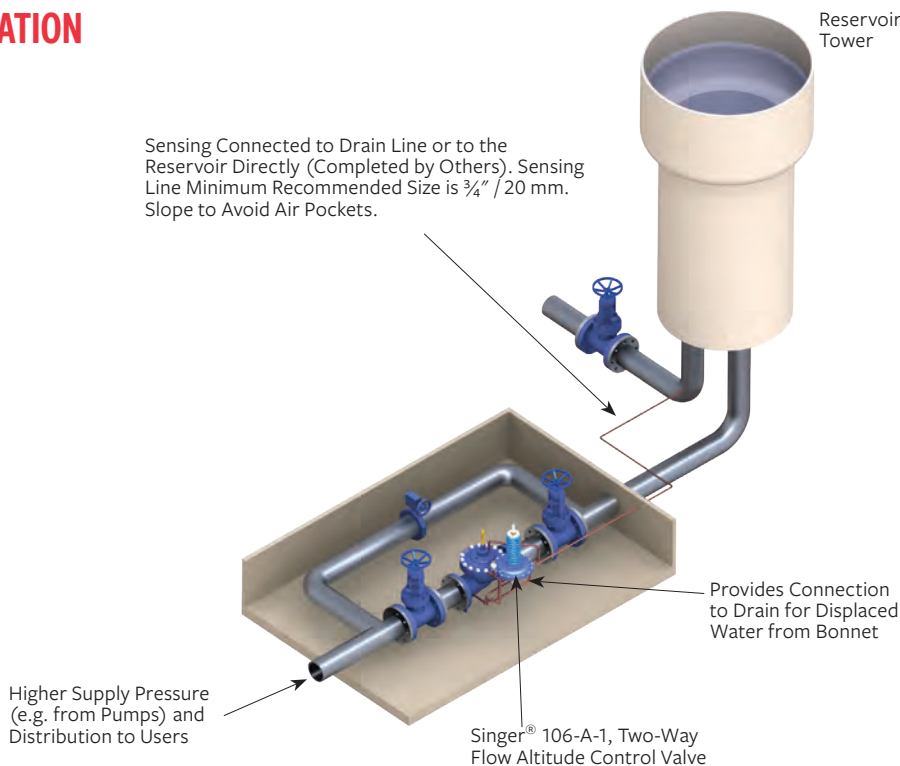

MODELS 106-A-TYPE 1 / 206-A-TYPE 1

Two-Way Flow Altitude Control Valve

SCHEMATIC DRAWING

NO.	PART
1	Main Valve - 106-PG or 206-PG - with X107 Position Indicator
2	Isolation Valve
3	Strainer - 40 Mesh Stainless Steel Screen
4	Model 10 Check Valve
5	Closing Speed Control
6	Model 12 Check Valve
7	Model 301-4 Altitude Pilot
8	Altitude Gauge
9	Fixed Restriction - $\frac{1}{8}$ " / 3.2 mm, $\frac{1}{16}$ " / 1.58 mm
10	Union
11	Isolation Valve
12	Connection to Reservoir - Complete in Field
13	Model 12 Check Valve
14	Isolation Valve

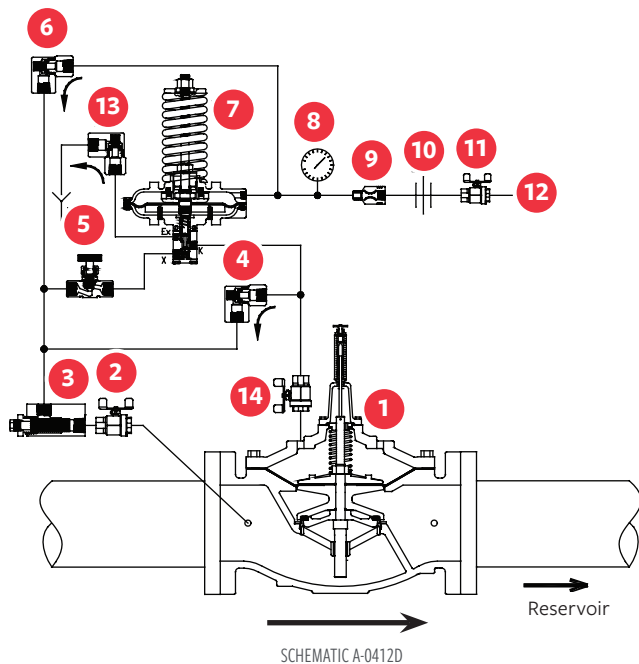

STANDARD MATERIALS

Standard materials for pilot system components are:

- Ductile Iron
- Stainless Steel
- Brass
- Copper

SELECTION SUMMARY

1. Generally select line size to minimize losses during normal forward flow.
2. Use the performance curves and sizing bulletin to determine the pressure drop across the valve.
3. Limit maximum continuous flow velocity to 20 ft/s / 6 m/s for 106 and 16 ft/s / 5 m/s for 206. Consult us if higher flows are expected.
4. The pilot system exhausts to atmosphere, ensuring the valve opens fully; requires that the displaced volume of water be taken to drain with each opening.
5. Select pilot spring range: 4' to 20' / 1 to 6 m; 10' to 60' / 3 to 18 m; 40' to 125' / 12 to 38 m; 60' to 220' / 18 to 67 m.
6. There is a non-adjustable differential required between the reservoir head and the supply pressure in order for the valve to open. It ranges from 1' / 0.3 m to 3' / 0.90 m for the pilot spring ranges listed.

ORDERING INSTRUCTIONS

Refer to page 244 for the order form and ordering instructions.

Additionally, include the following information for this product:

1. Single chamber (106) or (206)
2. Pilot range

MODELS 106-A-TYPE 1 / 206-A-TYPE 1

Two-Way Flow Altitude Control Valve

106-A-TYPE 1

FLOW COEFFICIENT C_v (SEE 106-PG IN MAIN VALVE SECTION FOR OTHER VALVE DATA)

Size (Inches)	3"	4"	6"	8"
Size (mm)	80 mm	100 mm	150 mm	200 mm
C_v^1	110	200	460	800
K_v^2	95	173	398	599

106-A-TYPE 1

FLOW COEFFICIENT C_v (SEE 106-PG IN MAIN VALVE SECTION FOR OTHER VALVE DATA)

Size (Inches)	10"	12"	14"	16"	20"	24"	36"
Size (mm)	250 mm	300 mm	350 mm	400 mm	500 mm	600 mm	900 mm
C_v^1	1300	2100	2575	3300	5100	7600	16340
K_v^2	1125	1817	2227	2855	4412	6574	14134

206-A-TYPE 1

FLOW COEFFICIENT C_v (SEE 206-PG IN MAIN VALVE SECTION FOR OTHER VALVE DATA)

Size (Inches)	3"	4"	6"	8"
Size (mm)	80 mm	100 mm	150 mm	200 mm
C_v^1	60	150	250	505
K_v^2	52	130	216	437

206-A-TYPE 1

FLOW COEFFICIENT C_v (SEE 206-PG IN MAIN VALVE SECTION FOR OTHER VALVE DATA)

Size (Inches)	10"	12"	16"	18"	20"	24 x 16"	24 x 20"	28"	30"	32"	36"	40"	48"
Size (mm)	250 mm	300 mm	400 mm	450 mm	500 mm	600 x 400 mm	600 x 500 mm	700 mm	750 mm	800 mm	900 mm	1000 mm	1200 mm
C_v^1	985	1550	2200	3300	3400	3500	5100	7800	7800	7900	8000	16340	16340
K_v^2	852	1341	1903	2855	2941	3028	4412	6747	6747	6834	6920	14134	14134

* C_v = USGPM at 1 psi pressure drop

** K_v = m³/h at 1 bar pressure drop

$$(Q = C_v \sqrt{\Delta P})$$

Note: Based on fully open valve

MODELS 106-A-TYPE 2 / 206-A-TYPE 2

One-Way Flow Altitude Control Valve

KEY FEATURES

- No overflows - high level shut-off maintained to close tolerances
- Superior repeatability
- Positive shut-off
- Easily serviceable at ground level

PRODUCT OVERVIEW

The 106-A-Type 2 and 206-A-Type 2 altitude control valves are based on the 106-PG or 206-PG main valve and are ideal for maintaining a preset maximum water level.

The valve functions as a two position control valve, either fully open or fully closed. The Type 2 valve allows normal forward flow to fill the reservoir to the maximum level and then closes drip-tight at the set-point. It opens to refill the tank once the level drops a fixed distance below the high water level.

Note: This valve does not operate as a check valve to prevent reverse flow.

TYPICAL APPLICATION

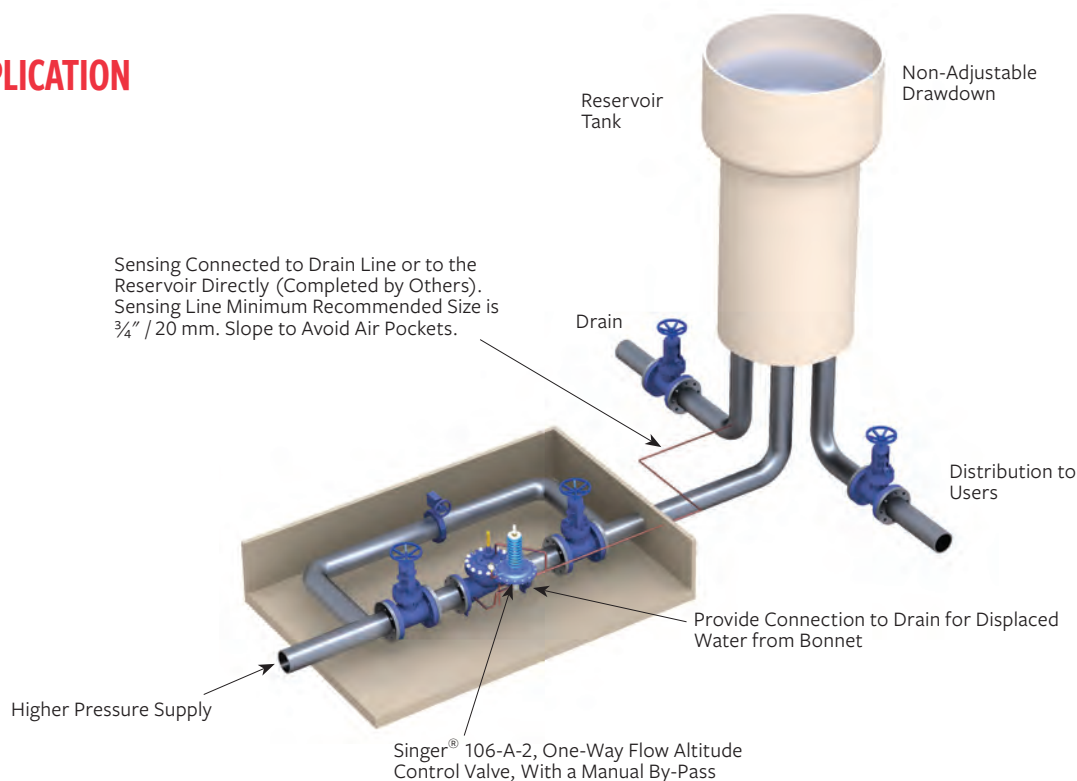
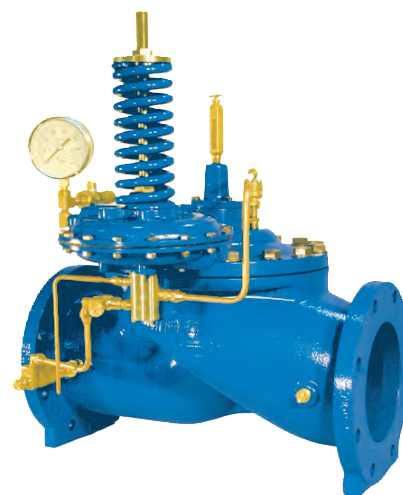

MODELS 106-A-TYPE 2 / 206-A-TYPE 2

One-Way Flow Altitude Control Valve

SCHEMATIC DRAWING

NO.	PART
1	Main Valve - 106-PG or 206-PG - with X107 Position Indicator
2	Strainer - 40 Mesh Stainless Steel Screen
3	Model 301-4 Altitude Pilot
4	Closing Speed Control
5	Altitude Gauge
6	Isolation Valve
7	Union
8	Isolation Valve
9	Sensing Connection to Reservoir (Complete in Field by Others)
10	Isolation Valve

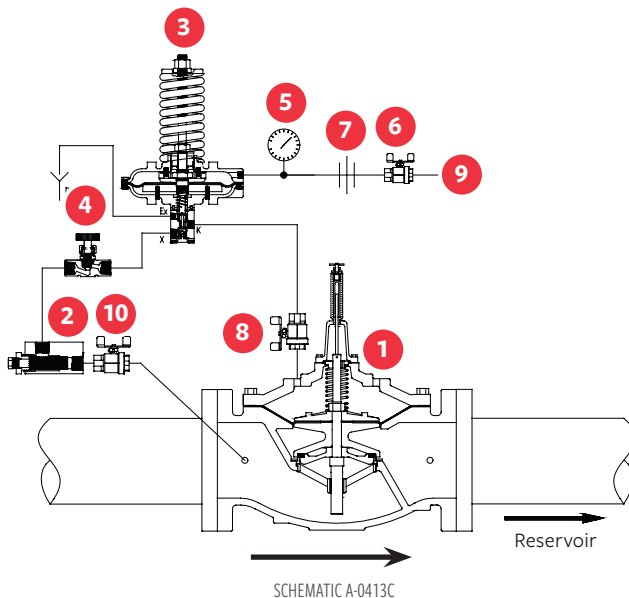

STANDARD MATERIALS

Standard materials for pilot system components are:

- Ductile Iron
- Stainless Steel
- Brass
- Copper

SELECTION SUMMARY

1. Generally select line size to minimize losses during normal forward flow.
2. Use the performance curves and sizing bulletin to determine the pressure drop across the valve.
3. Maximum continuous flow - 106 is 20 ft/s / 6 m/s, 206 is 16 ft/s / 5 m/s. Consult us if higher flows are expected.
4. The pilot system exhausts to atmosphere ensuring the valve opens fully; requires that the displaced volume of water be taken to drain with each opening.
5. Select pilot spring range. Standard (301-4) is 10' to 60' / 3 to 18 m. Specify for 301-4 ranges 4' to 20' / 1 to 6 m, 40' to 125' / 12 to 38 m, 60' to 220' / 18 to 67 m.
6. Level drop required to open: 1' to 3' / 0.3 m to 0.91 m approximate.
7. If the fill line discharges below the reservoir surface, an internal drop check or separate check valve is suggested. This prevents return flow on loss of supply pressure.

ORDERING INSTRUCTIONS

Refer to page 244 for the order form and ordering instructions.

Additionally, include the following information for this product:

1. Single chamber (106) or (206)
2. Pilot range

MODELS 106-A-TYPE 2 / 206-A-TYPE 2

One-Way Flow Altitude Control Valve

106-A-TYPE 2

FLOW COEFFICIENT C_v (SEE 106-PG IN MAIN VALVE SECTION FOR OTHER VALVE DATA)

Size (Inches)	3"	4"	6"	8"
Size (mm)	80 mm	100 mm	150 mm	200 mm
C_v^1	110	200	460	800
K_v^2	95	173	398	692

106-A-TYPE 2

FLOW COEFFICIENT C_v (SEE 106-PG IN MAIN VALVE SECTION FOR OTHER VALVE DATA)

Size (Inches)	10"	12"	14"	16"	20"	24"	36"
Size (mm)	250 mm	300 mm	350 mm	400 mm	500 mm	600 mm	900 mm
C_v^1	1300	2100	2575	3300	5100	7600	16340
K_v^2	1125	1817	2227	2855	4412	6574	14134

206-A-TYPE 2

FLOW COEFFICIENT C_v (SEE 206-PG IN MAIN VALVE SECTION FOR OTHER VALVE DATA)

Size (Inches)	3"	4"	6"	8"
Size (mm)	80 mm	100 mm	150 mm	200 mm
C_v^1	60	150	250	505
K_v^2	52	130	216	437

206-A-TYPE 2

FLOW COEFFICIENT C_v (SEE 206-PG IN MAIN VALVE SECTION FOR OTHER VALVE DATA)

Size (Inches)	10"	12"	16"	18"	20"	24 x 16"	24 x 20"	28"	30"	32"	36"	40"	48"
Size (mm)	250 mm	300 mm	400 mm	450 mm	500 mm	600 x 400 mm	600 x 500mm	700 mm	750 mm	800 mm	900 mm	1000 mm	1200 mm
C_v^1	1300	2100	2575	3300	5100	7600	16340	7800	7800	7900	8000	16340	16340
K_v^2	1125	1817	2227	2855	4412	6574	14134	6747	6747	6834	6920	14134	14134

* C_v = USGPM at 1 psi pressure drop

** K_v = m³/h at 1 bar pressure drop

$$(Q=C\sqrt{\Delta P})$$

Note: Based on fully open valve

MODELS 106-A-TYPE 3 / 206-A-TYPE 3

Two-Way Flow Altitude Control Valve with Differential Control

KEY FEATURES

- No overflows
- Superior repeatability while operating within close limits
- Positive shut-off

PRODUCT OVERVIEW

The 106-A-Type 3 and 206-A-Type 3 altitude control valves are based on the 106-PG or 206-PG main valve, and are ideal for maintaining preset maximum level.

The Type 3 allows normal forward flow to fill the reservoir to the maximum level, then closes drip-tight at the set-point. The valve opens to permit reverse flow through the valve when the supply pressure drops an adjustable amount below the reservoir head.

The Type 3 will then allow normal forward flow to refill the tank to the maximum level, when a higher supply pressure is restored.



TYPICAL APPLICATION

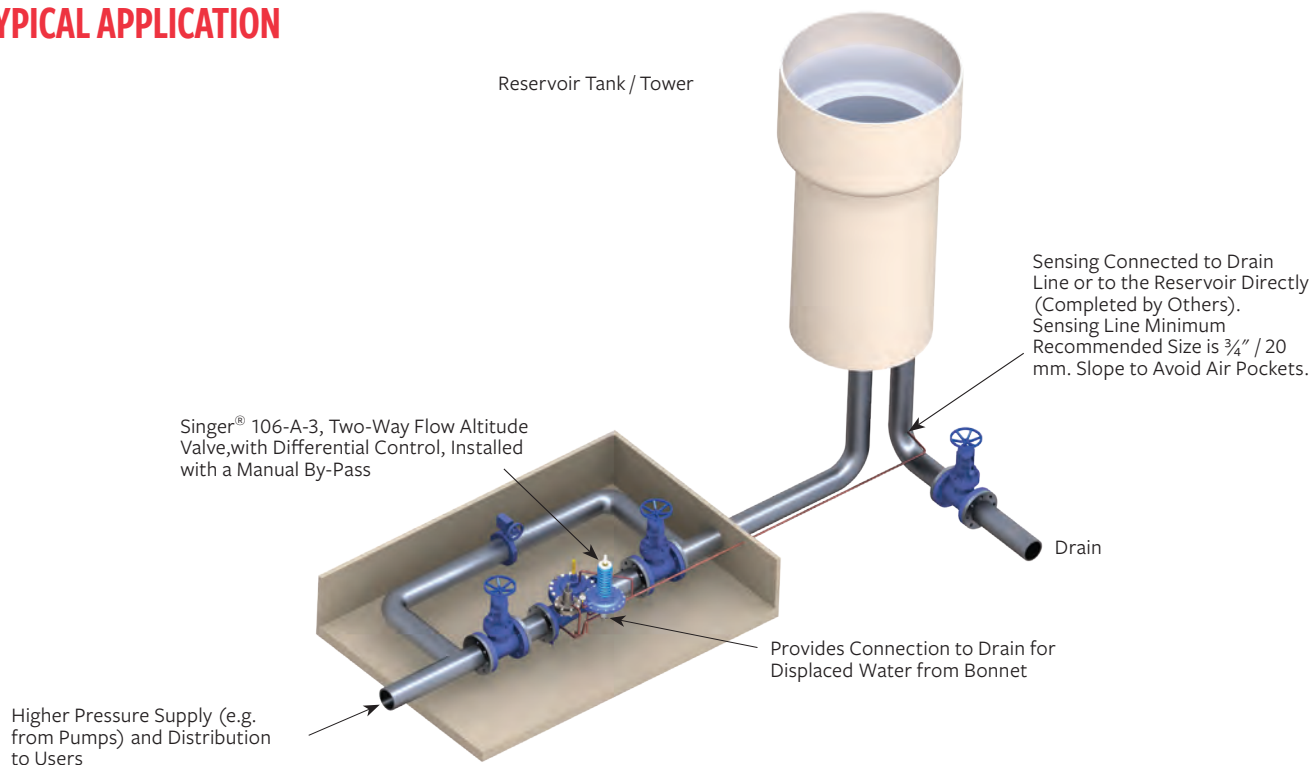

MODELS 106-A-TYPE 3 / 206-A-TYPE 3

Two-Way Flow Altitude Control Valve with Differential Control

SCHEMATIC DRAWING

NO.	PART
1	Main Valve - 106-PG or 206-PG - with X107 Position Indicator
2	Isolation Valve
3	Strainer - 40 Mesh Stainless Steel Screen
4	Model 10 Check Valve
5	Closing Speed Control
6	Model 625-RPD Differential Relief Pilot
7	Altitude Gauge
8	Isolation Valve
9	Sensing Connection to Reservoir - Complete in Field
10	Union
11	Fixed Restriction - $\frac{1}{8}$ " / 3.2 mm
12	Model 301-4 Altitude Pilot
13	Isolation Valve

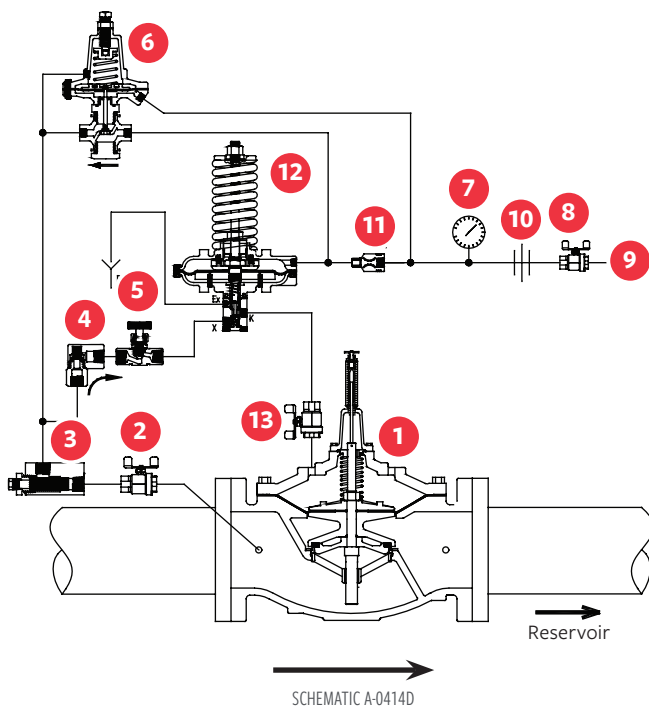

STANDARD MATERIALS

Standard materials for pilot system components are:

- Ductile Iron
- Stainless Steel

SELECTION SUMMARY

1. Generally select line size to minimize losses during normal forward flow.
2. Use the performance curves to determine the pressure drop across the valve.
3. Limit maximum continuous flow velocity to less than 20 ft/s / 6 m/s for 106 and less than 16 ft/s / 5 m/s for 206.
4. The pilot system exhausts to atmosphere ensuring the valve opens fully; requires that the displaced volume of water be taken to drain with each opening - refer to section 106-PG or 206-PG, page 12, for displaced volume
5. Select pilot spring range. Standard (301-4) is 10 to 60' / 3 to 18 m. Specify for 301-4 ranges 4' to 20' / 1 to 6 m, 40' to 125' / 12 to 38 m, 60' to 220' / 18 to 67 m.
6. Select the adjustable differential pilot spring range. Standard is 5' to 15' / 2 to 5 m. Specify for 12' to 30' / 3.7 to 9.1 m or 25' to 50' / 8 to 15 m. The total differential includes the non-adjustable differential of the altitude pilot.

ORDERING INSTRUCTIONS

Refer to page 244 for the order form and ordering instructions. Additionally, include the following information for this product:

1. Single chamber (106) or (206)
2. Pilot ranges

MODELS 106-A-TYPE 3 / 206-A-TYPE 3

Two-Way Flow Altitude Control Valve with Differential Control

106-A-TYPE 3

FLOW COEFFICIENT C_v (SEE 106-PG IN MAIN VALVE SECTION FOR OTHER VALVE DATA)

Size (Inches)	3"	4"	6"	8"
Size (mm)	80 mm	100 mm	150 mm	200 mm
C_v^1	110	200	460	800
K_v^2	95	173	398	692

106-A-TYPE 3

FLOW COEFFICIENT C_v (SEE 106-PG IN MAIN VALVE SECTION FOR OTHER VALVE DATA)

Size (Inches)	10"	12"	14"	16"	20"	24"	36"
Size (mm)	250 mm	300 mm	350 mm	400 mm	500 mm	600 mm	900 mm
C_v^1	1300	2100	2575	3300	5100	7600	16340
K_v^2	1125	1817	2227	2855	4412	6574	14134

206-A-TYPE 3

FLOW COEFFICIENT C_v (SEE 206-PG IN MAIN VALVE SECTION FOR OTHER VALVE DATA)

Size (Inches)	3"	4"	6"	8"
Size (mm)	80 mm	100 mm	150 mm	200 mm
C_v^1	60	150	250	505
K_v^2	52	130	216	437

206-A-TYPE 3

FLOW COEFFICIENT C_v (SEE 206-PG IN MAIN VALVE SECTION FOR OTHER VALVE DATA)

Size (Inches)	10"	12"	16"	18"	20"	24 x 16"	24 x 20"	28"	30"	32"	36"	40"	48"
Size (mm)	250 mm	300 mm	400 mm	450 mm	500 mm	600 x 400 mm	600 x 500 mm	700 mm	750 mm	800 mm	900 mm	1000 mm	1200 mm
C_v^1	985	1550	2200	3300	3400	3500	5100	7800	7800	7900	8000	16340	16340
K_v^2	852	1341	1903	2855	2941	3028	4412	6747	6747	6834	6920	14134	14134

* C_v = USGPM at 1 psi pressure drop

** K_v = m³/h at 1 bar pressure drop

$$(Q=C\sqrt{V\Delta P})$$

Note: Based on fully open valve

MODELS 106-A-TYPE 4 / 206-A-TYPE 4

One-Way Flow Altitude Control Valve with Differential Control

KEY FEATURES

- No overflows
- Adjustable draw-down level (differential) set-point
- Superior repeatability
- Positive shut-off
- Adjustable draw-down for improved water cycling

PRODUCT OVERVIEW

The 106-A-Type 4 and 206-A-Type 4 altitude control valves are based on the 106-PG or 206-PG main valve, and are ideal for maintaining a preset maximum water level. The valve functions as a two position control valve, either fully open or fully closed.

The Type 4 allows normal forward flow to fill the reservoir to the maximum level, then closes drip-tight at the set-point. It opens to refill the tank once the level drops an adjustable amount below the high water level.

Distribution from the reservoir is through a separate pipeline.

Note: This valve does not operate as a check valve to prevent reverse flow.

TYPICAL APPLICATION

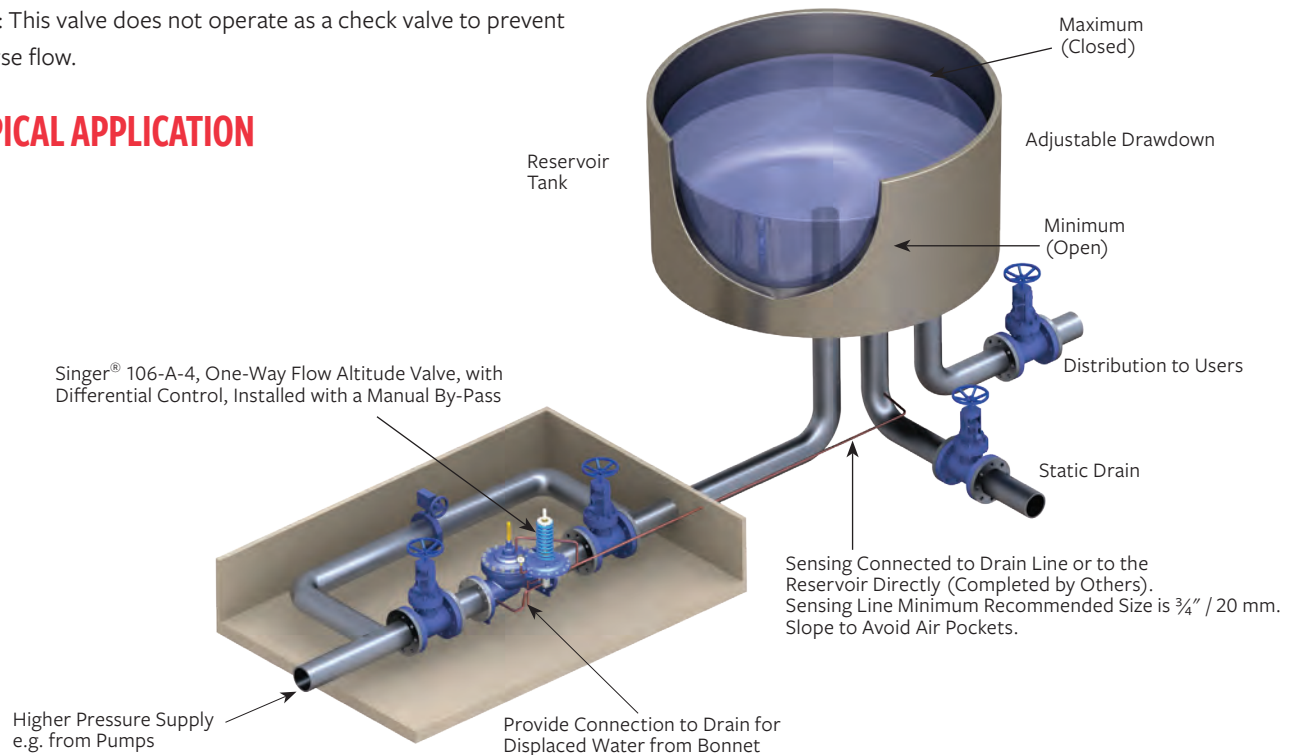

MODELS 106-A-TYPE 4 / 206-A-TYPE 4

One-Way Flow Altitude Control Valve with Differential Control

SCHEMATIC DRAWING

NO.	PART
1	Main Valve - 106-PG or 206-PG - with X107 Position Indicator
2	Isolation Valve
3	Strainer - 40 Mesh Stainless Steel Screen
4	Closing Speed Control
5	Model 301-4 Altitude Pilot
6	Model 106-RD Differential Pilot
7	Altitude Gauge - Dual Scale - Feet and Meter
8	Isolation Valve
9	Sensing Connection to Reservoir (Complete in Field by Others)
10	Model 10 Check Valve
11	Union
12	Isolation Valve

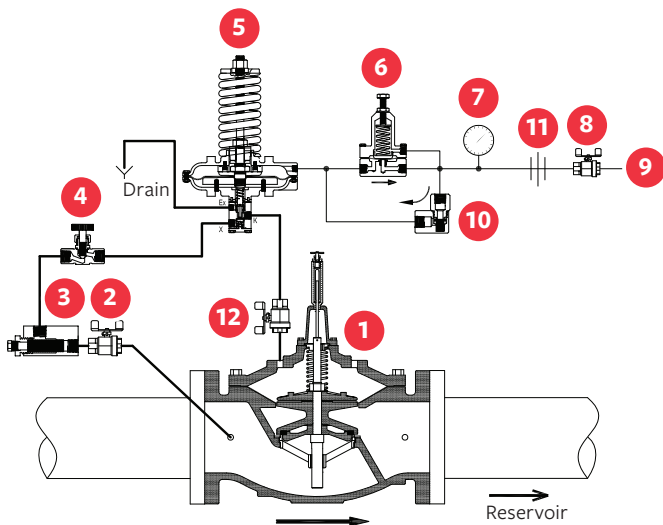

SCHEMATIC A-0415C

STANDARD MATERIALS

Standard materials for pilot system components are:

- Ductile Iron
- Stainless Steel
- Brass
- Copper

SELECTION SUMMARY

1. Generally select line size to minimize losses during normal forward flow.
2. Use the performance curves to determine the pressure drop across the valve.
3. Limit maximum continuous flow velocity to less than 20 ft/s / 6 m/s for 106 and less than 16 ft/s / 5 m/s for 206.
4. The pilot system exhausts to atmosphere ensuring the valve opens fully; requires that the displaced volume of water be taken to drain with each opening. Refer to section 106-PG or 206-PG, page 12, for the displaced volume.
5. Select pilot spring range. Standard (301-4) is 10' to 60' / 3 to 18 m. Specify for 301-4 ranges 4' to 20' / 1 to 6 m, 40' to 125' / 12 to 38 m), 60' to 220' / 18 to 67 m.
6. Select differential pilot spring range. Standard is 5' to 15' / 1.5 to 4.6 m and 10' to 50' / 3 to 15 m. Specify for 12' to 50' / 3.7 to 15 m. The total differential includes the non-adjustable differential of the altitude pilot.
7. If the fill line discharges below the reservoir surface, an internal drop check or separate check valve is suggested. This prevents return flow on loss of supply pressure.

ORDERING INSTRUCTIONS

Refer to page 244 for the order form and ordering instructions.

Additionally, include the following information for this product:

1. Single chamber (106) or (206)
2. Pilot range

MODELS 106-A-TYPE 4 / 206-A-TYPE 4

One-Way Flow Altitude Control Valve with Differential Control

106-A-TYPE 4

FLOW COEFFICIENT C_v
(SEE 106-PG IN MAIN VALVE SECTION FOR OTHER VALVE DATA)

Size (Inches)	3"	4"	6"	8"
Size (mm)	80 mm	100 mm	150 mm	200 mm
C_v^1	110	200	460	800
K_v^2	95	173	398	692

106-A-TYPE 4

FLOW COEFFICIENT C_v
(SEE 106-PG IN MAIN VALVE SECTION FOR OTHER VALVE DATA)

Size (Inches)	10"	12"	14"	16"	20"	24"	36"
Size (mm)	250 mm	300 mm	350 mm	400 mm	500 mm	600 mm	900 mm
C_v^1	1300	2100	2575	3300	5100	7600	16340
K_v^2	1125	1817	2227	2855	4412	6574	14134

206-A-TYPE 4

FLOW COEFFICIENT C_v
(SEE 206-PG IN MAIN VALVE SECTION FOR OTHER VALVE DATA)

Size (Inches)	3"	4"	6"	8"
Size (mm)	80 mm	100 mm	150 mm	200 mm
C_v^1	60	150	250	505
K_v^2	52	130	216	437

206-A-TYPE 4

FLOW COEFFICIENT C_v
(SEE 206-PG IN MAIN VALVE SECTION FOR OTHER VALVE DATA)

Size (Inches)	10"	12"	16"	18"	20"	24 x 16"	24 x 20"	28"	30"	32"	36"	40"	48"
Size (mm)	250 mm	300 mm	400 mm	450 mm	500 mm	600 x 400 mm	600 x 500 mm	700 mm	750 mm	800 mm	900 mm	1000 mm	1200 mm
C_v^1	985	1550	2200	3300	3400	3500	5100	7800	7800	7900	8000	16340	16340
K_v^2	852	1341	1903	2855	2941	3028	4412	6747	6747	6834	6920	14134	14134

* C_v = USGPM at 1 psi pressure drop

** K_v = m³/h at 1 bar pressure drop

$$(Q=C_v\sqrt{\Delta P})$$

Note: Based on fully open valve

MODELS 106-F-TYPE 4 / 206-F-TYPE 4

Modulating Float Valve

KEY FEATURES

- Maintains relatively constant level
- Automatic compensation for level draw-down
- Standard integral damping reduces hunting
- Drip-tight at high level shut-off
- Low supply pressure options

PRODUCT OVERVIEW

The Singer® model 106-F-Type 4 and 206-F-Type 4 modulating float valves are based on the 106-PG or 206-PG main valve. They are ideal for balancing the inflow and outflow demand into the reservoir and maintaining level at the designated maximum.

The valve closes drip-tight at the maximum level and modulates to maintain the tank level. The float pilot is remotely installed at the high level in the reservoir tank. Pilot connections to the main valve are connected in the field. As the reservoir level drops the main valve is opened proportionally to increase the filling rate. Movement of the main stem alters the size of the closing restriction, interrupting the tendency of the valve to hunt.



TYPICAL APPLICATION

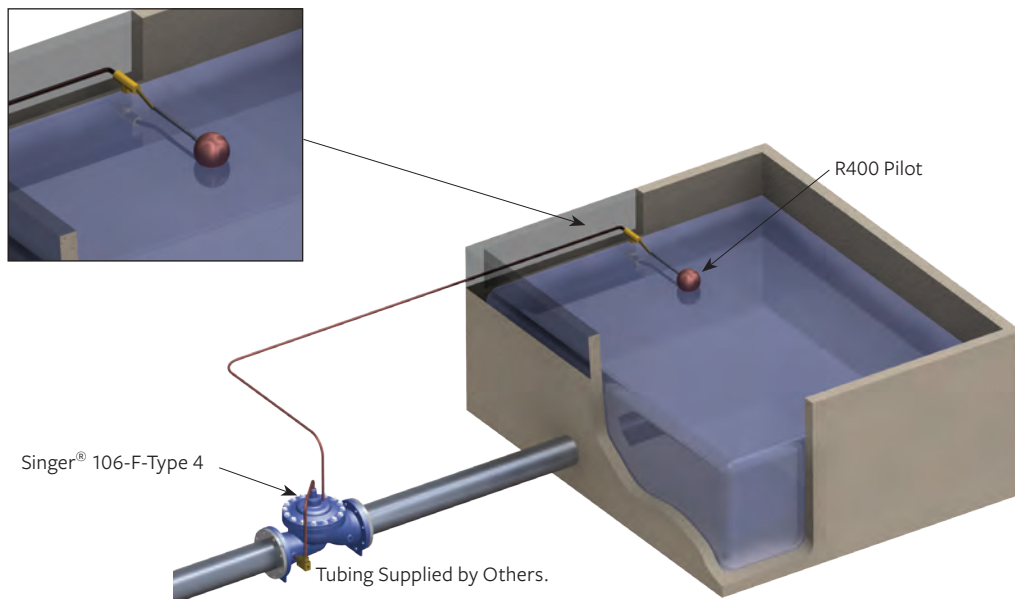

MODELS 106-F-TYPE 4 / 206-F-TYPE 4

Modulating Float Valve

SCHEMATIC DRAWING

NO.	PART
1	Main Valve - 106-PG or 206-PG, Internal Needle Stem Valve (INSV) Built Into Stem
2	Isolation Valve
3	Strainer - 40 Mesh Stainless Steel Screen
4	Isolation Valve
5	R400 Float Pilot Comes with Plastic Float

Note: Schematic shown for 2.5" / 65 mm and larger. For 2" / 50 mm and smaller, refer to Schematic A-0399C.

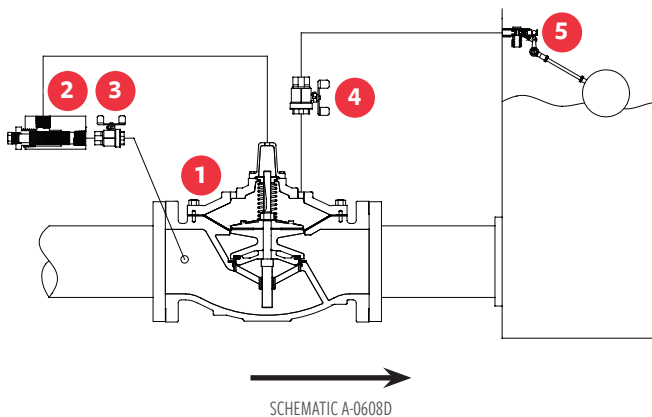

STANDARD MATERIALS

Standard materials for pilot system components are:

- Stainless Steel
- Plastic float
- Brass, Copper, Iron

Note: The stilling well and the connections between the main valve and the R-400 pilot are provided by others.

SELECTION SUMMARY

1. Generally select line size to minimize losses during normal forward flow.
2. Use the performance curves and sizing bulletin to check the pressure drop across the valve at normal flow rate.
3. Check the maximum operating pressure against the maximum working pressure rating of the flanges.
4. If the outlet pressure is less than 35% of the inlet pressure, check for cavitation.
5. If the inlet pressure is less than 10 psi / 0.7 bar higher than the maximum reservoir head, consult with us.
6. Assisted opening may be required for full flow.
 - For non-modulating (on-off) service, refer to model 106-F-Type 5 / 206-F-Type 5 float valve
 - For high tower reservoir, refer to models 106-A-Type 1 / 206-A-Type 1, or 2, or 3, or 4 Altitude Control valves.

ORDERING INSTRUCTIONS

Refer to page 244 for the order form and ordering instructions. Additionally, include the following information for this product: Single chamber (106) or (206)

MODELS 106-F-TYPE 4 / 206-F-TYPE 4

Modulating Float Valve

106-F-TYPE 4

FLOW CAPACITY (SEE 106-PG IN MAIN VALVE SECTION FOR OTHER VALVE DATA)

Size (Inches)	½"	¾"	1"	1 ¼"	1 ½"	2"	2 ½"	3"	4"
Size (mm)	15 mm	19 mm	25 mm	32 mm	40 mm	50 mm	65 mm	80 mm	100 mm
Maximum Continuous (USGPM)	12	19	49	93	125	210	300	460	800
Maximum Continuous (L/s)	0.8	1	3	6	8	13	19	29	50
Pressure Drop (PSI)	20	20	20	15	15	20	15	16	15
Pressure Drop (Bar)	1.4	1.4	1.4	1.0	1.0	1.4	1	1.1	1.0

106-F-TYPE 4

FLOW CAPACITY (SEE 106-PG IN MAIN VALVE SECTION FOR OTHER VALVE DATA)

Size (Inches)	6"	8"	10"	12"	14"	16"	20"	24"	36"
Size (mm)	150 mm	200 mm	250 mm	300 mm	350 mm	400 mm	500 mm	600 mm	900 mm
Maximum Continuous (USGPM)	1800	3100	4900	7000	8500	11000	17500	25000	55475
Maximum Continuous (L/s)	114	196	309	442	536	694	1104	1577	3500
Pressure Drop (PSI)	15	15	15	16	11	17	8.6	9.6	8.6
Pressure Drop (Bar)	1.0	1.0	1.0	1.1	0.8	1.2	0.6	0.7	0.6

206-F-TYPE 4

FLOW CAPACITY (SEE 206-PG IN MAIN VALVE SECTION FOR OTHER VALVE DATA)

Size (Inches)	3"	4"	6"	8"	10"	12"	16"	18"	20"
Size (mm)	80 mm	100 mm	150 mm	200 mm	250 mm	300 mm	400 mm	450 mm	500 mm
Maximum Continuous (USGPM)	300	580	1025	2300	4100	6400	9230	16500	16500
Maximum Continuous (L/s)	19	37	65	145	260	404	582	1040	1040
Pressure Drop (PSI)	19	15	17	21	17	17	18	23	22
Pressure Drop (Bar)	1.3	1.0	1.2	1.4	1.2	1.2	1.2	1.6	1.5

206-F-TYPE 4

FLOW CAPACITY (SEE 206-PG IN MAIN VALVE SECTION FOR OTHER VALVE DATA)

Size (Inches)	24 x 16"	24 x 20"	28"	30"	32"	36"	40"	48"
Size (mm)	600 x 400 mm	600 x 500 mm	700 mm	750 mm	800 mm	900 mm	1000 mm	1200 mm
Maximum Continuous (USGPM)	16500	21700	33600	33650	33700	33800	55470	55475
Maximum Continuous (L/s)	1040	1370	2120	2123	2126	2132	3500	3500
Pressure Drop (PSI)	21	21	17	17	17	17	17	17
Pressure Drop (Bar)	1.4	1.4	1.2	1.2	1.2	1.2	1.2	1.2

MODELS 106-F-TYPE 5 / 206-F-TYPE 5

Non-Modulating Float Valve

KEY FEATURES

- No overflow, drip-tight close
- Adjustable draw down
- Easily adjustable level settings
- Low supply pressure options

PRODUCT OVERVIEW

The 106-F-Type 5 and 206-F-Type 5 non-modulating float valves are based on the 106-PG or 206-PG main valve. It is ideal for allowing normal forward flow to fill water reservoirs to a desired high level and where the pilot and valve of the reservoirs are easily accessible.

The valve functions as a two position valve, either open or closed. The valve remains closed when the reservoir level drops, until the float reaches the pre-determined adjustable minimum reservoir level. The F-Type 5 valve then opens to refill the reservoir and closes tightly when high water level is achieved.



TYPICAL APPLICATION

Non-modulating float valves are typically used in buildings with reservoir tanks or installations where the valve and pilot are readily accessible.

The on / off service ensures that the reservoir contents are cycled. It will also prevent over cycling of the supply pumps as the minimum quantity per cycle is adjustable.

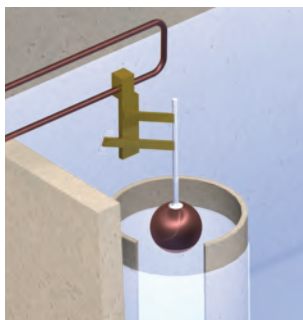

Singer® Model 106-F-Type 5 Non-Modulating Float Valve

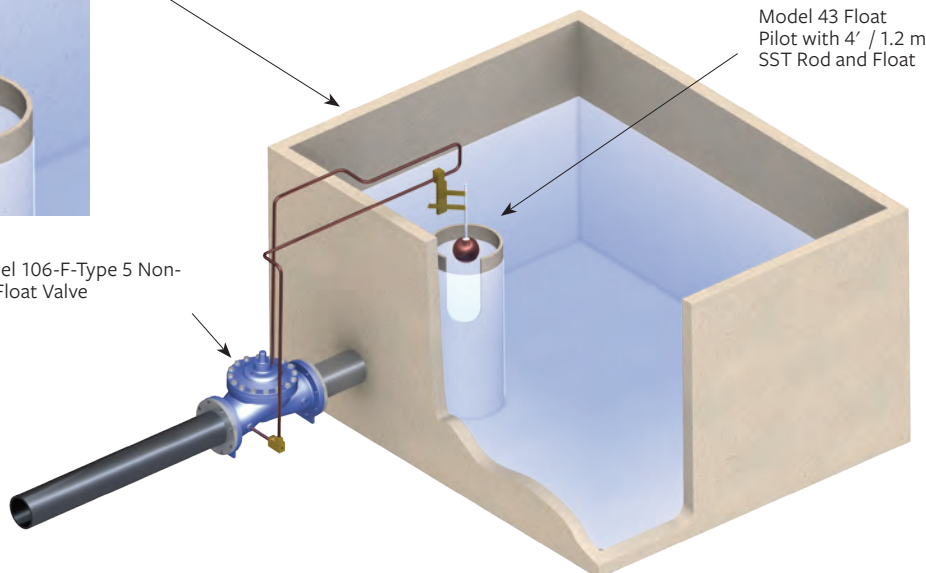

Model 43 Float Pilot with 4' / 1.2 m SST Rod and Float

MODELS 106-F-TYPE 5 / 206-F-TYPE 5

Non-Modulating Float Valve

SCHEMATIC DRAWING

NO.	PART
1	Main Valve - 106-PG or 206-PG
2	Isolation Valve
3	Strainer - 40 Mesh Stainless Steel Screen
4	Opening / Closing Speed Control
5	Model 43 Float Pilot c/w SST Float, 4' / 1.2 m SST Rod

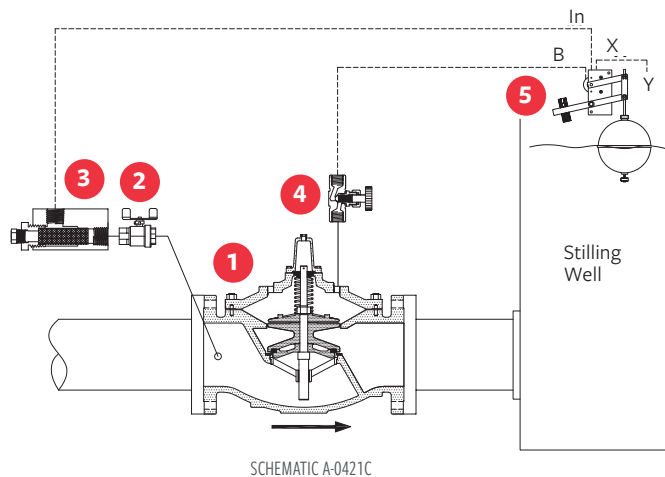

STANDARD MATERIALS

Standard materials for pilot system components are:

- ASTM B-62 bronze or ASTM B-16 brass
- Copper float

Note: The stilling well and the connections between main valve and pilot completed by others.

SELECTION SUMMARY

1. Generally select line size to minimize losses during normal forward flow - see chart of maximum continuous flow below.
2. Use the performance curves and sizing bulletin to determine the pressure drop across the valve at normal flow rate.
3. Check the maximum operating pressure against the maximum working pressure rating of the flanges.
4. For pressures greater than 250 psi / 17.2 bar, consult factory.
5. If the outlet pressure is less than 35% of the inlet pressure, check for cavitation.
6. If the inlet pressure is less than 10 psi / 0.70 bar higher than the reservoir head, consult with. Assisted opening may be required for full flow.
 - To maintain a relatively steady tank level, refer to model 106-F-Type 4 / 206-F-Type 4: Modulating Float Valve, see page 166.
 - For SCADA or electronic level control, refer to model 106-2SC-PCO / 206-2SC-PCO Dual Solenoid Control Valve

ORDERING INSTRUCTIONS

Refer to page 244 for the order form and ordering instructions.

Additionally, include the following information for this product:

1. Single chamber (106) or (206)
2. Level range

MODELS 106-F-TYPE 5 / 206-F-TYPE 5

Non-Modulating Float Valve

106-F-TYPE 5

FLOW CAPACITY (SEE 106-PG IN MAIN VALVE SECTION FOR OTHER VALVE DATA)

Size (Inches)	½"	¾"	1"	1 ¼"	1 ½"	2"	2 ½"	3"	4"
Size (mm)	15 mm	19 mm	25 mm	32 mm	40 mm	50 mm	65 mm	80 mm	100 mm
Maximum Continuous (USGPM)	12	19	49	93	125	210	300	460	800
Maximum Continuous (L/s)	0.8	1	3	6	8	13	19	29	50
Pressure Drop (PSI)	20	20	20	15	15	20	15	16	15
Pressure Drop (Bar)	1.4	1.4	1.4	1.0	1.0	1.4	1	1.1	1.0

106-F-TYPE 5

FLOW CAPACITY (SEE 106-PG IN MAIN VALVE SECTION FOR OTHER VALVE DATA)

Size (Inches)	6"	8"	10"	12"	14"	16"	20"	24"	36"
Size (mm)	150 mm	200 mm	250 mm	300 mm	350 mm	400 mm	500 mm	600 mm	900 mm
Maximum Continuous (USGPM)	1800	3100	4900	7000	8500	11000	17500	25000	55475
Maximum Continuous (L/s)	114	196	309	442	536	694	1104	1577	3500
Pressure Drop (PSI)	15	15	15	16	11	17	8.6	9.6	8.6
Pressure Drop (Bar)	1.0	1.0	1.0	1.1	0.8	1.2	0.6	0.7	0.6

206-F-TYPE 5

FLOW CAPACITY (SEE 206-PG IN MAIN VALVE SECTION FOR OTHER VALVE DATA)

Size (Inches)	3"	4"	6"	8"	10"	12"	16"	18"	20"
Size (mm)	80 mm	100 mm	150 mm	200 mm	250 mm	300 mm	400 mm	450 mm	500 mm
Maximum Continuous (USGPM)	300	580	1025	2300	4100	6400	9230	16500	16500
Maximum Continuous (L/s)	19	37	65	145	260	404	582	1040	1040
Pressure Drop (PSI)	19	15	17	21	17	17	18	23	22
Pressure Drop (Bar)	1.3	1.0	1.2	1.4	1.2	1.2	1.2	1.6	1.5

206-F-TYPE 5

FLOW CAPACITY (SEE 206-PG IN MAIN VALVE SECTION FOR OTHER VALVE DATA)

Size (Inches)	24 x 16"	24 x 20"	28"	30"	32"	36"	40"	48"
Size (mm)	600 x 400 mm	600 x 500 mm	700 mm	750 mm	800 mm	900 mm	1000 mm	1200 mm
Maximum Continuous (USGPM)	16500	21700	33600	33650	33700	33800	55470	55475
Maximum Continuous (L/s)	1040	1370	2120	2123	2126	2132	3500	3500
Pressure Drop (PSI)	21	21	17	17	17	17	17	17
Pressure Drop (Bar)	1.4	1.4	1.2	1.2	1.2	1.2	1.2	1.2

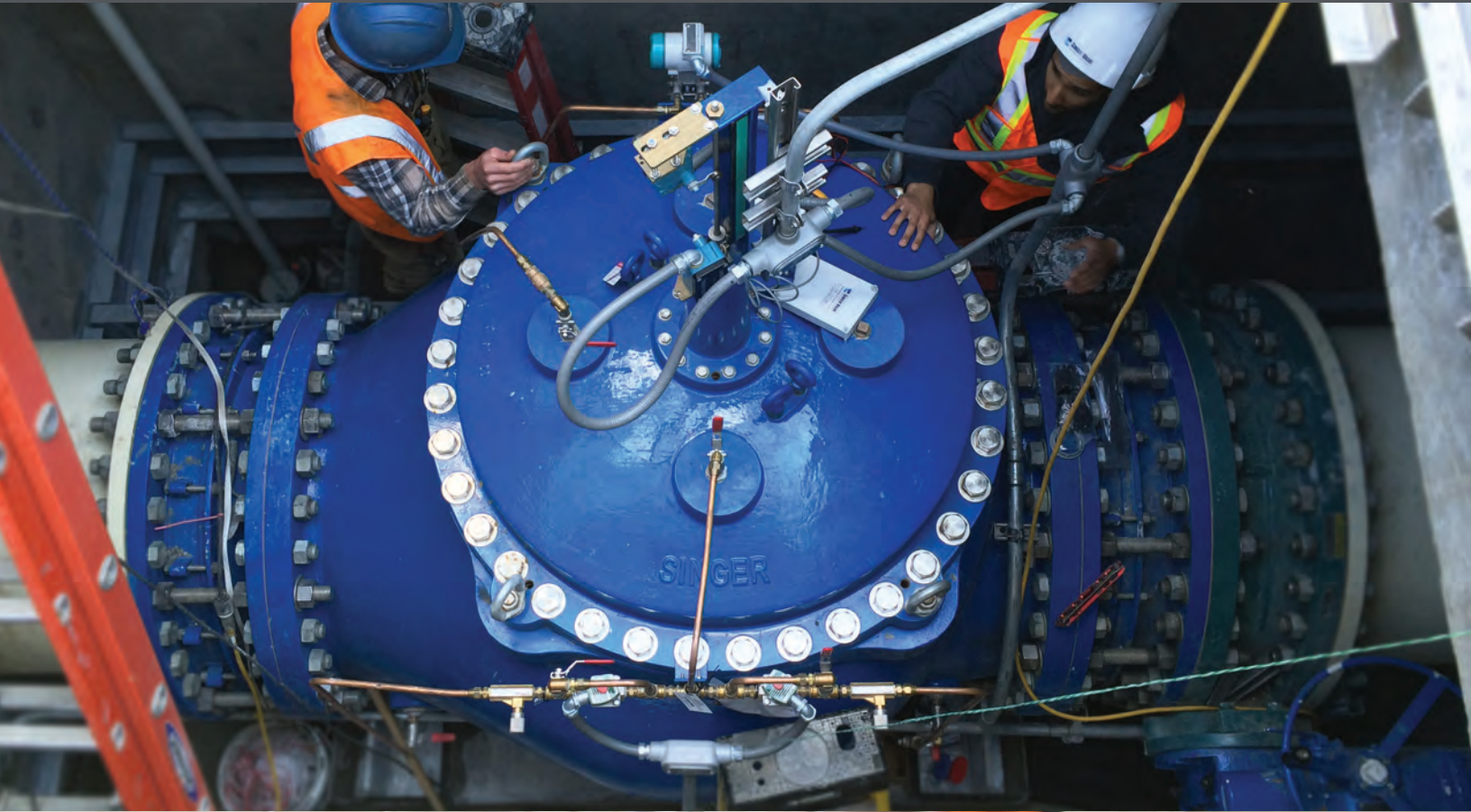

FLOW CONTROL VALVES

Want to allow flow to meet a predetermined demand? How about limiting the flow to a pre-set maximum? Or, preventing water loss from a catastrophic downstream pipe break? Never fear. Our flow control valves are here.

MODELS 106-RF / 206-RF

Flow Limiting Control Valve

KEY FEATURES

- Accurately limits flow to a pre-set maximum
- Easily adjustable flow limit
- Paddle-style orifice plate included
- Optional orifice plate housing

PRODUCT OVERVIEW

The 106-RF and 206-RF flow limiting control valves are based on the 106-PG or 206-PG main valves. The valve is ideal for limiting the flow to a pre-determined maximum (via maintaining a continuous pressure differential across an orifice).

When the pressure differential is less than the set-point, the valve opens, allowing flow to meet pre-determined demand. At the desired maximum set-point, the pilot reacts to small changes in sensing pressure and controls the main valve position by modulating the pressure above the diaphragm.

When the pressure drop across the orifice exceeds the set-point, the valve closes slightly, limiting the flow to the pre-set maximum. The orifice is usually sized to generate a pressure differential of 3 to 5 psi / 0.2 to 0.35 bar at the desired flow. Adjusting the pilot setting permits the maximum flow to be changed in the field above or below the original point.



TYPICAL APPLICATION

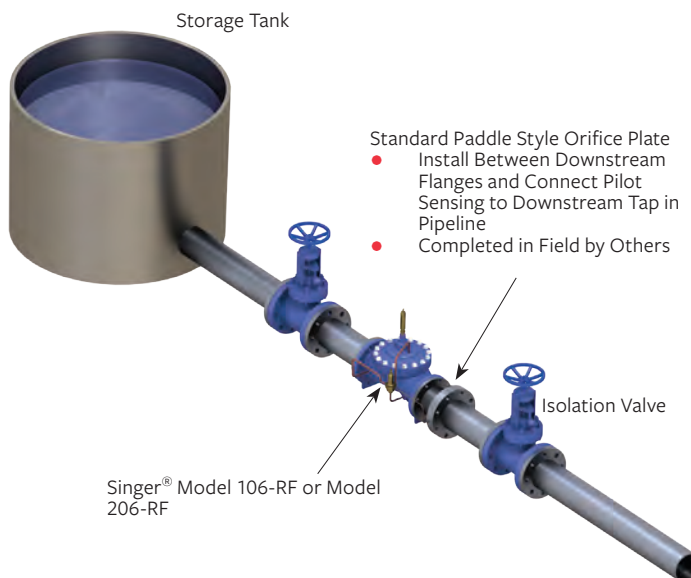

MODELS 106-RF / 206-RF

Flow Limiting Control Valve

SCHEMATIC DRAWING

NO.	PART
1	Main Valve - 106-PG or 206-PG with X107 Position Indicator
2	Isolation Valves (2A, 2B, 2C) Standard
3	Strainer - 40 Mesh - Standard on All Sizes
4	Model 26 Flow Stabilizer Standard on Valves 8" / 200 mm 106, 10" / 250 mm 206
5	Fixed Restriction
6	Orifice Plate - Paddle Style - Fits Inside Bolt Pattern
7	Model 160-RF Rate of Flow Pilot - Specify for 2 to 20 psi / 0.138 to 1.38 bar; 25 to 50 psi / 1.72 to 3.4 bar
8	1/2" / 15 mm Ball Valve and Flare fittings - for Downstream Connection of Sensing Line to Header - Field Install
9	3/8" / 10 mm Sensing Tubing - Supply and Installation by Others
10	Optional: Closing Speed Control - Model 852-B
11	Optional: Orifice Plate and Housing Assembly (Not Shown)

Note: SRD shown is available for 6" 106-PG and larger.

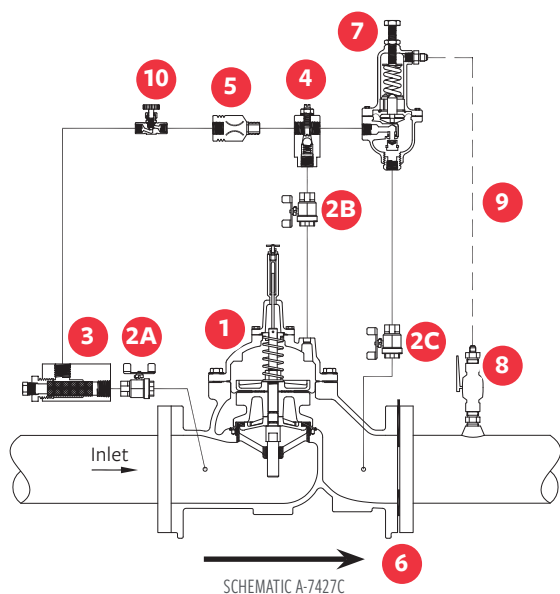

When the optional orifice plate and housing assembly (item 11) is included, the overall laying length of the valve assembly increases. Add 1 1/4" / 32 mm to the published 'A' dimension for the valve model and size. The assembly is provided with a full face gasket, but bolts, nuts and washers are to be provided by others.

STANDARD MATERIALS

Standard materials for pilot system components are:

- ASTM B62 bronze or ASTM B-16 brass
- Stainless steel
- Copper

SELECTION SUMMARY

1. Determine the flow range and limit (setting) for the application - standard range 2:1 - maximum to minimum.
2. Determine the pressure drop available to provide control at the flow limit - valve plus orifice losses.
3. For the most positive control, the orifice is sized in combination with the valve to use the full pressure drop available at the maximum flow setting.
4. To calculate the pressure drop across the orifice, use the formula $P = 3 \text{ psi } (Q_{\text{max}}/Q_{\text{min}})^2$. 3 psi / 0.2 bar is a standard minimum but 2 psi / 0.138 bar is acceptable if necessary. With the orifice plate designed for a 2:1 flow adjustment range, the orifice loss would then range from 3 to 12 psi / 0.2 to 0.8 bar.
5. Use the performance curves (see Technical & Sizing Information section, page 231, and/or the chart above, to determine the valve size with sufficient capacity, with the pressure drop available. Consult with us for precise orifice plate calculations.

ORDERING INSTRUCTIONS

Refer to page 244 for the order form and ordering instructions. Additionally, include the following information for this product:

1. Single chamber (106) or (206)
2. Pilot range

MODELS 106-RF / 206-RF

Flow Limiting Control Valve

106-RF

FLOW COEFFICIENT

(SEE 106-PG IN MAIN VALVE SECTION FOR OTHER VALVE DATA)

Size (Inches)	½"	¾"	1"	1 ¼"	1 ½"	2"	2 ½"	3"	4"
Size (mm)	15 mm	19 mm	25 mm	32 mm	40 mm	50 mm	65 mm	80 mm	100 mm
Maximum Continuous (USGPM)	Not available in these sizes				125	210	300	460	800
Maximum Continuous (L/s)	Not available in these sizes				8	13	19	29	50

106-RF

FLOW CAPACITY

(SEE 106-PG IN MAIN VALVE SECTION FOR OTHER VALVE DATA)

Size (Inches)	6"	8"	10"	12"	14"	16"	20"	24"	36"
Size (mm)	150 mm	200 mm	250 mm	300 mm	350 mm	400 mm	500 mm	600 mm	900 mm
Maximum Continuous (USGPM)	1800	3100	4900	7000	8500	11000	17500	25000	55475
Maximum Continuous (L/s)	114	196	309	442	536	694	1104	1577	3500

206-RF

FLOW COEFFICIENT C_v

(SEE 206-PG IN MAIN VALVE SECTION FOR OTHER VALVE DATA)

Size (Inches)	3"	4"	6"	8"	10"	12"	16"	18"	20"
Size (mm)	80 mm	100 mm	150 mm	200 mm	250 mm	300 mm	400 mm	450 mm	500 mm
Maximum Continuous (USGPM)	300	580	1025	2300	4100	6400	9230	16500	16500
Maximum Continuous (L/s)	19	37	65	145	260	404	582	1040	1040

206-RF

FLOW CAPACITY

(SEE 206-PG IN MAIN VALVE SECTION FOR OTHER VALVE DATA)

Size (Inches)	24 x 16"	24 x 20"	28"	30"	32"	36"	40"	48"
Size (mm)	600 x 400 mm	600 x 500 mm	700 mm	750 mm	800 mm	900 mm	1000 mm	1200 mm
Maximum Continuous (USGPM)	16500	21700	33600	33650	33700	33800	55475	55475
Maximum Continuous (L/s)	1040	1370	2120	2123	2126	2132	3500	3500

MODELS 106-EF-8837BX / 206-EF-8837BX

Excess Flow (Burst Control) Valve

KEY FEATURES

- Tight shut-off when flow exceeds a pre-determined amount
- Manual re-activation required after failure
- “Failure Signal” options available

PRODUCT OVERVIEW

The 106-EF-8837BX and 206-EF-8837BX excess flow valves are based on the 106-PT and 206-PT Double Chamber main valves. The valve is designed to shut-off tightly when flow exceeds a pre-determined amount.

The 625-RPD pilot senses the pressure drop of the valve and closes the valve when the tripping flow is reached. Typical pressure drop at tripping is 5 psi / 0.35 bar.

Tripping flow is adjusted by limiting the valve opening with the X102 Stroke Limiter. 10 psi / 0.7 bar inlet pressure must be maintained at the valve inlet when the valve has tripped to prevent self re-setting. This valve closes fast and from a significant velocity. If the upstream pipe is longer than 2,000' / 600 m, closing speed control should be included. When tripped (closed), this valve has continuous exhaust of about 1 GPM / 0.063 L/sec to drain.



TYPICAL APPLICATION

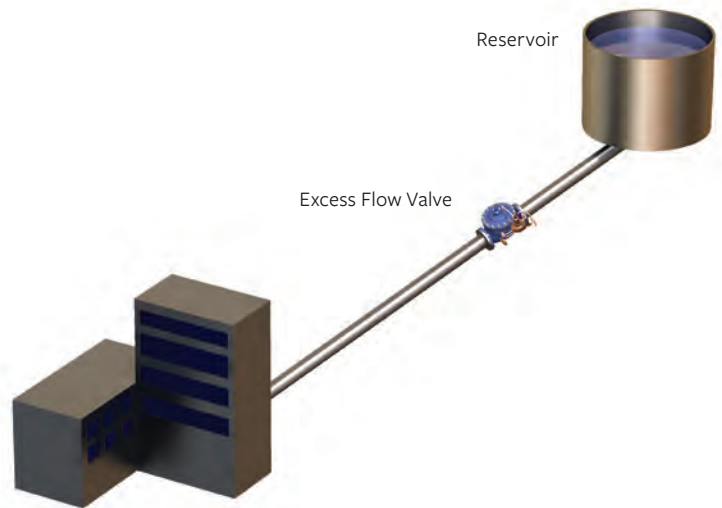

MODELS 106-EF-8837BX / 206-EF-8837BX

Excess Flow (Burst Control) Valve

SCHEMATIC DRAWING

NO.	PART
1	Model 106-PT-EF / 206-PT-EF Main Valve c/w X102 Stroke Limiter
2	Strainer
3	Model 625-RPD Normally Closed Pilot
4	Fixed Restriction - 1/16" / 1.6 mm (4A, 4B)
5	Check Valve

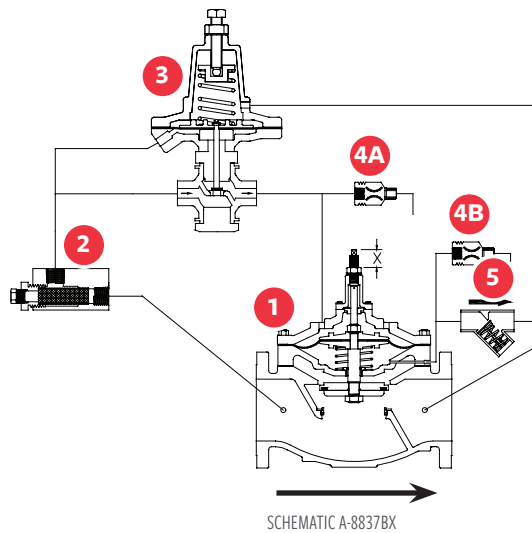

SELECTION SUMMARY

1. Confirm that the application calls for a valve that closes and remains closed if the flow momentarily exceeds the set-point, regardless of what the cause of the high flow is.
2. Using sizing charts for fully open valves, select a valve size and model that has a higher flow at 5 psi / 0.345 bar pressure drop than any anticipated tripping flow. Consider both 106 and 206 style valves. Avoid over-sizing.
3. Remember that this valve closes fast and from a significant velocity. Closing Speed Control may be required.
4. A drain may be required in chamber due to continuous exhaust when valve has tripped.
5. Ensure that flange pressure rating exceeds maximum operating pressure.

ORDERING INSTRUCTIONS

Refer to page 244 for the order form and ordering instructions.

Additionally, include the following information for this product:

Tripping flow

MODELS 106-EF-8837BX / 206-EF-8837BX

Excess Flow (Burst Control) Valve

106-EF

FLOW CAPACITY

(SEE 106-PT IN MAIN VALVE SECTION FOR OTHER VALVE DATA)

Size (Inches)	3"	4"	6"	8"	10"
Size (mm)	80 mm	100 mm	150 mm	200 mm	250 mm
Maximum tripping (USGPM)	250	440	1000	1700	2700
Maximum tripping (L/s)	16	28	63	107	170

206-EF

FLOW CAPACITY

(SEE 206-PT IN MAIN VALVE SECTION FOR OTHER VALVE DATA)

Size (Inches)	3"	4"	6"	8"	10"	12"
Size (mm)	80 mm	100 mm	150 mm	200 mm	250 mm	300 mm
Maximum tripping (USGPM)	135	320	560	1100	2200	3400
Maximum tripping (L/s)	9	20	35	69	139	215



ELECTRONIC CONTROL

The secret of many of our valve solutions lies with their electronic control capability. Whether it's through radio, direct wire connections, cellular networks, satellite or telephone lines, our electronic control management products interface seamlessly and effortlessly with SCADA. Have a single process application? Need to control multiple processes? We customize solutions to meet the demands of unique applications.

For complete specifications on electronics products, please refer to the Electronic Control Solutions Catalogue.

MODELS 106-SC / 206-SC

Solenoid Control Valve

KEY FEATURES

- Positive, drip-tight shut-off
- Simple, on-off operation
- Globe or angle style body

PRODUCT OVERVIEW

Singer® models 106-SC and 206-SC solenoid control valves are based on the Singer model 106-PG or 206-PG main valve. The solenoid control valve provides on-off position operation. The solenoid either admits inlet pressure into the main valve operating chamber or releases pressure from the operating chamber. The pilot system is usually piped to discharge at the valve outlet, but can be piped to discharge to drain (atmosphere). This valve is available either with the main valve closed when the solenoid is de-energized (NC - Normally Closed) or with the main valve open when the solenoid is de-energized (NO - Normally Open). (NC or NO refers to the main valve, not the solenoid.)

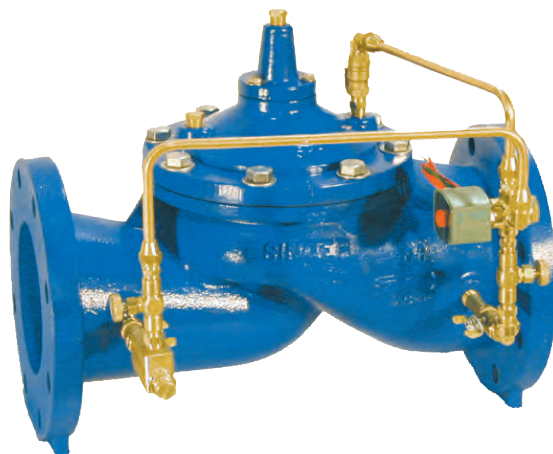

TYPICAL APPLICATION

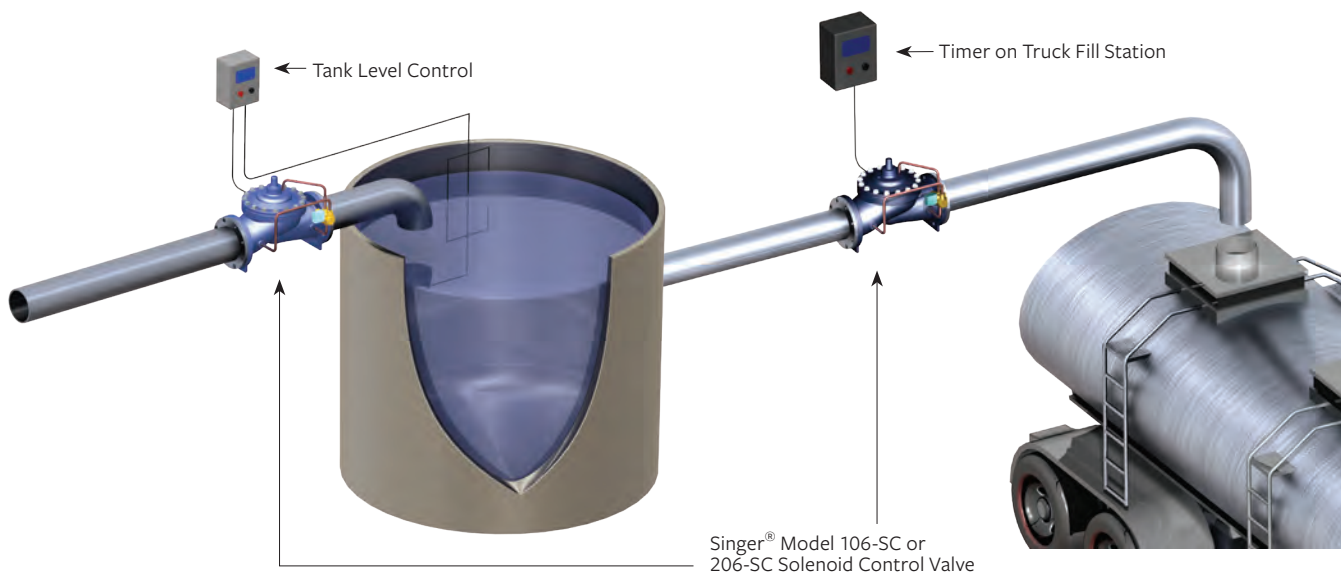

MODELS 106-SC / 206-SC

Solenoid Control Valve

SCHEMATIC DRAWING

NO.	PART
1	Main Valve - 106-PG or 206-PG
2	Isolating Valves - (2A, 2B, 2C - (Optional on 3" / 80 mm and Smaller).
3	Strainer - 40 Mesh Stainless Steel Screen
4	Closing Speed Control - Model 852-B (Optional on 3" / 80 mm and Smaller).
5	Solenoid Pilot Valve - 3 Way - 120 VAC / 60 Hz Standard, Other Voltages Available
6	Opening Speed Control - Model 852-B (Optional on 3" / 80 mm and Smaller).

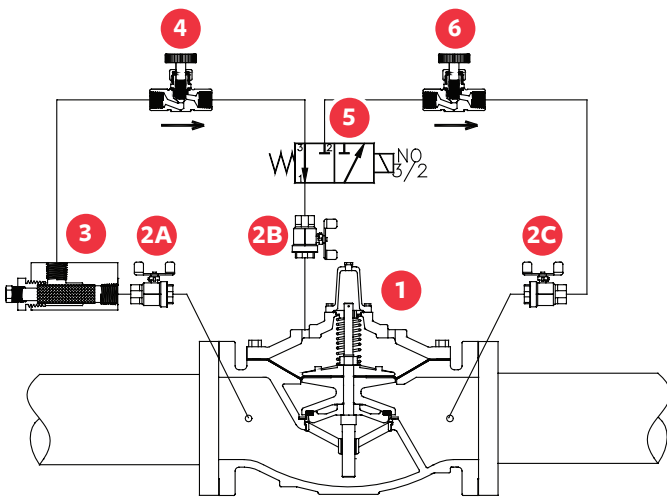

SCHEMATIC A-0593C

STANDARD MATERIALS

Standard materials for pilot system components are:

- ASTM B62 bronze or ASTM B-16 brass
- Stainless steel trim
- Standard solenoid coil is rated as NEMA 1, 2, 3, 3S, 4 and 4X, combination general purpose and watertight
- Other voltages, ratings and constructions are available, consult with us.

SELECTION SUMMARY

1. Select the valve with sufficient capacity, using the allowable operating pressure drop across the valve.
2. If the outlet pressure is less than 35% of the inlet pressure, check for cavitation.
3. Ensure the maximum working pressure rating of the valve exceeds the maximum operating pressure.
4. Continuous, "C", service up to 20 ft /s / 6 m/s is generally suitable. Refer to chart and/or performance curves (see Technical & Sizing Information section, page 231).
5. Provide system maximum and minimum operating pressures, electrical voltage, etc for correct solenoid selection.
6. If control fluid is from a separate source, provide us with details.
 - For valve positioning - process control, see section 2SC-PCO, Dual Solenoid Control Valve, page 185.
 - For two (2) stage opening or closing, consult with us.
 - Most pilot functions may be combined with the model SC, consult with us.

ORDERING INSTRUCTIONS

Refer to page 244 for the order form and ordering instructions.

1. Single chamber (106) or (206)
2. Solenoid voltage
3. Energize or de-energize solenoid to close main valve

MODELS 106-SC / 206-SC

Solenoid Control Valve

106-SC

FLOW CAPACITY (SEE 106-PG IN MAIN VALVE SECTION FOR OTHER VALVE DATA)

Size (Inches)	½"	¾"	1"	1 ¼"	1 ½"	2"	2 ½"	3"	4"
Size (mm)	15 mm	19 mm	25 mm	32 mm	40 mm	50 mm	65 mm	75 mm	100 mm
Minimum (USGPM) Flat Diaphragm	1	1	1	1	1	5	5	5	10
Minimum (L/s) Flat Diaphragm	0.1	0.1	0.1	0.1	0.1	0.3	0.3	0.3	0.6
Maximum Continuous (USGPM)	12	19	49	93	125	210	300	460	800
Maximum Continuous (L/s)	0.8	1	3	6	8	13	19	29	50

106-SC

FLOW CAPACITY (SEE 106-PG IN MAIN VALVE SECTION FOR OTHER VALVE DATA)

Size (Inches)	6"	8"	10"	12"	14"	16"	20"	24"	36"
Size (mm)	150 mm	200 mm	250 mm	300 mm	350 mm	400 mm	500 mm	600 mm	900 mm
Minimum (USGPM) Flat Diaphragm	20	40	-	-	-	-	-	-	-
Minimum (USGPM) Rolling Diaphragm	1	1	3	3	3	3	10	10	20
Minimum (L/s) Flat Diaphragm	1.3	2.5	-	-	-	-	-	-	-
Minimum (L/s) Rolling Diaphragm	0.1	0.1	0.2	0.2	0.2	0.2	0.6	0.6	1.3
Maximum Continuous (USGPM)	1800	3100	4900	7000	8500	11000	17500	25000	55475
Maximum Continuous (L/s)	114	196	309	442	536	694	1104	1577	3500

206-SC

FLOW CAPACITY (SEE 206-PG IN MAIN VALVE SECTION FOR OTHER VALVE DATA)

Size (Inches)	3"	4"	6"	8"	10"	12"	16"	18"	20"
Size (mm)	80 mm	100 mm	150 mm	200 mm	250 mm	300 mm	400 mm	450 mm	500 mm
Minimum (USGPM) Flat Diaphragm	5	5	10	20	40	-	-	-	-
Minimum (USGPM) Rolling Diaphragm	-	-	-	-	-	3	3	3	3
Minimum (L/s) Flat Diaphragm	0.3	0.3	0.6	1.3	2.5	-	-	-	-
Minimum (L/s) Rolling Diaphragm	-	-	-	-	-	0.2	0.2	0.2	0.2
Maximum Continuous (USGPM)	300	580	1025	2300	4100	6400	9230	16500	16500
Maximum Continuous (L/s)	19	37	65	145	260	404	582	1040	1040

206-SC

FLOW CAPACITY (SEE 206-PG IN MAIN VALVE SECTION FOR OTHER VALVE DATA)

Size (Inches)	24 x 16"	24 x 20"	28"	30"	32"	36"	40"	48"
Size (mm)	600 x 400 mm	600 x 500 mm	700 mm	750 mm	800 mm	900 mm	1000 mm	1200 mm
Minimum (USGPM) Flat Diaphragm	3	3	10	10	10	10	20	20
Minimum (L/s) Flat Diaphragm	0.2	0.2	0.6	0.6	0.6	0.6	1.3	1.3
Maximum Continuous (USGPM)	16500	21700	33600	33650	33700	33800	55475	55475
Maximum Continuous (L/s)	1040	1370	2120	2123	2126	2132	3500	3500

MODELS 106-2SC-PCO / 206-2SC-PCO

Dual Solenoid Control for Positioning and SCADA Controls

KEY FEATURES

- Precise control from remote locations
- Process controller compatible
- Minimal power needed for stand-by operation
- Complete service in-line
- Manual controls for emergencies

PRODUCT OVERVIEW

The Singer® models 106-2SC-PCO and 206-2SC-PCO dual solenoid electronic valves are based on the Singer model 106-PG or 206-PG main valve.

The flow into and out of the upper operating chamber is controlled by the two pilot solenoids. The electronic control determines whether the opening solenoid or the closing solenoid is operated. The change in valve position is dependent upon which solenoid is operated and the duration of the energized period.

The electronic control determines the valve function. Virtually any hydraulic function can be achieved using the “open-close” output from the SCADA controller to the valve.

The Singer Model 2SC-PCO is designed for use with Singer MCP Multi-Process Control Panel or the EPC Single-Process Control Panel.

TYPICAL APPLICATION

The two pilot solenoids are operated to keep two independent signals matched. In this case, the valve is operated to ensure the “process variable signal” follows the “SCADA set-point command signal”.

Typically this mode is used when the process variable signal is from a flow meter, pressure sensor or similarly quick changing process. This is referred to as “set-point control”.

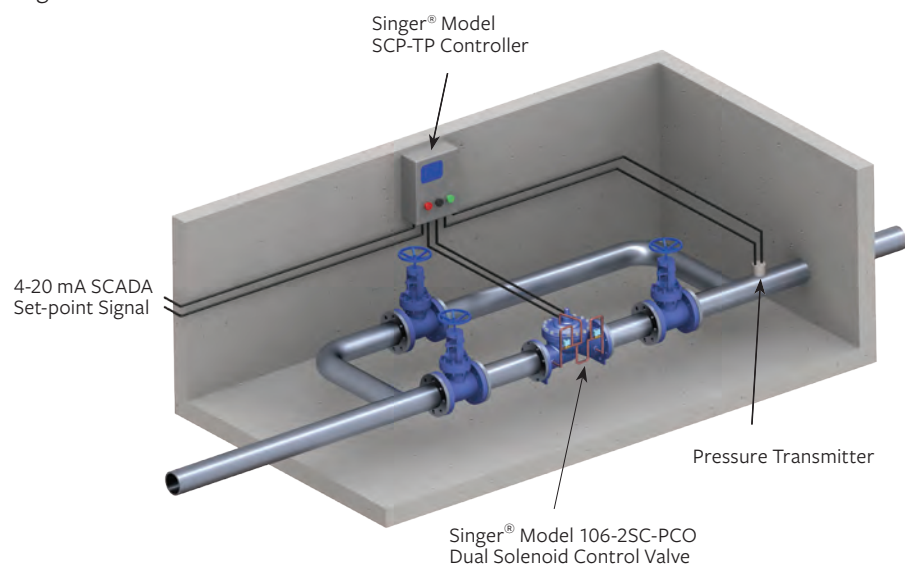

MODELS 106-2SC-PCO / 206-2SC-PCO

Dual Solenoid Control For Positioning and Scada Controls

SCHEMATIC DRAWING

NO.	PART
1	Main Valve - 106-PG or 206-PG
2	Isolating Valves - (2A, 2B, 2C)
3	Strainer - 40 Mesh Stainless Steel Screen
4	Closing Speed Control - Micrometer Needle Valve
5	Closing Solenoid Pilot Valve - 120 VAC / 60 Hz Standard, Other Voltages Available
6	Opening Solenoid Pilot Valve - 120 VAC / 60 Hz Standard, Other Voltages Available
7	Manual Closing Bypass
8	Manual Opening Bypass
9	Opening Speed Control - Micrometer Needle Valve
10	*Optional X156 Analog Position Transmitter (4 to 20 mA)

***Note:** All 106 series 2 1/2" / 65 mm to 4" / 100 mm and all 206 series 4" / 100 mm to 6" / 150 mm will be fitted with heavy springs. SRD shown is available for 6" 106-PG and larger.

Note: SRD shown is available for 6" 106-PG and larger.

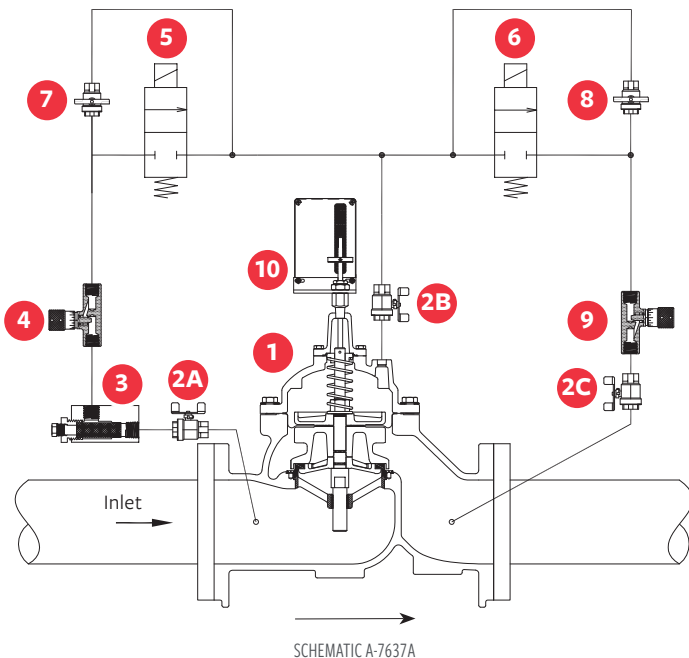

STANDARD MATERIALS

Standard materials for pilot system components are:

- ASTM B62 bronze or ASTM B-16 brass
- Stainless steel trim
- Standard solenoid coil is rated as NEMA 1, 2, 3, 3S, 4 and 4X, combination general purpose and watertight
- Other voltages, ratings and constructions are available, consult with us.

SELECTION SUMMARY

1. Select a valve with sufficient capacity, using the allowable operating pressure drop across the valve.
2. Usually operating in the continuous, "C", service range up to 20 ft / s / 6 m/s - (refer Technical & Sizing Section, page 231).
3. If the outlet pressure is less than 35% of the inlet pressure, check for cavitation.
4. Ensure the max working pressure rating of the valve exceeds the max operating pressure.
5. Ensure the solenoid coils are compatible with the electronic controllers - 120 VAC / 60 Hz standard.
6. Verify that the electronic controls are properly configured to provide the functions required.
 - For compatible electronic controls, refer to Singer® Process Control Panels, pages 203, 204
 - For applications requiring high pressure drops, refer to Singer model 106-AC, page 78.
 - Standard hydraulic pilots can provide back-up control should the system go off limits
 - For applications where electric service and electronic controls are unsuitable, refer to the standard hydraulic model
 - Addition of Position Transmitter and Differential Pressure Transmitter or SPI-MV are required for metering function.

MODELS 106-2SC-PCO / 206-2SC-PCO

Dual Solenoid Control For Positioning and Scada Controls

ORDERING INSTRUCTIONS

Refer to page 244 for the order form and ordering instructions.

1. Single chamber (106) or (206)
2. Inlet / outlet pressure range
3. Solenoid voltage
4. Standard power failure mode is fail at last position – specify options

Fail open on power failure

Fail close on power failure

106-2SC-PCO

FLOW CAPACITY (SEE 106-PG IN MAIN VALVE SECTION FOR OTHER VALVE DATA)

Size (Inches)	2 1/2"	3"	4"	6"	8"	10"	12"	14"	16"	20"	24"	36"
Size (mm)	65 mm	80 mm	100 mm	150 mm	200 mm	250 mm	300 mm	350 mm	400 mm	500 mm	600 mm	900 mm
Minimum (USGPM) Flat Diaphragm	CF	CF	10	20	40	-	-	-	-	-	-	-
Minimum (USGPM) Rolling Diaphragm	-	-	-	1	1	3	3	3	3	10	10	20
Minimum (L/s) Flat Diaphragm	CF	CF	0.63	1.26	2.52	-	-	-	-	-	-	-
Minimum (L/s) Rolling Diaphragm	-	-	-	0.1	0.1	0.2	0.2	0.2	0.2	0.6	0.6	1.3
Maximum Continuous (USGPM)	CF	CF	800	1800	3100	4900	7000	8500	11000	17500	25000	55475
Maximum Continuous (L/s)	CF	CF	50	114	196	309	442	536	694	1104	1577	3500

206-2SC-PCO

FLOW CAPACITY (SEE 206-PG IN MAIN VALVE SECTION FOR OTHER VALVE DATA)

Size (Inches)	3"	4"	6"	8"	10"	12"	16"	18"	20"	24 x 16"	24 x 20"	28"	30"	32"	36"	40"	48"
Size (mm)	80 mm	100 mm	150 mm	200 mm	250 mm	300 mm	400 mm	450 mm	500 mm	600 x 400 mm	600 x 500 mm	700 mm	750 mm	800 mm	900 mm	1000 mm	1200 mm
Minimum (USGPM) Flat Diaphragm	CF	5	10	20	40	-	-	-	-	-	-	-	-	-	-	-	-
Minimum (USGPM) Rolling Diaphragm	-	-	-	-	-	3	3	3	3	3	3	10	10	10	10	20	20
Minimum (L/s) Flat Diaphragm	CF	0.3	0.6	1.3	2.5	-	-	-	-	-	-	-	-	-	-	-	-
Minimum (L/s) Rolling Diaphragm	-	-	-	-	-	0.19	0.19	0.19	0.19	0.19	0.19	0.63	0.63	0.63	0.63	1.3	1.3
Maximum Continuous (USGPM)	CF	580	1025	2300	4100	6400	9230	16500	16500	16500	21700	33600	33650	33700	33800	55475	55475
Maximum Continuous (L/s)	CF	37	65	145	260	404	582	1040	1040	1040	1370	2120	2123	2126	2132	3500	3500

Note: CF = Consult us on all sizes 3" (80 mm) and under

MODELS 106 2PR-SC-BT / 206 2PR-SC-BT

Dual Adjustable Set Point Pressure Reducing Valve Using Solenoid Control

KEY FEATURES

- Two Adjustable Outlet Pressure Set Points (Daytime / Night)
- Selectable Using Battery Operated Control
- Pressure Reducing Valve with two set points, high pressure and low pressure
- Time-based selection via latching solenoid and timer
- Self-contained, powered by a 9-volt battery (1 controller, 1 programmer)
- 24/7 time settings (can skip days)
- Multiple time selection possible (up to 10 time settings per 24 hour period)
- Reduces system pressure when not needed (low flow demand or night time), supplies increased pressure when required (high flow demand or day time)
- Recommended for systems where no external power source is available



PRODUCT OVERVIEW

The 106 2PR-SC-BT and 206 2PR-SC-BT dual adjustable set point pressure reducing valve using solenoid control is based on the 106-PG or 206-PG valve. The valve is installed with two PR pressure reducing pilots, one set to low pressure, the other to high pressure. The pilot senses the downstream pressure through a connection to the valve outlet. Under flowing conditions, the pilot reacts to small changes in pressure to control the valve position by modulating relatively steady as the pilot set points. The high pressure pilot can be isolated by means of a battery operated latching solenoid. This solenoid is controlled using a fully programmable controlled which is user set to give higher and lower pressure based on time. The solenoid is energized to open and switch to the high pressure pilot from the normal low pressure pilot setting.

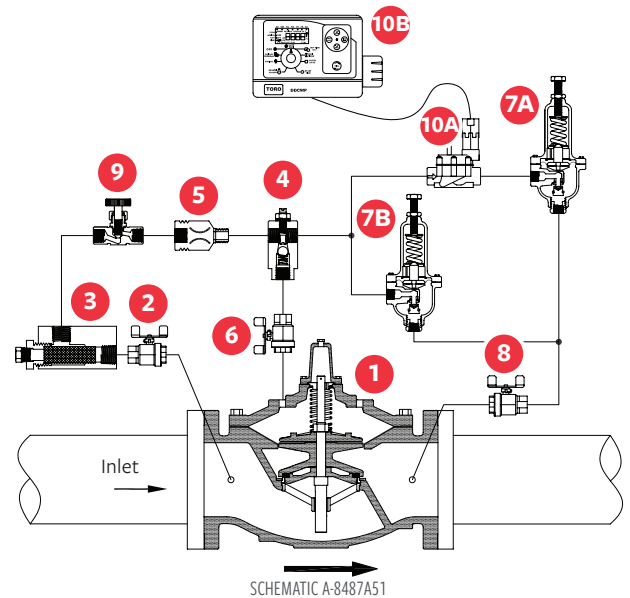

SCHEMATIC DRAWING

NO.	PART
1	Main Valve - 106-PG or 206-PG
2	Isolating Valve
3	Strainer
4	Model 26 Flow Stabilizer / Opening Speed Control Standard (106 or 206) on Flat Diaphragm Optional on Rolling (S106 or S206) Diaphragm valves

NO.	PART
5	Fixed Restriction
6	Isolation Valve
7	Pressure Reducing Pilot - 160 model
7A	High Setting
7B	Low Setting
8	Isolation Valve
9	Closing speed control - Model 852-B - Optional
10	Solenoid Valve and Controller
10A	Low Flow Valve with Potted Latching Solenoid
10B	Control Module with Bracket, 9VDC

MODELS 106 2PR-SC-BT / 206 2PR-SC-BT

Dual Adjustable Set Point Pressure Reducing Valve Using Solenoid Control

STANDARD MATERIALS

Standard materials for pilot system components are:

- ASTM B62 bronze or ASTM B16 brass
- AISI 303/316 stainless steel trim
- Buna-N / EPDM diaphragm and seals

SELECTION SUMMARY

- Select the valve series and size with sufficient capacity.
- Check the operating flow against valve minimum.

- If the outlet pressure is less than 35% of the inlet pressure, check for cavitation.
- Ensure that the flange rating exceeds the maximum operating pressure.

ORDERING INSTRUCTIONS

Refer to page 244 for the order form and ordering instructions.

Additionally, include the following information for this product:

1. Single chamber (106) or (206)
2. Pilot range

106-PR-SC

FLOW CAPACITY (SEE 106-PG IN MAIN VALVE SECTION FOR OTHER VALVE DATA)

Size (Inches)	1/2"	3/4"	1"	1 1/4"	1 1/2"	2"	2 1/2"	3"	4"
Size (mm)	15 mm	19 mm	25 mm	32 mm	40 mm	50 mm	65 mm	75 mm	100 mm
Minimum (USGPM) Flat Diaphragm	1	1	1	1	1	5	5	5	10
Minimum (L/s) Flat Diaphragm	0.1	0.1	0.1	0.1	0.1	0.3	0.3	0.3	6
Maximum Continuous (USGPM)	12	19	49	93	125	210	300	460	800
Maximum Continuous (L/s)	0.8	1	3	6	8	13	19	29	50

106-PR-SC

FLOW CAPACITY (SEE 106-PG IN MAIN VALVE SECTION FOR OTHER VALVE DATA)

Size (Inches)	6"	8"	10"	12"	14"	16"	20"	24"	36"
Size (mm)	150 mm	200 mm	250 mm	300 mm	350 mm	400 mm	500 mm	600 mm	900 mm
Minimum (USGPM) Flat Diaphragm	20	40	-	-	-	-	-	-	-
Minimum (USGPM) Rolling Diaphragm	1	1	3	3	3	3	10	10	20
Minimum (L/s) Flat Diaphragm	1.3	2.5	-	-	-	-	-	-	-
Minimum (L/s) Rolling Diaphragm	0.1	0.1	0.2	0.2	0.2	0.2	0.6	0.6	1.3
Maximum Continuous (USGPM)	1800	3100	4900	7000	8500	11000	17500	25000	55470
Maximum Continuous (L/s)	114	196	309	442	536	694	1104	1577	3500

206-SC

FLOW CAPACITY (SEE 206-PG IN MAIN VALVE SECTION FOR OTHER VALVE DATA)

Size (Inches)	3"	4"	6"	8"	10"	12"	16"	18"	20"
Size (mm)	80 mm	100 mm	150 mm	200 mm	250 mm	300 mm	400 mm	450 mm	500 mm
Minimum (USGPM) Flat Diaphragm	5	5	10	20	40	-	-	-	-
Minimum (USGPM) Rolling Diaphragm	-	-	-	-	-	3	3	3	3
Minimum (L/s) Flat Diaphragm	0.3	0.3	0.6	1.3	2.5	-	-	-	-
Minimum (L/s) Rolling Diaphragm	-	-	-	-	-	0.2	0.2	0.2	0.2
Maximum Continuous (USGPM)	300	580	1025	2300	4100	6400	9230	16500	16500
Maximum Continuous (L/s)	19	37	65	145	260	404	582	1040	1040

206-SC

FLOW CAPACITY (SEE 206-PG IN MAIN VALVE SECTION FOR OTHER VALVE DATA)

Size (Inches)	24 x 16"	24 x 20"	28"	30"	32"	36"	40"	48"
Size (mm)	600 x 400 mm	600 x 500 mm	700 mm	750 mm	800 mm	900 mm	1000 mm	1200 mm
Minimum (USGPM) Flat Diaphragm	3	3	10	10	10	10	20	20
Minimum (L/s) Flat Diaphragm	0.2	0.2	0.6	0.6	0.6	0.6	1.3	1.3
Maximum Continuous (USGPM)	16500	21700	33600	33650	33700	33800	55475	55475
Maximum Continuous (L/s)	1040	1370	2120	2123	2126	2132	3500	3500

MODEL 106-SPI-MV

Single Point Insertion Flow Metering Valve

KEY FEATURES

- Accurate flow metering, combined with control valve to save space / cost
- Supplied with Flow Converter for local display with 4-20 mA output measurement or can be combined with PLC-based control panel for flow control applications
- +/- 2% of rate accuracy, NIST traceable

PRODUCT OVERVIEW

The Singer® Model 106-SPI-MV is a Single Point Insertion Electromagnetic Flow Meter, installed and calibrated in conjunction with a Singer® valve to provide an accurate flow rate that can be utilized with the metering valve as a stand alone option or built into a 106-2SC-PCO pilot system to provide complete flow-based valve control.

The sensor is available for one-inch taps, depending upon valve size and application.

The compact insertion design fits in confined spaces and offers complete accessibility. The flow meter can be removed for easy inspection, cleaning, calibrating or verification.

This cost effective flow meter option is available for valve sizes from 3" (80 mm) to 36" (900 mm) inches. The flow sensor comes pre-calibrated from McCrometer's NIST traceable Calibration Lab and requires no recalibration in the field. With no moving parts and a single-piece design, the SPI Mag's sensor contains nothing to wear or break, and it is generally immune to clogging by sand, grit or other debris.

The 106-SPI-MV Mag is profiled for the valve body, further enhancing its measurement accuracy by allowing precise determination of mean velocities.



SCHEMATIC DRAWING

NO.	PART
1	Main Valve - Model 106-PG
2	Model SPI - Single Point Insertion Meter
3	Local Converter - Flow Indicating Transmitter

Note: Local IP67 Converter is standard.

Optional enclosures are:

- Stainless Steel IP66 - NEMA 4 - Panel Mounted (optional)
- Fibreglass NEMA 4X - Panel Mounted (optional)
- SS IP66 - NEMA 4X - Panel Mounted (optional)
- Polycarbonate IP67 NEMA 6 - Panel Mounted (optional)

MODEL 106-SPI-MV

Single Point Insertion Flow Metering Valve

STANDARD MATERIALS

Standard materials for pilot system components are:

- IP67 Die cast aluminum - Local
- SS IP66 - NEMA 4 - Panel Mounted (optional)
- Fibreglass NEMA 4X - Panel Mounted (optional)
- Polycarbonate IP67 NEMA 6 - Panel Mounted (optional)

SELECTION SUMMARY

1. Allow 3 pipe diameters minimum upstream of sensor
2. These units can be installed with Singer® AC (Anti-Cav) cages
3. Sensor can be installed on either side of valve- inlet only

ORDERING INSTRUCTIONS

Refer to page 245 for the order form.

Please be prepared to provide the following information:

- Valve size
- Pressure
- Minimum flow
- Fluid
- Cable length
- Temperature

106-SPI-MV

FLOW CAPACITY (SEE 106-PG IN MAIN VALVE SECTION FOR OTHER VALVE DATA)

Size (Inches)	3"	4"	6"	8"	10"	12"	16"	20"	24"	28"	36"
Size (mm)	80 mm	100 mm	150 mm	200 mm	250 mm	300 mm	400 mm	500 mm	600 mm	700 mm	900 mm
Minimum (USGPM) Flat Diaphragm	5	10	20	40	-	-	-	-	-	-	-
Minimum (USGPM) Rolling Diaphragm	-	-	0.5	1	3	3	3	10	10	10	20
Minimum (L/s) Flat Diaphragm	0.3	0.6	-	-	-	-	-	-	-	-	-
Minimum (L/s) Rolling Diaphragm	-	-	0.03	0.06	0.2	0.2	0.2	0.6	0.6	0.6	1.3
Maximum Continuous (USGPM)	460	800	1,800	3,100	4,900	7,000	11,000	17,500	25,000	33,600	55,470
Maximum Continuous (L/s)	29	50	114	196	309	442	694	1,104	1,577	2,120	3,500

MODELS 106-2SC-MV / 206 2SC-MV

Electronic Flow Control and Metering Valve

KEY FEATURES

- Combines precise flow control with relatively accurate flow metering, save space / cost
- PLC-based control panel is compatible with your SCADA system
- Manual control is available in case of emergencies
- Re-transmission capabilities
- Can be field retrofitted to existing valves
- +/- 3% accuracy, certified by NIST approved testing laboratory (on select sizes)

PRODUCT OVERVIEW

The Singer® models 106-2SC-MV and 206-2SC-MV electronic flow control and metering valves are based on the 106-PG or 206-PG main valve.

The pressure in the upper operating chamber is controlled by operating the pilot solenoids. The PLC within the MV1-TP control panel determines whether the opening solenoid or the closing solenoid is operated. The change in valve position is dependent upon which solenoid is operated and the duration of the energized period.

The Singer MV1-TP control panel computes the flow rate based on valve differential pressure and position and operates the pilot solenoids to match the flow rate to the customer's pre-determined (adjustable) set-point. Flow is totalized and displayed via panel readout. In addition, the MV1-TP panel includes a pre-programmed logic controller, touch screen display, labelled wiring and terminal strip.



TYPICAL APPLICATION

Singer® Model MV1 -TP Electronic Flow Control and Metering Panel

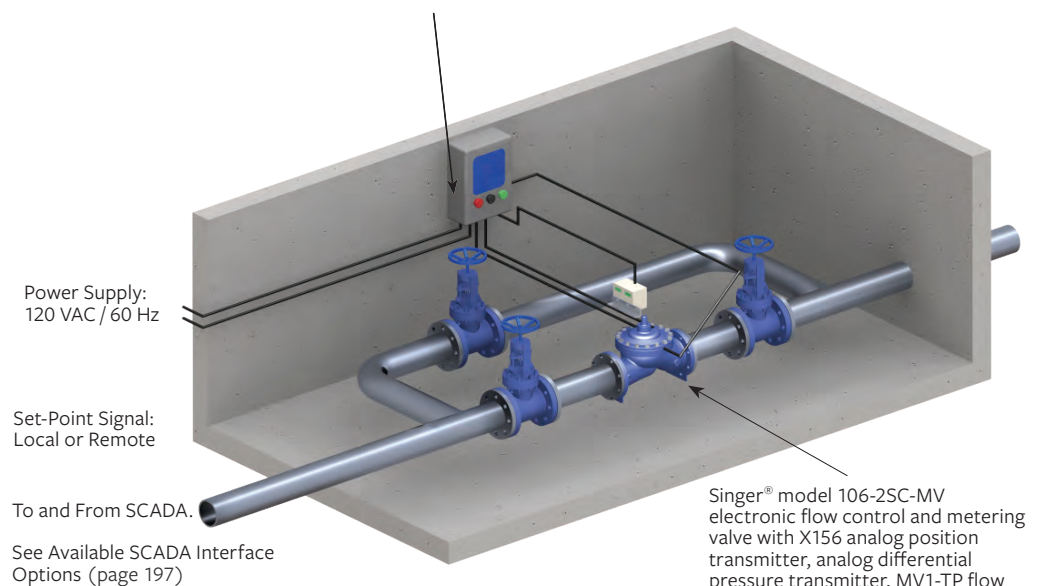

Singer® model 106-2SC-MV electronic flow control and metering valve with X156 analog position transmitter, analog differential pressure transmitter, MV1-TP flow limiting and metering panel, dual solenoid control pilot system.

MODELS 106-2SC-MV / 206 2SC-MV

Electronic Flow Control and Metering Valve

SCHEMATIC DRAWING

NO.	PART
1	Main Valve - 106-PG or 206-PG
2	Isolating Valves - (2A, 2B, 2C, 2D, 2E)
3	Strainer - 40 Mesh Stainless Steel Screen
4	Closing Speed Control
5	Opening Speed Control
6	Closing Solenoid Pilot Valve - 120 VAC / 60 Hz Standard, Other Voltages Available
7	Opening Solenoid Pilot Valve - 120 VAC / 60 Hz Standard, Other Voltages Available
8	Model X156 Analog (4-20 mA) Position Transmitter
9	Differential Pressure Transmitter
10	Manual By-Pass Valves - (10A, 10B) - Normally Closed
11	Model MV1-TP Electronic Flow Control Panel

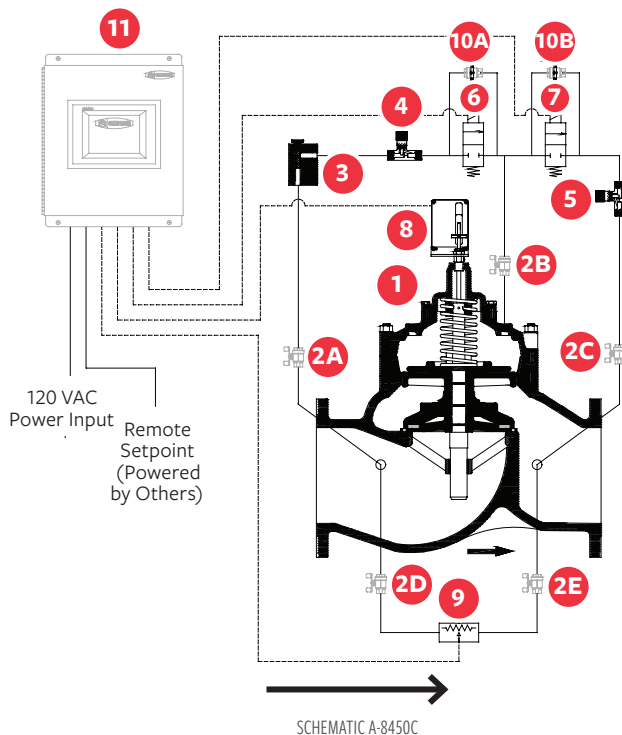

STANDARD MATERIALS

Standard materials for pilot system components are:

- ASTM B-16 brass fittings, copper tubing
- NEMA 4X solenoid coils
- NEMA panel enclosure

SELECTION SUMMARY

1. Select a valve with sufficient capacity, using the allowable operating pressure drop across the valve. Usually line size.
2. Usually operating in the continuous "C", service range up to 20 ft/s / 6 m/s - refer to chart and/or performance curves (see Technical and Sizing Information section, page 231).
3. If the outlet pressure is less than 35% of the inlet pressure, check for cavitation.
4. Ensure the maximum working pressure rating of the valve exceeds the maximum operating pressure.
5. Ensure the solenoid coils are compatible with the electronic controllers - 120 VAC / 60 Hz standard.
6. If the operating pressure differential across the valve will exceed 100 psi / 6.9 bar, consult with us. For applications requiring high pressure drops, refer to Singer model PG-AC (see page 78).

ORDERING INSTRUCTIONS

Refer to page 244 for the order form and ordering instructions.

Additionally, include the following information for this product:

1. Single chamber (106) or (206)
2. Inlet / outlet pressure range
3. Solenoid voltage
4. Optional NEMA 4x control panel enclosure

MODELS 106-2SC-MV / 206 2SC-MV

Electronic Flow Control and Metering Valve

106-2SC-MV

FLOW CAPACITY (SEE 106-PG IN MAIN VALVE SECTION FOR OTHER VALVE DATA)

Size (Inches)	2 1/2"	3"	4"	6"	8"	10"	12"	14"	16"	20"	24"	36"
Size (mm)	65 mm	80 mm	100 mm	150 mm	200 mm	250 mm	300 mm	350 mm	400 mm	500 mm	600 mm	900 mm
Minimum (USGPM) Flat Diaphragm	CF	CF	10	20	40	-	-	-	-	-	-	-
Minimum (USGPM) Rolling Diaphragm	-	-	-	1	1	3	3	3	3	10	10	20
Minimum (L/s) Flat Diaphragm	CF	CF	0.6	1.3	2.5	-	-	-	-	-	-	-
Minimum (L/s) Rolling Diaphragm	-	-	-	0.1	0.1	0.2	0.2	0.2	0.2	0.6	0.6	1.3
Maximum Continuous (USGPM)	CF	CF	800	1800	3100	4900	7000	8500	11000	17500	25000	55475
Maximum Continuous (L/s)	CF	CF	50	114	196	309	442	536	694	1104	1577	3500

206-2SC-MV

FLOW CAPACITY (SEE 206-PG IN MAIN VALVE SECTION FOR OTHER VALVE DATA)

Size (inches)	3"	4"	6"	8"	10"	12"	16"	18"	20"	24 x 16"	24 x 20"	28"	30"	32"	36"	40"	48"
Size (mm)	80 mm	100 mm	150 mm	200 mm	250 mm	300 mm	400 mm	450 mm	500 mm	600 x 400 mm	600 x 500 mm	700 mm	750 mm	800 mm	900 mm	1000 mm	1200 mm
Minimum (USGPM) Flat Diaphragm	CF	5	10	20	40	-	-	-	-	-	-	-	-	-	-	-	-
Minimum (USGPM) Rolling Diaphragm	-	-	-	-	-	3	3	3	3	3	3	10	10	10	10	20	20
Minimum (L/s) Flat Diaphragm	CF	0.3	0.6	1.3	2.5	-	-	-	-	-	-	-	-	-	-	-	-
Minimum (L/s) Rolling Diaphragm	-	-	-	-	-	0.2	0.2	0.2	0.2	0.2	0.2	0.6	0.6	0.6	0.6	1.3	1.3
Maximum Continuous (USGPM)	CF	580	1025	2300	4100	6400	9230	16500	16500	16500	21700	33600	33650	33700	33800	55475	55475
Maximum Continuous (L/s)	CF	37	65	145	260	404	582	1040	1040	1040	1370	2120	2123	2126	2132	3500	3500

Note: CF = Consult with us on all sizes 3" (80 mm) and under

SCP-TP

Single-Process Control Panel

KEY FEATURES

- Compatibility with remote SCADA Modbus, Hardwired 4 to 20 mA or local set-point adjustment
- Simplified single loop process controller with P.I.D. implementation, ON / OFF or 4-20 mA motor control
- Selectable input controls and output alarms
- IP 66, 67 NEMA 4X rated panel
- Colour touch screen interface display
- Equipped with data logging features
- For indoor use only. For outdoor applications, consult factory.

PRODUCT OVERVIEW

The SCP-TP Controller is a simplified process controller designed to complement the Dual Solenoid Control Valve. It offers quick and easy configuration for any single process application as well as on/off applications. The SCP-TP is also equipped to be configured to control the Singer 420 DC Motor. Range of application is dependent on the process variable (feedback) transmitter used, which includes (but not limited to) common automatic control valve functions with conventional pilots. The SCP-TP Controller reads and compares the process feedback (process variable) 4 to 20 mA signal to the desired setting (set-point) 4 to 20 mA signal. The SCP-TP then accurately positions the valve to bring the process variable towards the set-point until they coincide. The SCP-TP is also equipped with data logging features than when enabled can log all sensor feedback and setpoint data with a time stamp.

IDEAL FOR

- Level control
- Pressure control
- Flow control
- Position control
- Data logging
- 420-DC/AC Control

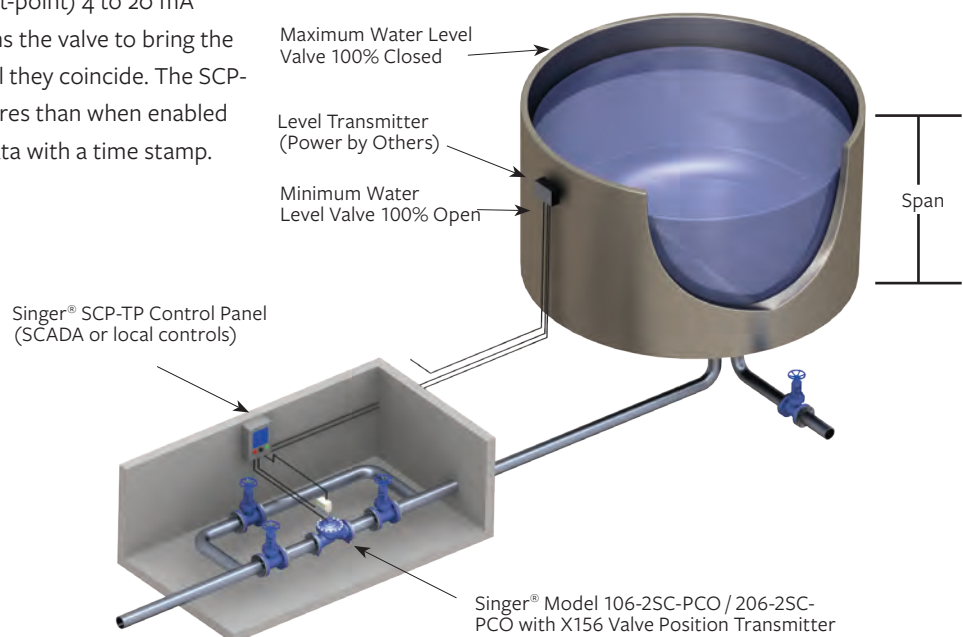

LCP-TP Level Control Panel

KEY FEATURES

- Compatibility with remote SCADA Modbus, Hardwired 4 to 20 mA or local set-point adjustment
- Simplified ON / OFF level controller for 4-20 mA sensor or high / low level switch implementation
- Selectable input controls and output alarms
- IP 66, 67 NEMA 4X rated panel
- Black and white interactive button display screen
- Equipped with data logging features

PRODUCT OVERVIEW

The LCP-TP Level Controller is a single process level controller designed to complement our Single Solenoid Operated/Override Control Valves and 4-20mA level sensor or High / Low Level Switches. This combination package is ideal for filling any kind of tank with water that requires filling to a level setpoint and then drawing down the level of the tank to a secondary setpoint before activating the fill cycle again thus ensuring tank turnover.

The LCP-TP offers quick and easy configuration that allows the LCP-TP Controller to read and compare the level 4 to 20 mA signal to the desired setpoint. The LCP-TP then opens or closes the Singer® control valve to achieve the desired level setpoint. If a High / Low level switch system is preferred the LCP-TP can easily switch configuration to allow for level switch inputs and control the Singer® valve accordingly. Additionally the LCP-TP is also equipped with data logging features than when enabled can log all sensor feedback and setpoint data with a time stamp allowing for system analysis.

IDEAL FOR

- Level control
- Data logging



TYPICAL APPLICATION

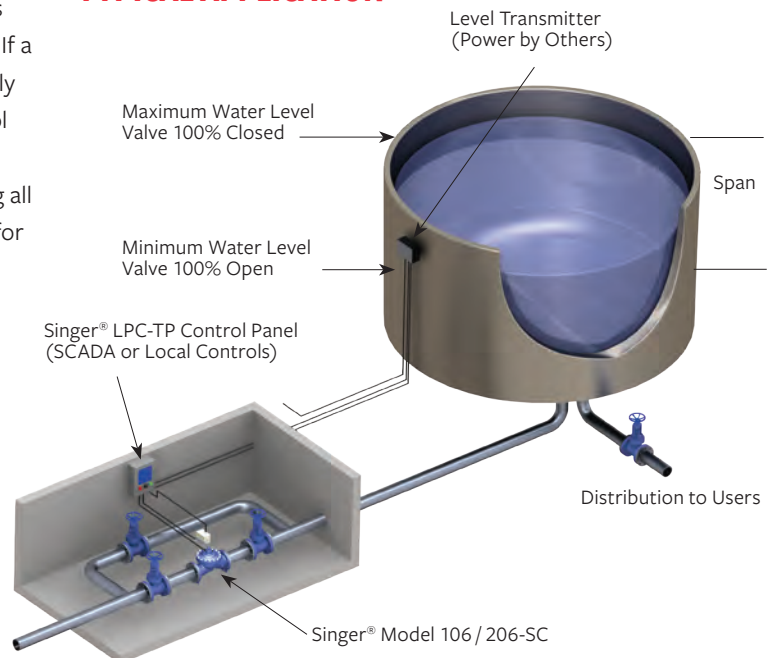

MODEL MCP-TP

Multi Process Control Panel Series

KEY FEATURES

- Compatibility with remote SCADA , Hardwired 4 to 20 mA or local set-point(s) adjustment
- Flexibility of single or multiple process monitoring and control
- Optional 1 panel for multi- valve application
- Precise valve positioning and visual status indication
- Robust and self-contained in NEMA 4X rated panel
- Colour touch screen interface display

For indoor use only. For outdoor applications, consult factory.

PRODUCT OVERVIEW

The MCP-TP Series is a multiple process loop control panel designed to complement the Singer® Model 2SC-PCO Dual Solenoid Control Valve. Range of application is dependent on the feedback (process variables) transmitters used, which is similar to (but not limited to) combination automatic control valve functions with conventional pilots. The MCP-TP control panel has the ability to monitor multiple processes and remotely control the dual solenoid control valve based on system conditions. The MCP-TP control panel can function as a simple single loop controller (eg. pressure reducing, flow control, level control) or as a multiple loop controller (eg. flow and pressure, or reducing and sustaining).

The MCP-TP reads transmitted signals and energizes the dual solenoid pilots on the Singer control valve. The MCP-TP can react to any change in conditions by monitoring the system continuously and comparing actual process values to desired set-point values.

The Multi-Process Control Panel incorporates a high performance PLC-based control with P.I.D. optimization to provide control of multiple processes, such as pressure reducing, flow control, level and sustaining. We will customize the program to match your specific application needs. Optional alarm outputs for SCADA is available.

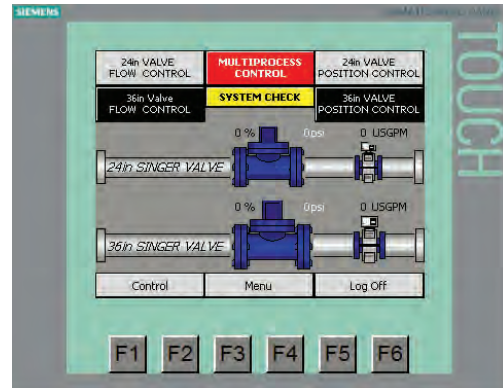

TOUCH PANEL

Model (MCP-TP) touch panel screen is a user-friendly operator interface that enables intuitive control and monitoring. Model (MCP-TP) touch panel screen eliminates the need for mechanical push buttons, switches, and indicator lights and readouts. The screen is custom tailored to customer-specific application requirements.

TOUCH PANEL DETAILS

Dimensions: 7" / 175 mm W x 5" / 125 mm L

Display: 256 Color TFT

Protection: NEMA 4X rain-tight (indoor use only)

Screen can be customized to application

ORDERING INSTRUCTIONS

Refer to page 244 for the order form and ordering instructions.

Additionally, include the following information for this product:

1. Application details
2. Solenoid voltage
3. Source of set-point signal (4-20 mA)
4. Source of process variable signal(s)
5. Number of processes to be controlled

MODEL MCP-TP

Multi Process Control Panel Series

TYPICAL APPLICATION

MCP-TP monitors inlet pressure while filling tank at a relatively steady flow rate. If tank is full, valve closes. If inlet pressure drop below normal, valve will modulate to close to keep inlet pressure from dropping further.

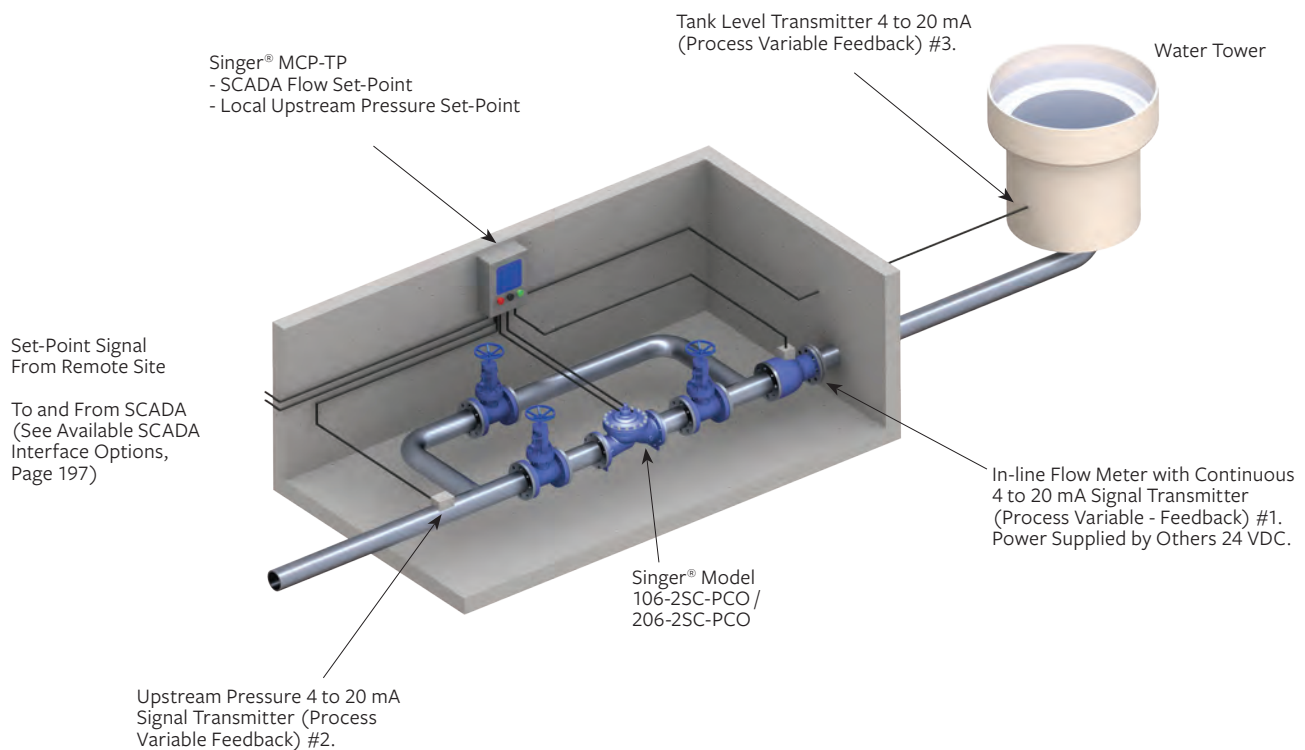

SAP PANEL FOR MODEL RPS-L&H-ET

Surge Anticipator Panel

KEY FEATURES

- Automatically interfaces pressure switch and control valve to protect system from destructive pressure surges
- Visual indication of operational status
- Simple to install
- Minimizes field wiring costs

For indoor use only. For outdoor applications, consult factory.

PRODUCT OVERVIEW

The SAP Surge Anticipator Panel provides the interface between a customer supplied, system pressure switch and the Singer® Surge Anticipating control valve. Together they provide protection against destructive pressure surges.

The SAP panel energizes the control valve pilot solenoid on an abnormally low pressure reading and/or power failure of pumps. The 12 VDC pilot solenoid is energized to open the main valve and relieve the surge pressure from the system. The RPS-L&H-ET (ET - Electronically Timed) valve is equipped with a hydraulic pilot to relieve on abnormally high pressures.

The SAP panel is equipped with adjustable digital delay timers that permit coordination of valve operation with pump start-ups, shutdowns, power failures and down surges.

The SAP panel comes equipped with a long life, high capacity 12 VDC battery, industrial grade battery charger with over current and polarity protection, door mounted volt meter, and battery test feature.

The logical arrangement of indicator lights and the volt meter provide easy supervision of the sequencing and the operating status.

ORDERING INSTRUCTIONS

Refer to page 244 for the order form and ordering instructions.

Additionally, include the following information for this product:

- Optional pressure switch



SAP PANEL FOR MODEL RPS-L&H-ET

Surge Anticipator Panel

TYPICAL APPLICATION

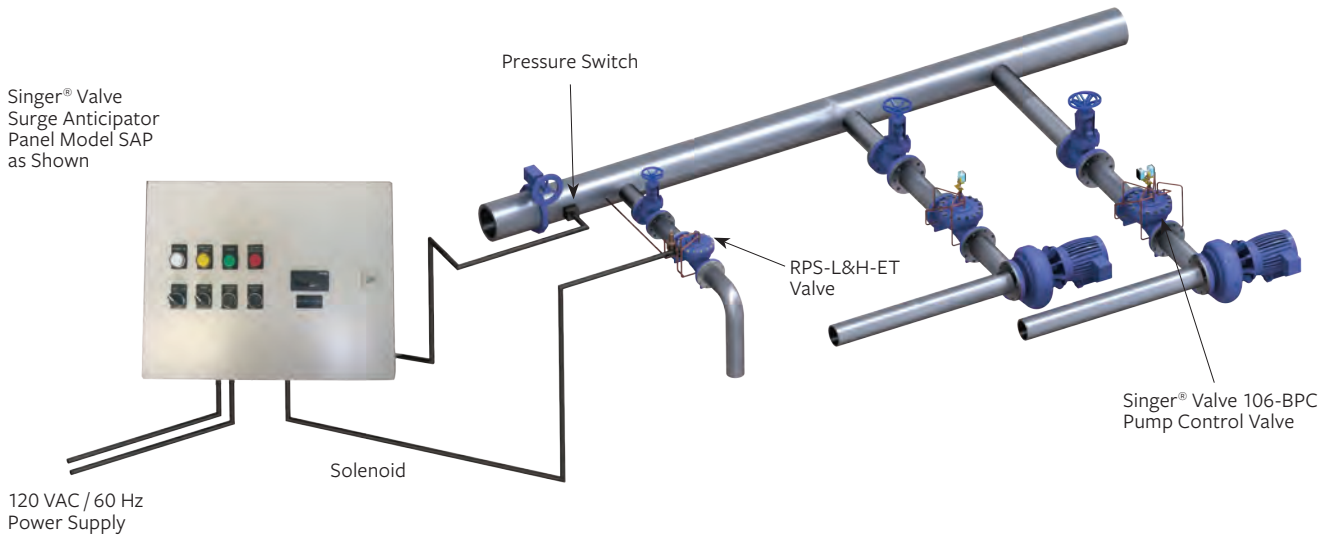

SCHEMATIC DRAWING

NO.	PART
1	Main Valve - 106 / 206-PG
2	Isolating Valve (2A, 2B, 2C)
3	Strainer - 40 mesh, J0097A
4	Fixed Restriction - 3/32" / 2.4 mm
5	Closing Speed Control - 852-B
6	Pressure Switch - Supplied by Others
7	Manual Test Valve - 3-Way ball Valve with Lockable Handle
8	Solenoid Valve - 12 VDC Normally Closed
9	Model 81-RP, Relief Pilot
10	Swing Check Valve - 1/2" / 15 mm
11	Limit Switch Assembly - Optional
12	Connection to Header by Others
14	Pressure Gauge 1/4" / 6 mm NPT

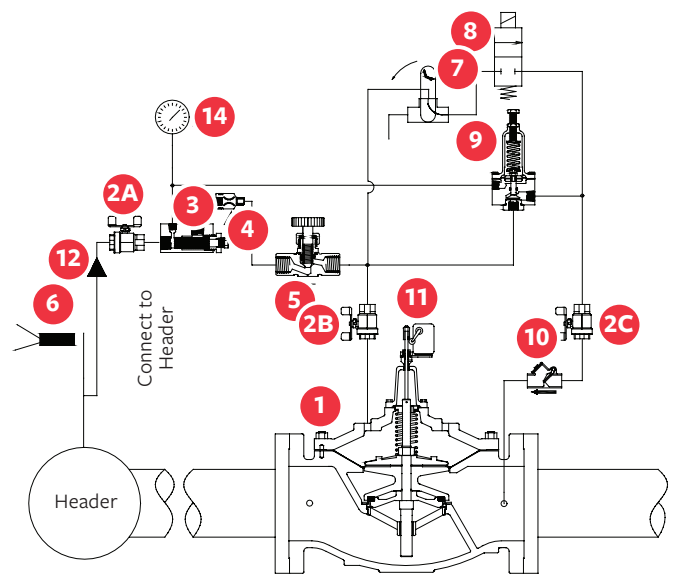

Note:

Singer® Surge Anticipator Control Panel - not shown in schematic but shown in above typical application

SCHEMATIC A-7606C

SPC

Singer® Pump Control Panel

KEY FEATURES

- Simple to install and reduces field wiring costs
- Automatically interfaces pump and control valve to avoid starting and stopping surges
- Suitable for use with either in-line booster or deep well by pass pump control valves
- Control switches for easy system operational execution

For indoor use only. For outdoor applications, consult factory.

PRODUCT OVERVIEW

The SPC Pump Control Panel provides the interface between the pump motor starter and the Singer® pump control valve. The SPC ensures that the pump starts and stops without causing line surges.

The SPC Pump Control Panel energizes the control valve pilot solenoid simultaneously with pump start. When pump shut-down is required the panel keeps the pump running while the pilot solenoid is de-energized. The panel turns the pump off just as the control valve completes its full stroke travel. It is equipped with delay timers and emergency fault contacts to provide the customer with local and remote indication for various operational failure conditions.

The SPC Pump Control Panel is connected to the pilot solenoid and limit switch that are standard components in the control valve pilot system. The panel is also connected to the customer supplied pump discharge pressure switch and the pump motor starter. A second limit switch and emergency shutdown solenoid are optional components for the control valve pilot system.

The logical arrangement of indicator lights with the Hand Off Automatic (HOA) selector switch provides easy supervision of the sequencing and the operating status.

The logical arrangement of Hand / Automatic selector, start, stop and emergency stop switches make the operating simple and easy to execute.



ORDERING INSTRUCTIONS

Refer to page 244 for the order form and ordering instructions.

Additionally, include the following information for this product:

- Solenoid voltage
- SPC-IDC-2LS or SPC-EC-LS configuration

SPC

Singer® Pump Control Panel

TYPICAL APPLICATION

Singer® Pump Control Panel Model
SPC-EC-LS as Shown

Pump Motor Starter

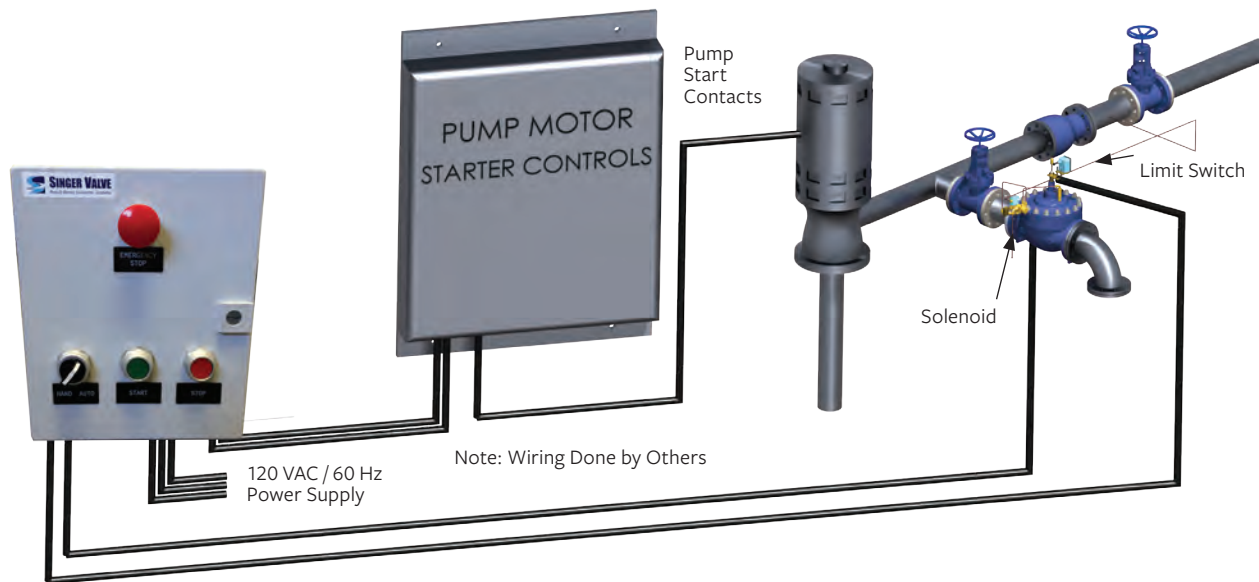

MODEL 420-DC / 420-AC

Automated Pilot Control

KEY FEATURES

- Easily programmable range via USB cable and custom software
- Built in surge suppression and reverse polarity protection
- IP68, 7' / 24 hours (2.134 m/24 hours)
- High-torque motors increase actuator's operational life
- Downstream pressure follows the control signal within +/- 1 psi / 0.068 bar
- 4 -20 mA setpoint input and 4 - 20 mA position feedback

PRODUCT OVERVIEW

The 420 DC/AC provides a reliable, simple and cost efficient way to automate today's water systems. A sturdy slow speed 24 VDC motor actuator drive can be installed on a variety of Singer® pilots. The motor actuator responds to a 4-20 mA signal, rotating the pilot adjusting screw corresponding to the change in signal. The number of turns is adjustable and may be programmed to suit the pressure changes required for the application. The 420-DC or 420-AC requires less than 2 amps of power to operate, controlled by the 4-20 mA signals from the water distribution SCADA system. The very low power requirement lends itself well to a solar powered self-contained station. Extended power failure would result in relatively steady pressure at the last setting. Optional freeze or default to high or low pressure is available on loss of signal.

IDEAL FOR

- Pressure Management Systems – utilizing pressure reducing pilot to give adjustable pressure settings based on system demand.
- Remote or difficult to reach control valves where adjustments need to be made, and using SCADA is the best option.



ORDERING INSTRUCTIONS

Refer to page 246 for the order form and ordering instructions.

Additionally, include the following information for this product:

1. Application (Singer® Model #)
2. Pilot utilized
3. Pilot spring range
4. Required adjustable operating pressure range

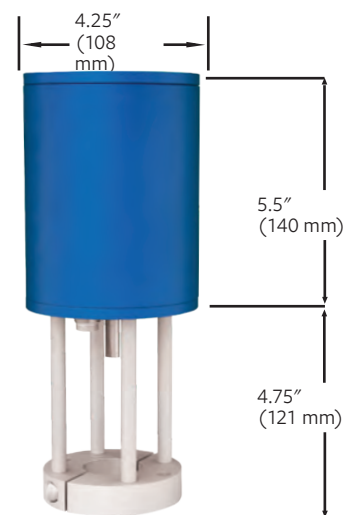

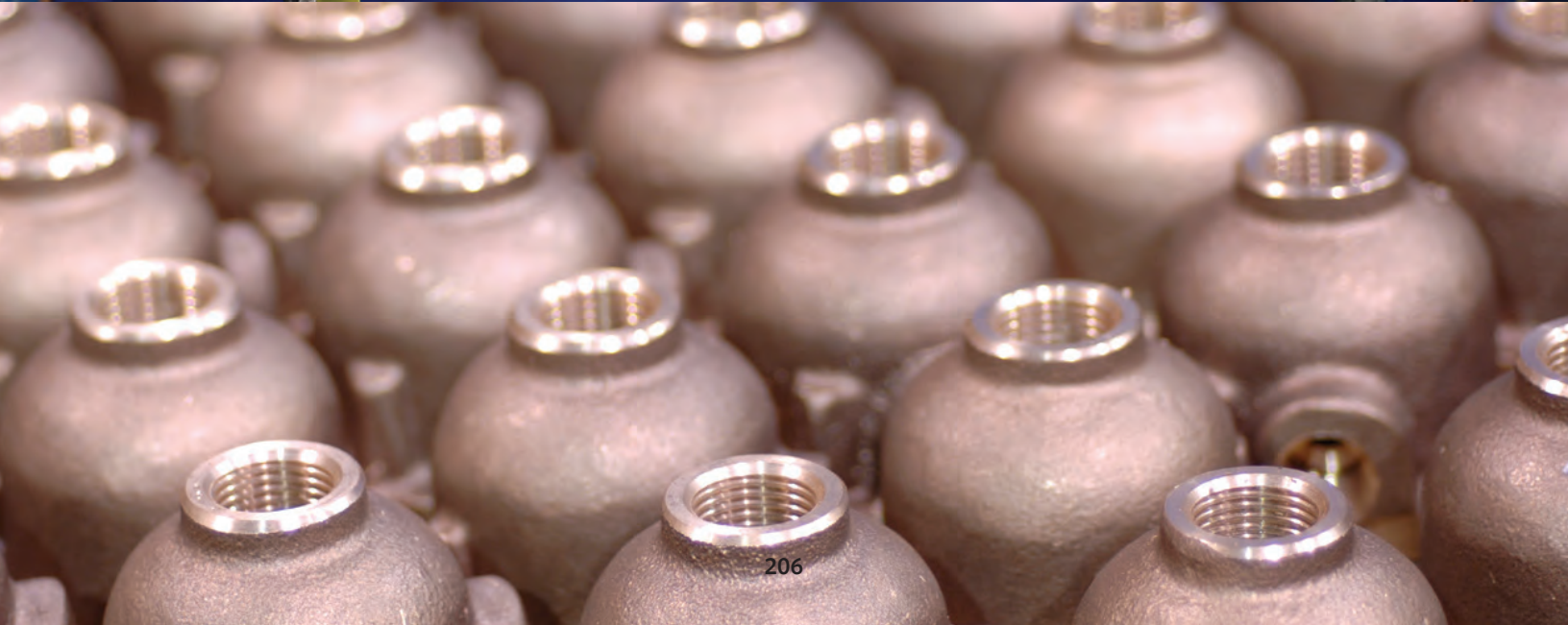
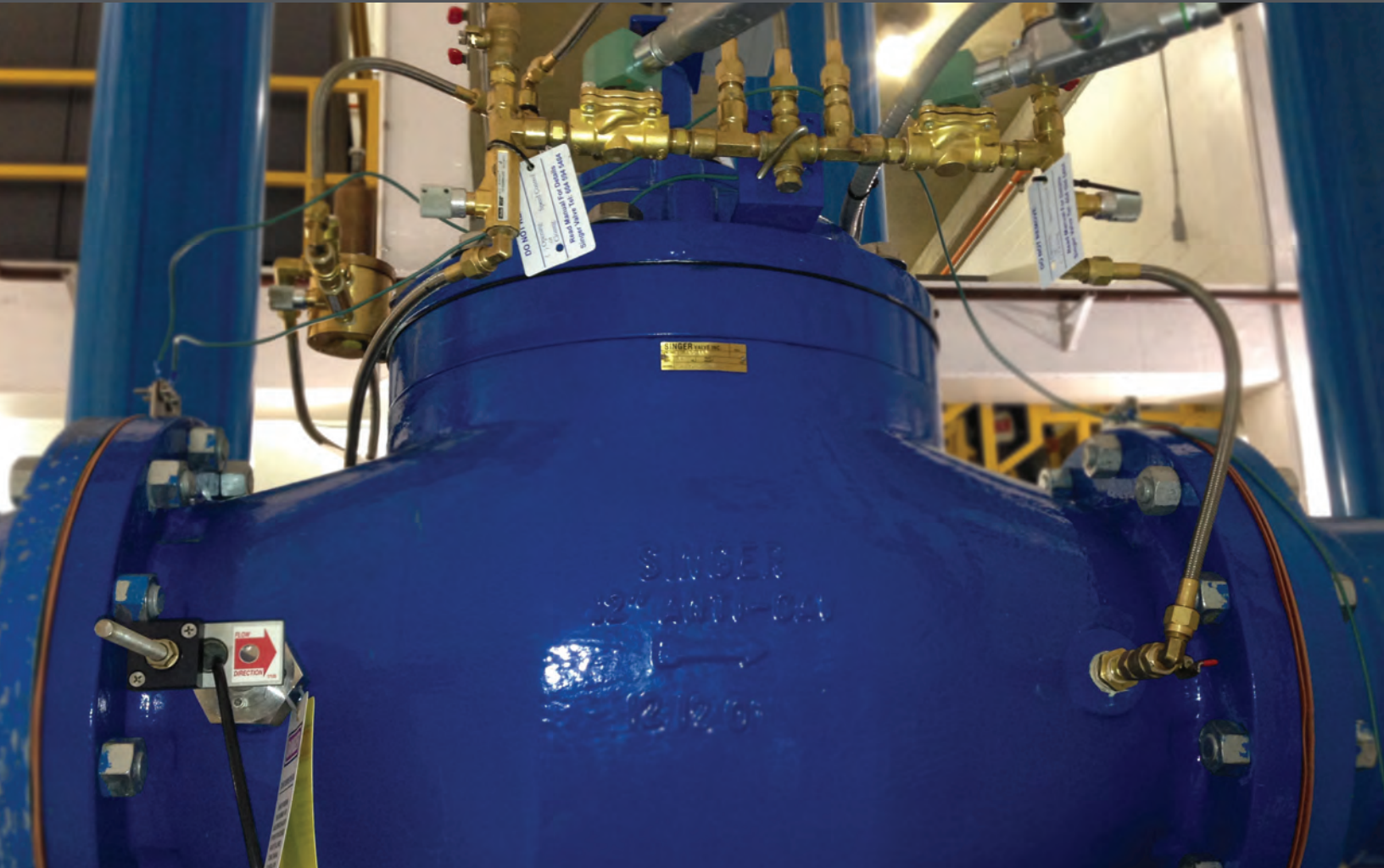

PILOTS AND ACCESSORIES

Customize. Accessorize. Specialize.

Our pilots and accessories offer you options and choices. Like customizing a Singer® float valve with our rotary float pilot or adding a Singer internal drop check assembly to a main valve for quick, positive shut-off when normal forward flow stops. To resist corrosion, you can upgrade components to stainless steel or to prevent mineral build-up and premature valve failure, you can choose our flexible stainless steel braided hose. Pilots. Needles. Tubing. Strainers. Options we design. Accessories you specify.

Oxy-Nitride Stem – Main Valve Option

Prevents build-up. Resists corrosion. Reduces maintenance.

Our proprietary oxy-nitride treated 316 stainless steel stem is ideal when mineral build-up on stems may cause maintenance problems or operational malfunctions. The stem is treated in an aerated salt bath so it reduces or prevents mineral build-up, allowing the stem to stroke freely as it passes through the guide bushing.

Ideal for:

- Reclaimed water applications

Pressure Reducing Pilot PR-160

Self-cleaning. Self-flushing. Non-clogging.

This normally open pilot is spring and diaphragm operated. It has a non-clogging pilot guide stem above the diaphragm, which is removed from the flow of water in the main pilot chamber. Because the outlet is located in the bottom of the pilot, 90 degrees to the inlet, the pilot is self-cleaning and self-flushing, thereby eliminating debris build-up. It also minimizes turbulence and false readings. This is the standard pressure reducing pilot for all our pressure reducing valves.

Ideal for:

- Regulating water pressure

MODEL 160

Pressure Reducing Pilot (Normally Open)

PRODUCT OVERVIEW

The 160 Pressure Reducing Pilot is a spring and diaphragm operated, normally open pilot. The inner valve is held open by the spring and when the control pressure below the diaphragm exceeds the force of the spring, the pilot valve closes.

Model 160 is the standard pressure reducing pilot on all 106 and 206 series valves.

ORDERING INSTRUCTIONS

Refer to page 244 for the order form and ordering instructions.

SCHEMATIC DRAWING

NO.	PART
1	Adjusting Screw (Stainless Steel)
2	Locknut (Stainless Steel)
3	Spring Step (Stainless Steel)
4	Spring (Steel)
5	Spring Casing Stem (Bronze)
6	Stem (Stainless Steel)
7	Guide Bushing (Delrin)
8	Retaining Ring (Stainless Steel)
9	Clamp Plate Seal (Brass)
10	Diaphragm (EPDM)
12	Yoke (Stainless Steel)
13	Seat Ring Seal (Buna-N)
14	Seat Ring (Stainless Steel)
15	Inner Valve (Stainless Steel and EPDM)
16	Body (Bronze)
17	Outlet Connector (Brass)

Available in all Stainless Steel construction.
Viton or Buna-N Elastomers



PRESSURE REDUCING PILOT

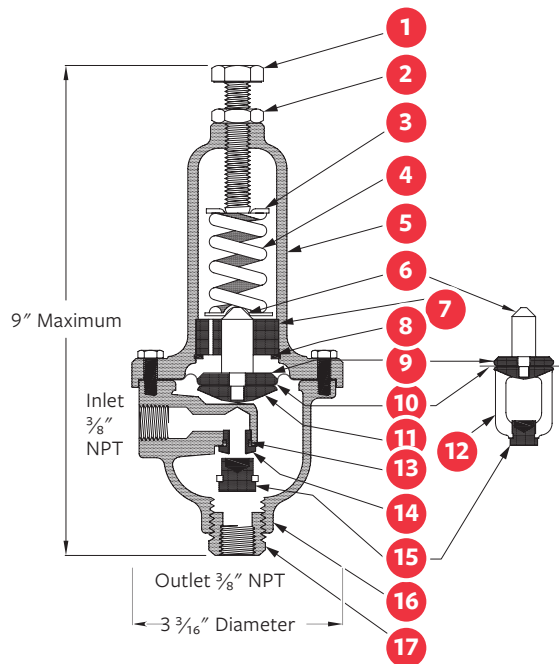

	SPRING RANGES	APPROXIMATE PSI PER TURN
Standard	20 to 200 psi (1.38 to 13.8 bar)	30 psi (2 bar) per turn
	5 to 50 psi (0.345 to 3.45 bar)	9 psi (0.62 bar) per turn
Optional	10 to 80 psi (0.7 to 5.5 bar)	14 psi (0.96 bar) per turn
	100 to 300 psi (6.9 to 20.7 bar)	42 psi (2.9 bar) per turn

MODEL 160 RF

Rate of Flow Pilot (Normally Open)

PRODUCT OVERVIEW

The 160-RF pilot is a spring and diaphragm operated pilot designed to sense a differential across an external orifice plate. It is a normally open pilot that also has a sensing port in the spring casing, above the diaphragm and is available in stainless steel.

The inner valve is held open by the spring and when the control pressure below the diaphragm exceeds the combined forces of the spring and the sensing pressure, the pilot valve closes. The 160-RF is the standard rate of flow control pilot on all 106 and 206 series valves.



ORDERING INSTRUCTIONS

Refer to page 244 for the order form and ordering instructions.

SCHEMATIC DRAWING

NO.	PART
1	Body (Bronze)
*2	Diaphragm (EPDM)
4	Stem (Stainless Steel)
*5	Inner Valve (Stainless Steel & EPDM)
6	Yoke (Stainless Steel)
7	Clamp Plate (Brass)
8	Spring Casing (Bronze)
9	Retaining Ring (Stainless Steel)
10	Guide Bushing (DELRIN)
11, 16, 17	Fasteners (Stainless Steel)
*12, 19	Seal (Buna-N)
13, 21	Spring (Spring Steel)
14, 20	Spring Step (Stainless Steel)
15	Thread Seal (Steel & Buna-N)
18	Seat Ring (Stainless Steel)
**21	Bucking Spring (Stainless Steel)
**22	Bleed Screw (Stainless Steel)
**23	Bleed Screw Seal (Stainless Steel and Neoprene)

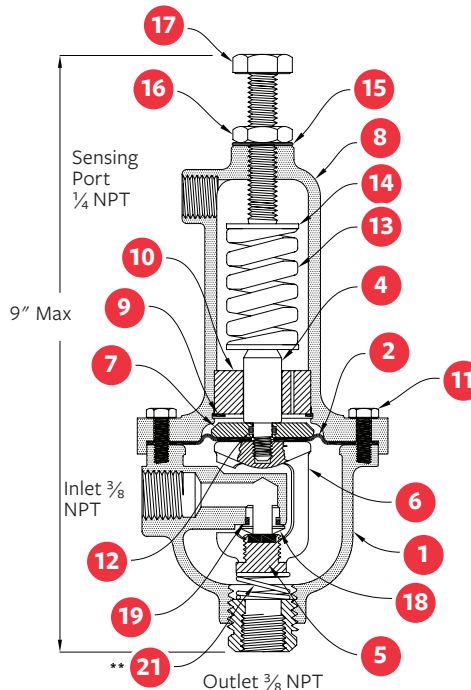

*Recommended Spare Parts - supplied in Parts KIT
 **Range 2- 20 psid only

	SPRING RANGES	APPROXIMATE PSI PER TURN
Standard	2 to 20 psi (0.14 to 1.4 bar)	2 psi (0.14 bar) per turn
Optional	25 to 50 psi (1.73 to 3.45 bar)	3.4 psi (0.23 bar) per turn

MODEL 81-RP

Pressure Relief Pilot (Normally Closed)

PRODUCT OVERVIEW

The 81-RP is a remote sensing, high capacity, spring and diaphragm operated, normally closed pilot. The inner valve is held closed by the spring. When the sensed pressure increases above the spring setting, the pilot opens.

Model 81-RP pilot is used as the standard pressure relief/sustaining pilot on all 106 and 206 series valves.

ORDERING INSTRUCTIONS

Refer to page 244 for the order form and ordering instructions.

SCHEMATIC DRAWING

NO.	PART
1	Adjusting Screw (Stainless Steel)
2	Lock Nut (Stainless Steel)
3	Spring Casing (Bronze)
4	Upper Spring Step (Stainless Steel)
5	Spring (Steel)
6	Lower Spring Step (Stainless Steel)
7	Stem Locknut (Stainless Steel)
8	Clamp Plate Seal (Buna-N)
9	Clamp Plate (Brass)
10	Diaphragm (EPDM)
11	Body Seal (Buna-N)
12	Inner Valve (Stainless Steel and EPDM)
13	Body (Brass)
14	Seat Ring Seal (Buna-N)
15	Seat (Stainless Steel)

Options: All Stainless Steel construction.
Viton or Buna-N Elastomers

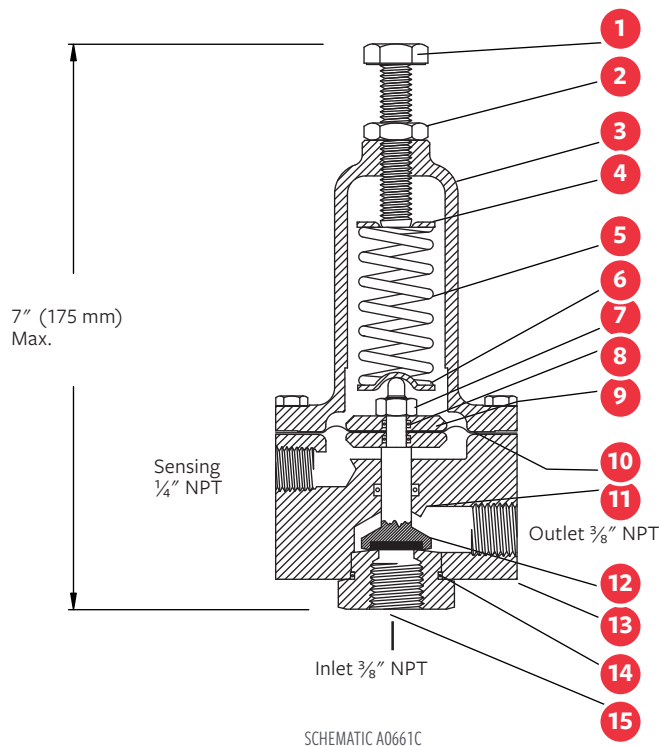

	SPRING RANGES	APPROXIMATE PSI PER TURN
Standard	20 to 200 psi (1.38 to 13.8 bar)	25 psi (1.7 bar) per turn
	5 to 50 psi (0.345 to 3.45 bar)	9 psi (0.62 bar) per turn
Optional	10 to 80 psi (0.7 to 5.5 bar)	14 psi (0.96 bar) per turn
	100 to 300 psi (6.9 to 20.7 bar)	42 psi (2.9 bar) per turn

MODEL 83-RP

High Pressure Relief Pilot (Normally Closed)

PRODUCT OVERVIEW

The 83-RP is a spring and diaphragm operated, normally closed pilot specifically designed for high pressure applications. The inner valve is held closed by the spring. When the control sensed pressure below the diaphragm exceeds the force of the spring, the pilot valve opens.

Model 83-RP pilot is used as the standard pressure relief pilot where the operating pressures are excessive, such as a 300 psi / 20.7 bar level.

ORDERING INSTRUCTIONS

Refer to page 244 for the order form and ordering instructions.

SCHEMATIC DRAWING

NO.	PART
1	Adjusting Screw (Stainless Steel)
2	Spring Casing (Brass)
3	Spring Steps (3A, 3B) (Stainless Steel)
4	Spring (Steel)
5	Diaphragm (EPDM)
6	Clamp Plates (Brass)
7	Inner Valve (Stainless Steel and EPDM)
8	Body (Brass)
9	Seat (Stainless Steel)
10	O-Ring Seals (Buna-N)

Options: Available in all Stainless Steel construction

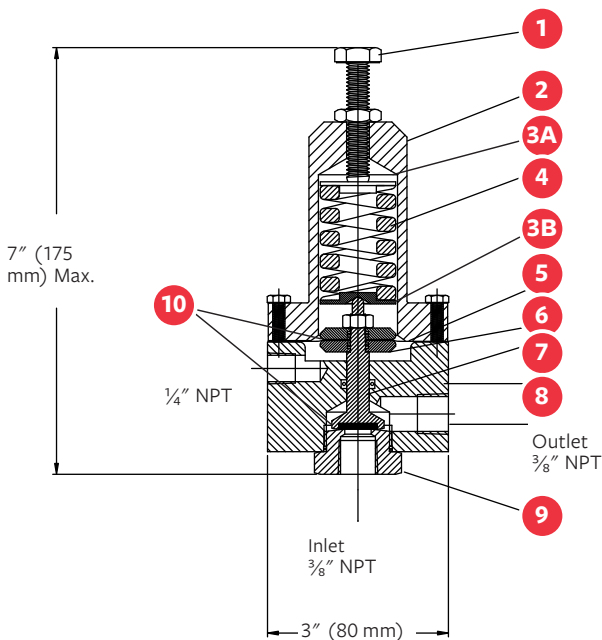

SCHEMATIC A0781A

	SPRING RANGES	APPROXIMATE PSI PER TURN
Standard	200 to 500 psi (13.8 to 34.5 bar)	80 psi (5.5 bar) per turn

MODEL 81-RPD

Differential Pressure Relief Pilot (Normally Closed)

PRODUCT OVERVIEW

The 81-RPD is a remote sensing, high capacity, spring and diaphragm operated, normally closed, differential pilot. The inner valve is held closed by the spring. When the pressure under the diaphragm overcomes the combined forces of the spring setting and the pressure above the diaphragm, the pilot opens. The 81-RPD valve is used for remote sensing of a differential pressure for normally closed applications.

ORDERING INSTRUCTIONS

Refer to page 244 for the order form and ordering instructions.

SCHEMATIC DRAWING

NO.	PART
1	Adjusting Screw (Stainless Steel)
2	Lock Nut (Stainless Steel)
3	Thread Seal (Steel and Buna-N)
4	Spring Casing (Brass)
5	Spring Step (Stainless Steel)
6	Spring (Stainless Steel)
7	Stem Lock Nut (Stainless Steel)
8	Spring Casing Capscrew (Stainless Steel)
9	Diaphragm (EPDM)
10	Clamp Plate (Brass)
11	Clamp Plate Seal (Buna-N)
12	Stem Seal (Buna-N)
13	Inner Valve (Stainless Steel and EPDM)
14	Seat Ring Seal (Buna-N)
15	Body (Brass)
16	Seal (Stainless Steel)

Options: Available in all Stainless Steel construction.

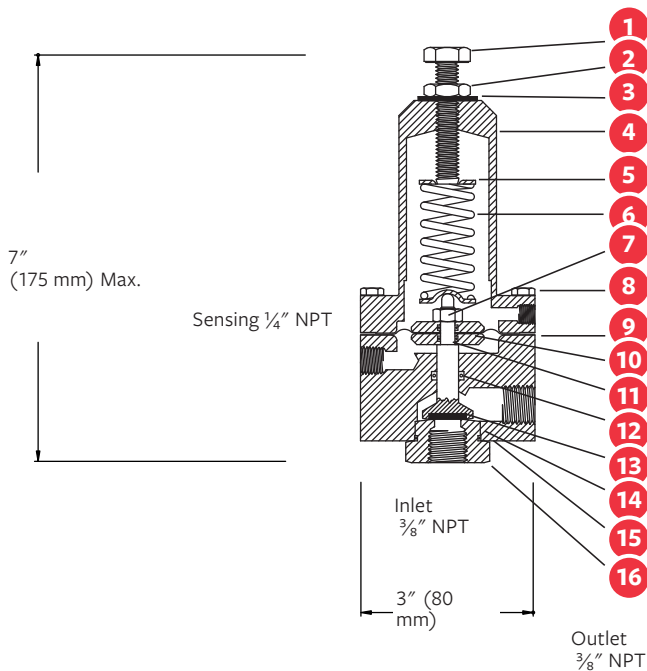

SCHEMATIC A0662D

	SPRING RANGES	APPROXIMATE PSI PER TURN
Standard	20 to 200 psi (1.38 to 13.8 bar)	30 psi (2 bar) per turn
	5 to 25 psi (0.345 to 1.72 bar)	3 psi (0.2 bar) per turn
Optional	10 to 80 psi (0.7 to 5.5 bar)	10 psi (0.7 bar) per turn
	100 to 350 psi (6.9 to 24 bar)	41 psi (2.82 bar) per turn

MODEL 301-4

Altitude Pilot Valve

PRODUCT OVERVIEW

An altitude pilot valve is spring and diaphragm operated; it controls the water level in a reservoir by sensing the hydrostatic head. When the hydrostatic head equals the spring force, the pilot connects port “X” (connection to main valve inlet) to port “K” (connection to main valve bonnet). The main valve closes. When the hydrostatic pressure decreases slightly, the port “X to K” connection is closed by the inner valve. When the hydrostatic pressure is reduced even further, the pilot connects port “K” (main valve bonnet) to “EX” (exhaust to atmosphere). Then the main valve opens.

Model 301-4 pilot is used as the standard pilot on all 106 and 206 series altitude valves.

ORDERING INSTRUCTIONS

Refer to page 244 for the order form and ordering instructions.

SCHEMATIC DRAWING

NO.	PART
1	Stem (Stainless Steel)
2	Spring (Steel)
3	Diaphragm Casing (Ductile Iron)
4	Diaphragm (Buna-N)
5	Inner Valve (Stainless Steel and EPDM)
6	Body (Stainless Steel)

Standard Materials:

Other standard material of the pilot construction include brass, aluminum, stainless steel, Buna-N

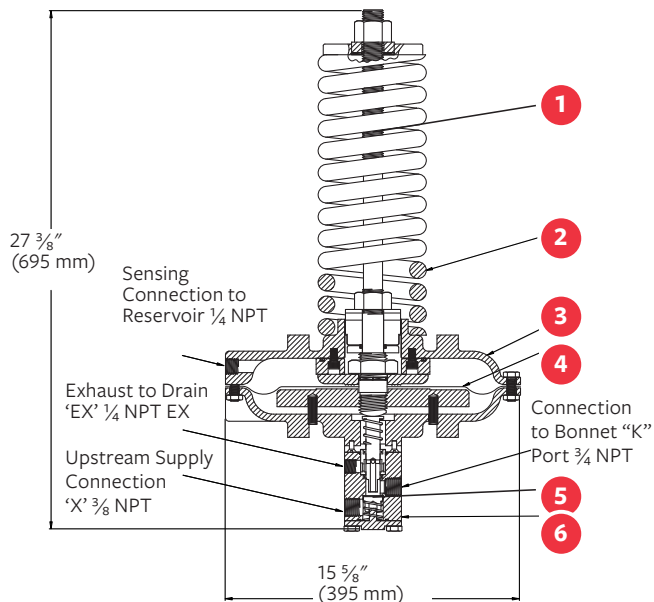

SCHEMATIC A0847A

APPROXIMATE FIXED DIFFERENTIAL

MODEL	SPRING RANGE / ELEVATION	DELAYED OPENING	APPROXIMATE FEET PER TURN
301-4	4 to 20' (1 to 6 m)	1' (0.3 m)	1' (0.3 m) per turn
301-4	10 to 60' (3 to 18 m)	1' (0.3 m)	2' (0.6 m) per turn
301-4	40 to 125' (12 to 38 m)	2' (0.6 m)	3' (0.9 m) per turn
301-5	60 to 225' (18 to 69 m)	3' (0.9 m)	6' (1.8 m) per turn

MODEL R-400

Modulating Float Pilot

PRODUCT OVERVIEW

The R-400 is a modulating float pilot with a plastic float, suitable for remote installation on a tank or reservoir. It positions the main valve in proportion to the reservoir level. Standard configuration is for the pilot to close on rising level.

Specify “Reverse Acting” for the pilot to open on rising level. The polypropylene float connects to the pilot on a 10” / 250 mm brass rod.

The R-400 pilot is used as the standard float pilot on all 106 and 206 series modulating float valves.

ORDERING INSTRUCTIONS

Refer to page 244 for the order form and ordering instructions.

SCHEMATIC DRAWING

NO.	PART
1	Body (Bronze)
2	Inner Valve (Buna-N)
3	3/8" NPT Outlet
4	Stem (Brass)
5	Lever (Brass)
6	Serrated Arm (Brass)
7	Float Rod (Brass)
8	Lock Nut (Stainless Steel)
9	Float (Polypropylene)

Options: Copper float; Stainless Steel Rod.

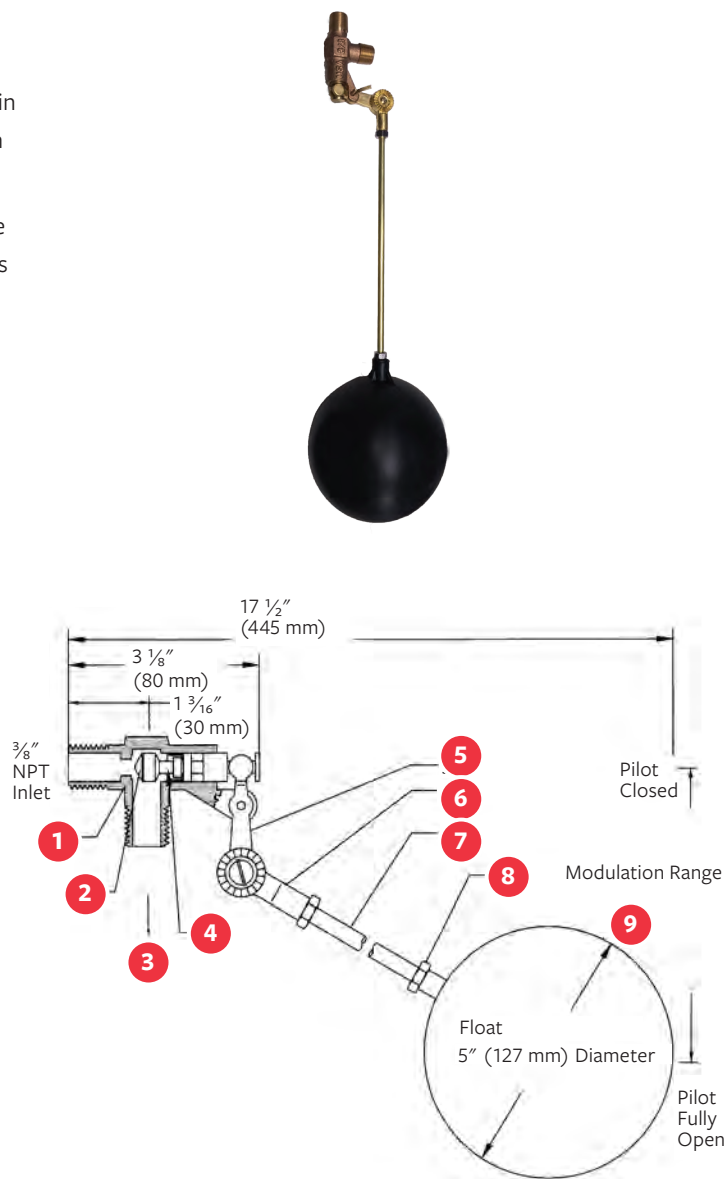

SCHEMATIC A0714D

MODEL 34

Modulating Float Pilot with Vertical Rod

PRODUCT OVERVIEW

The 34 modulating float pilot is comprised of a copper float and brass rod assembly which moves vertically. As the level rises, the float lifts and the valve closes. The 34 pilot is optional pilot, available for modulating applications where the float and rod are installed in a still well and/or vertical action is preferred.

ORDERING INSTRUCTIONS

Refer to page 244 for the order form and ordering instructions.

SCHEMATIC DRAWING

NO.	PART
1	Body (Bronze)
2	Inner Valve (Stainless Steel)
3	Valve Stem (Stainless Steel)
4	Connector Bar (Brass)
5	Mounting Bracket (SST303)
6	Counter Weight (Cast Iron)
7	Guide Bar (Brass)
8	Float Rod (Brass)
9	Lever Arm (Brass)

Options: Available with stainless steel float and rod

Note: When ordered as a part and/or when shipping via air freight, the 1/4" / 6.35 mm diameter x 4' / 1.2 m round brass rod is not included.

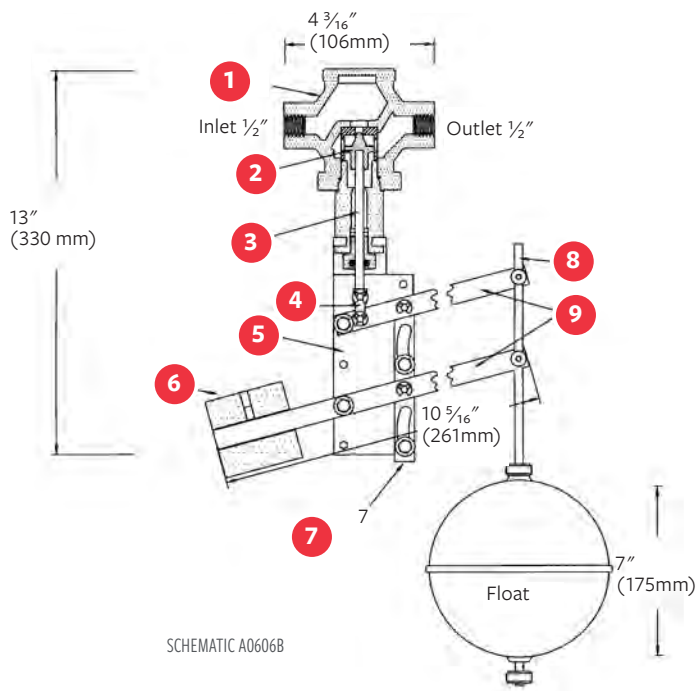

MODEL 35

Modulating Float Pilot

PRODUCT OVERVIEW

Model 35 is a Stainless Steel modulating float pilot with a Stainless Steel float, suitable for remote installation on a tank or reservoir.

It positions the main valve in proportion to the Reservoir level. Standard configuration is for the pilot to close on rising level.

Specify reverse acting for the pilot to open on rising level. Reverse acting Inlet pressure on pilot is a minimum of 60 psi with main valve inlet pressure maximum of 10 psi. Consult Singer® staff for installations outside these parameters.

The Stainless Steel float connects to the pilot using a 10" / 250 mm Stainless Steel rod.



ORDERING INSTRUCTIONS

Refer to page 244 for the order form and ordering instructions.

SCHEMATIC DRAWING

NO.	PART
1	Body (Stainless Steel AISI 303)
2	Cam (Stainless Steel AISI 303)
3	Inner valve (Stainless Steel AISI 303)
4	Locknut (2) (Stainless Steel 18-8)
5	Stop pin (Stainless Steel AISI 302)
6	Pivot pin (Stainless Steel AISI 302)
7	Float rod (Stainless Steel AISI 303)
8	(Stainless Steel 18-8)

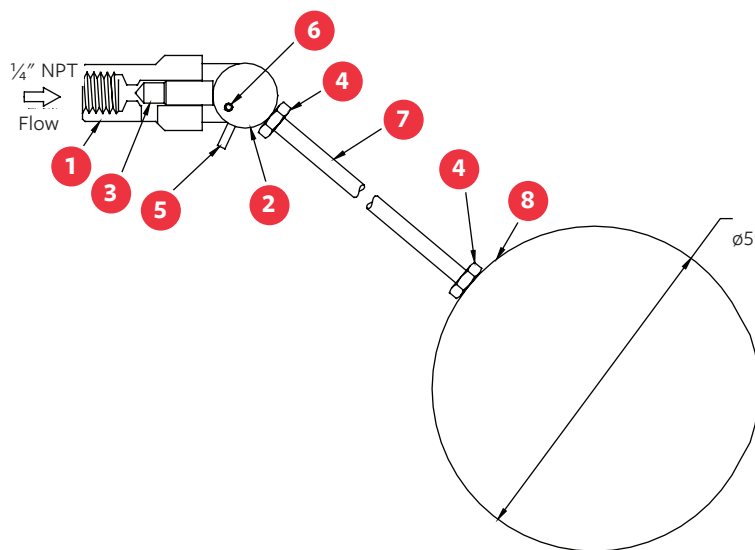

SCHEMATIC A0797B

MODEL 39

Non-Modulating Float Pilot with Vertical Rod

PRODUCT OVERVIEW

The 39 non-modulating float pilot is designed to operate an On-Off float valve. The differential between the level where the valve opens and the level where the valve closes, is adjustable. The standard configuration is for the pilot valve to close on high level and open at a low level.

The 39 pilot is used as the standard pilot on all non-modulating F-Type 5, 106 and 206 series float valves.

ORDERING INSTRUCTIONS

Refer to page 244 for the order form and ordering instructions.

SCHEMATIC DRAWING

NO.	PART
1	Body (Brass)
2	Inner Valve O-Rings (Buna-N)
3	Inner Valve (Brass)
4	Connector Bar
5	Mounting Bracket (Brass)
6	Guide Bar (Brass)
7	Counter Weight (Cast Iron - Epoxy Coating)
8	Float Rod (Brass)
9	Lever Arm (Brass)
10	Adjustable Stop (Brass)
11	Float (Copper)
12	Adjustable Stop Opening (Brass)

Options: Available in Stainless Steel construction.

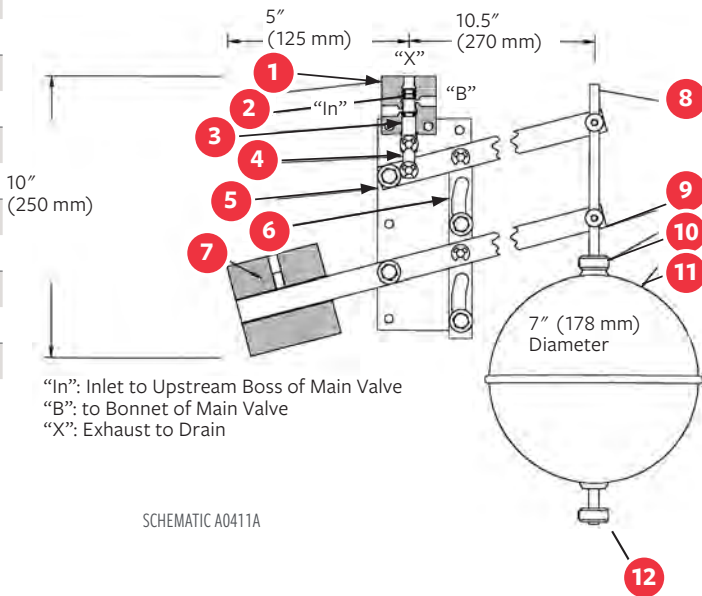

MODEL 43

Rotary Float Pilot (On / Off)

PRODUCT OVERVIEW

The 43 stainless steel float actuated pilot with non-modulating rotary motion, provides non-modulating On-Off operation of the main valve. It has higher capacity and faster response time than other non-modulating float pilots. The differential between the level where the main valve opens and the level where the main valve closes, is adjustable. The 43 pilot allows for faster operation of the main valve over traditional float pilots, due to increased port size. The standard configuration is for the pilot to close the main valve on high level and open the main valve on low level. The 43 pilot is used on all non-modulating model F-Type 5, 106 and 206 series float valves.

The 43 pilot has a pressure rating of 80 psi / 5.5 bar.

ORDERING INSTRUCTIONS

Refer to page 244 for the order form and ordering instructions.



NO.	PART
1	Mounting Bracket (Brass)
2	Counter Weight (Stainless Steel)
3	Float Rod (SST)
4	Float (SST)

Standard Materials: SST pilot, inner valve, SST float, 4' / 1.2 m SST rod.

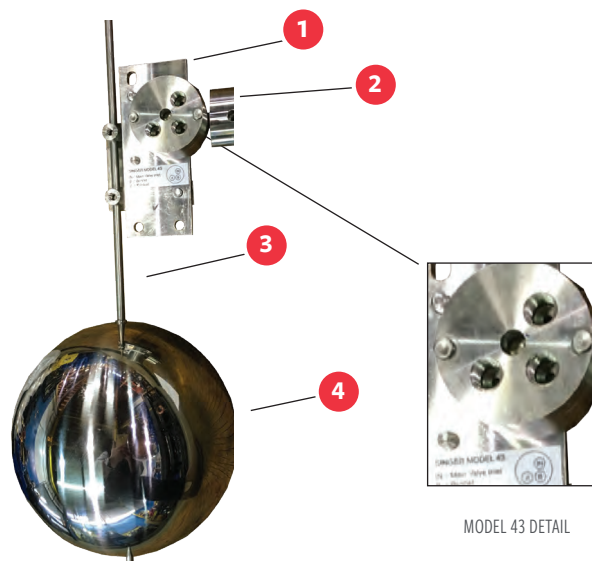

MODEL 43 DETAIL

MODEL 43

Rotary Float Pilot (On / Off)

SCHEMATIC DRAWING

NO.	PART
1	Mounting Bracket (Stainless Steel)
2	Main Lever Arm (Stainless Steel)
3	Counterweight (Stainless Steel)
4	Counterweight Rod (Stainless Steel)
5	Lower Lever Arm (Stainless Steel)
6	Space Bar (Stainless Steel)
7	Float Rod (Stainless Steel)
8	Adjustable Stop (Stainless Steel)
9	Inner Valve (Teflon)
10	Casing (Stainless Steel)
11	Stem (Stainless Steel)
12	Wave Spring Washer (Stainless Steel)
13	Body (Stainless Steel)
14	Lock Nut (Stainless Steel)

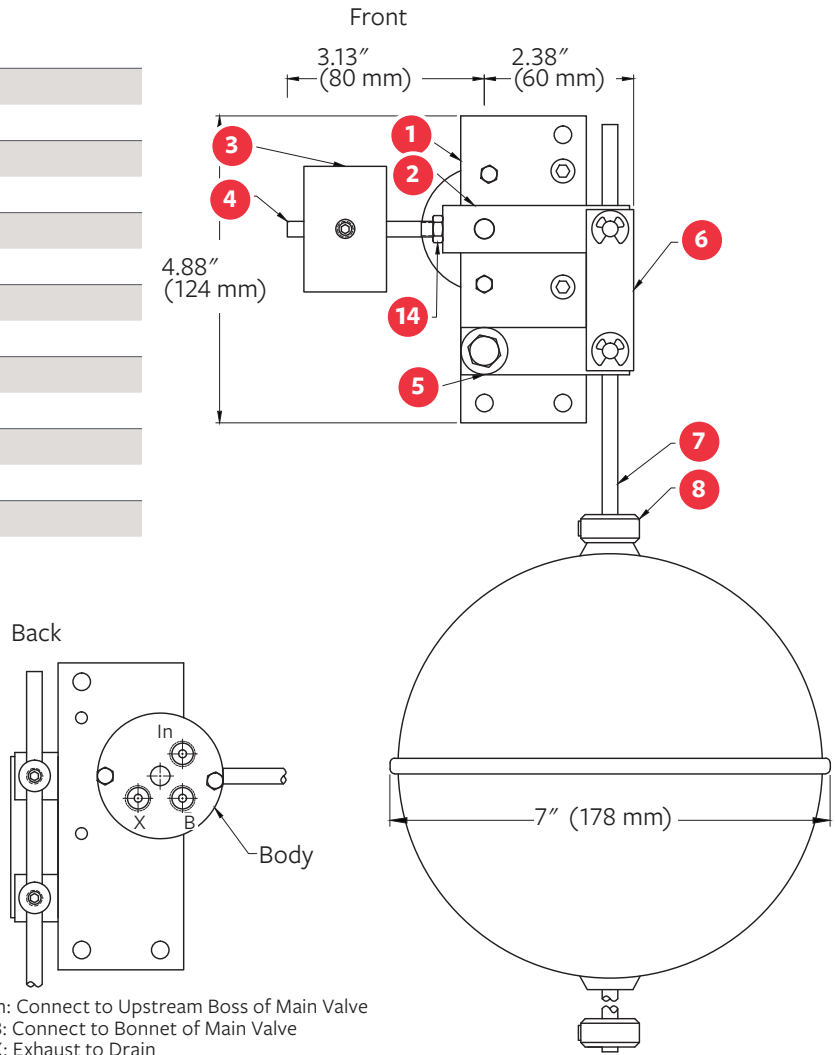

In: Connect to Upstream Boss of Main Valve
 B: Connect to Bonnet of Main Valve
 X: Exhaust to Drain

SCHEMATIC A0986A

MODEL 106-RD

Differential Relief Pilot (Normally Closed)

PRODUCT OVERVIEW

The model 106-RD is a spring and diaphragm operated, normally closed pilot designed to allow flow when the inlet pressure exceeds the outlet pressure by a predetermined amount. The model 106-RD is used as a differential control valve on Singer® model 106-A-Type 4 altitude control valves.

ORDERING INSTRUCTIONS

Refer to page 244 for the order form and ordering instructions.

SCHEMATIC DRAWING

NO.	PART
1	Adjusting Screw (Stainless Steel)
2	Locknut (Stainless Steel)
3	Thread Seal (Stainless Steel & Buna-N)
4	Spring Step (Brass)
5	Spring (Stainless Steel)
6	Spring Casing (Brass)
7	Spring Casing Screws (Stainless Steel)
8	Spring Cup (Brass)
9	Diaphragm (EPDM)
10	Body (Brass)

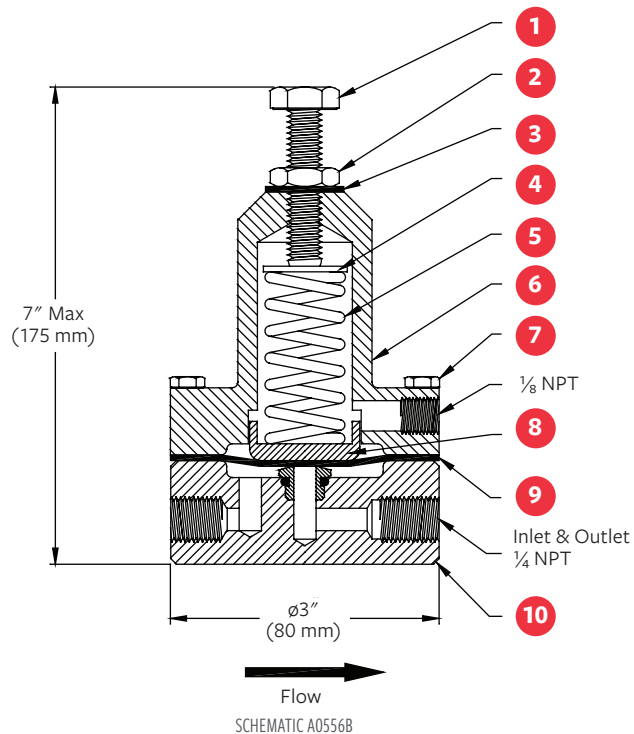
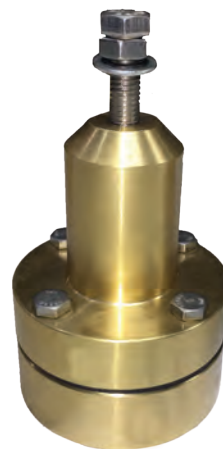

MODEL 630-RPD

Differential Pilot (Normally Closed)

PRODUCT OVERVIEW

The model 630-RPD is a remote sensing, spring and diaphragm operated, normally closed pilot with large diaphragm area for increased sensitivity.

The pilot opens when the control pressure exceeds the spring force or the differential established by the spring.

The model 630 is used for special applications where a low pressure set point or highly sensitive and responsive pilot is required.



ORDERING INSTRUCTIONS

Refer to page 244 for the order form and ordering instructions.

SCHEMATIC DRAWING

NO.	PART
1	Diaphragm Model 630 Pilot
2	Spring Casing Model 625
3	Upper Clamp Plate Model 630
4	Clamp Plate Pilot O-Ring Brass
5	Inner Valve - 81RP(D) & 83RP EPDM-WRAS Finished SST 316

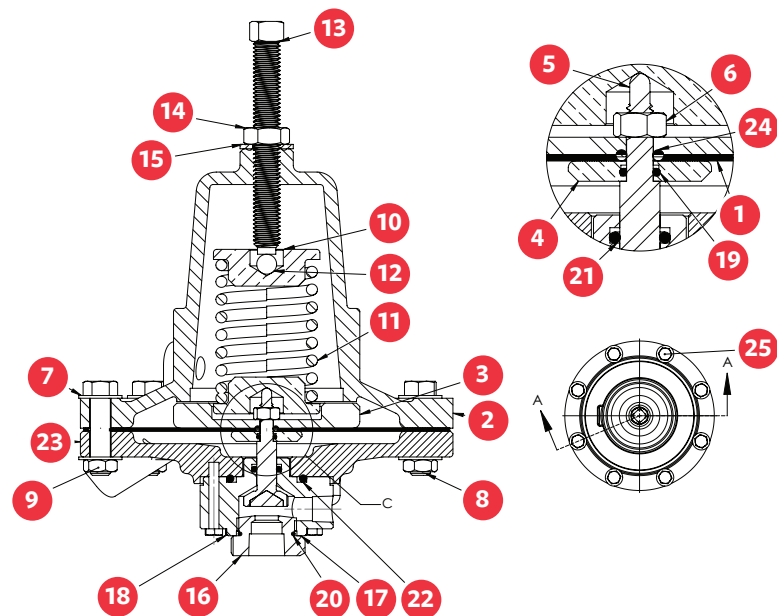

NO.	PART
6	Nut 1/4-20 SS 304
7	Washer 3/8" SAE SST
8	3/8-16UNC X 1 1/2 HX HD CAP SS
9	Jam Nut 3/8-16 SS 304
10	Spring Step Model 630
11	Spring ID 1.5 FL 4 WD 0.207
12	Ball Bearing 625 Adjusting Screw
13	Set Screw 1/2-13UNC X 4 SQR HD
14	Jam Nut 1/2-13 SST 304 18-8
15	Thread Seal 1/2
16	Seat Ring RPD & Model 81RP SST 316
17	Pilot Body Model 630
18	Screw HEX HD 10-32 X 2 SST 304 18-8
19	O-Ring 2-010 N1470-70
20	O-Ring 2-021 N1470-70
21	O-Ring 2-110 N0299-50
22	O-Ring 2-218 N1470-70
23	Diaphragm Flange Model 630
24	O-Ring 2-108 N0674-70
25	HBOLT 3/8-16x2.06 - MACH 304

Standard Materials:

Other standard material of the pilot construction include stainless steel, Buna-N, and brass

X - RPD High Pressure Sensing Connection - 1/4"NPT

Y - RPD Low Pressure Sensing Connection - 1/4"NPT

MODEL 82-PR

Pilot (Normally Open)

PRODUCT OVERVIEW

The model 82-PR is a spring and diaphragm operated, normally open pilot valve, with the sensing chamber(s) separated from the operating chambers. It closes when the control pressure below the diaphragm exceeds the force of the spring. The model 82-PR is used as the standard low pressure pilot on model RPS-L&H anticipating surge valves.

ORDERING INSTRUCTIONS

Refer to page 244 for the order form and ordering instructions.

SCHEMATIC DRAWING

NO.	PART
1	Adjusting Screw (Stainless Steel)
2	Locknut (Stainless Steel)
3	Spring Step (Stainless Steel)
4	Spring Casing (Brass)
5	Spring (Stainless Steel)
6	Stem Locknut (Stainless Steel)
7	Diaphragm (EPDM)
8	Body (Brass)
9	Bottom Cap (Brass)
10	Disc Retainer (Stainless)
11	Resilient Disc (Buna-N)
12	Inner Valve (Stainless Steel)
13	Spring Casing Screws (Stainless Steel)
14	Clamp Plate (Brass)
15	O-Ring Seals (Buna-N)

Standard Materials:

Other standard material of the pilot construction include stainless steel, Buna-N, and brass

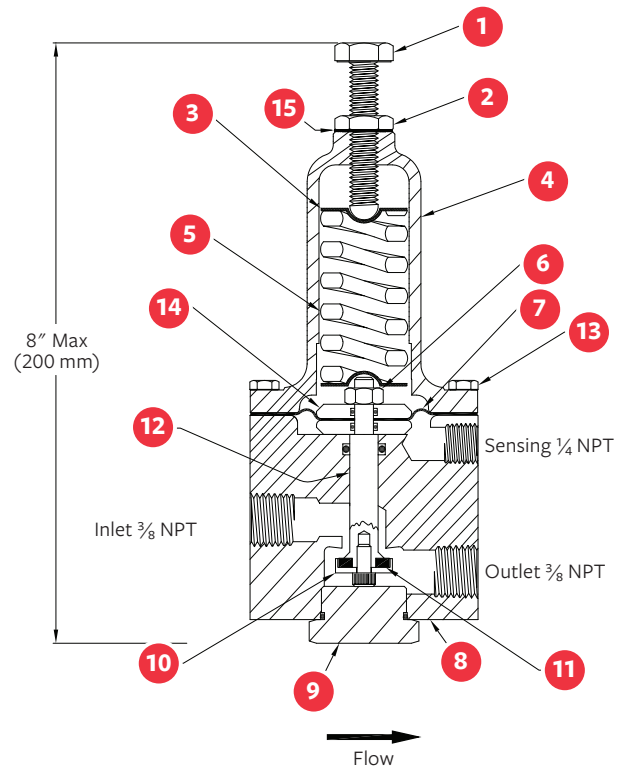

SCHEMATIC A0667C

MODEL 167

Proportional Pilot

PRODUCT OVERVIEW

The 167 Proportional Pilot is a direct acting, diaphragm operated pressure reducing valve. The valve is held open by the lower diaphragm, opposes the force of the upper diaphragm to close the valve.

SPECIFICATIONS

- Pilot is available in four models: 16%, 30%, 42% and 60% (outlet pressure vs inlet pressure)
- Max pressure: 400 psi (27.6 bar)
- Max temperature: 180° F (82° C)

ORDERING INSTRUCTIONS

Refer to page 244 for the order form and ordering instructions.
Schematic Drawing

SCHEMATIC DRAWING

NO.	PART
1	Body Pilot 167 Stainless Steel
2	Seat 167 Stainless Steel Pilot
3	EPDM O-Ring
4	Screw HEX HD 10-32 X 5/8 SST 18-8
5	Poppet 167 Stainless Steel
6	Cap 167 Brass
7	Yoke Pilot 167 316 Stainless Steel
8	Seat Inner Valve Pilot EPDM / 167 Stainless Steel
9	Stem 167 Stainless Steel
10	Clamp Plate 167 PR Brass
11	Adaptor 167
12	Guide Bushing 167
13	Snap Ring
14	EPDM Diaphragm Upper

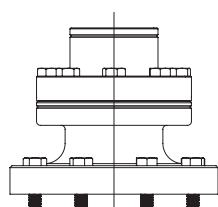
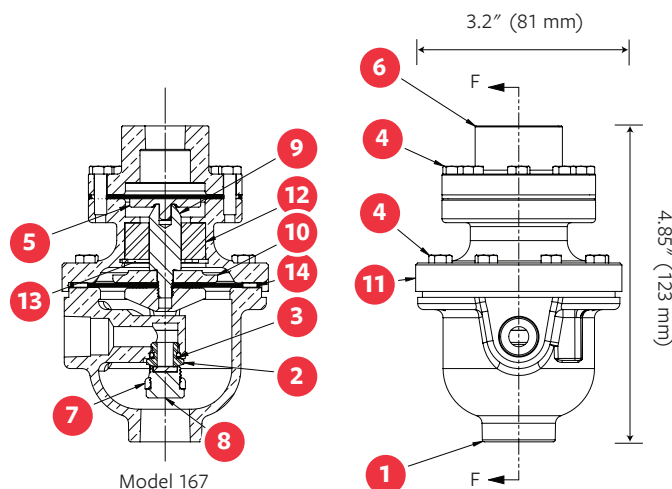

16% ONE GROOVES

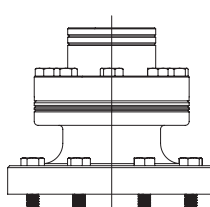

30% TWO GROOVES

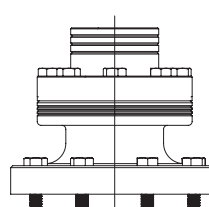

42% THREE GROOVES

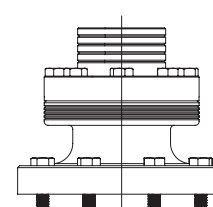

60% FOUR GROOVES

MODEL J0223A

Building Trades Reducing Pilot

PRODUCT OVERVIEW

- Compact design, corrosion resistant construction
- Brass body with brass bonnet
- Miniature brass 1/8", 1/4" PTF
- Brass bonnet equipped with pressure adjusting screw
- Indoor applications only
- For use on 3" pressure reducing valves & smaller

ORDERING INSTRUCTIONS

Refer to page 244 for the order form and ordering instructions.

SCHEMATIC DRAWING

NO.	PART
1	Adjusting Screw (Steel)
2	Nut, Lock (Brass)
3	Springrest (Steel)
4	Bonnet (Brass)
5	Spring (Steel)
6	Slip Ring (Polyethylene)
7	Diaphragm ASSY (Buna-N, Brass, Stainless)
8	Seat-Valve (Acetal)
9	Gasket-Seat (Nitrile)
10	Valve ASSY (Brass, Buna-N)
11	Spring-Valve (Stainless)
12	Body, 1/4 PTF (Brass)
13	Pipe Plug (Brass) *Not shown

Specifications

Fluid: Water
 Maximum pressure: 400 psig (27 bar)
 Gauge Ports: 1/8" PTF
 Operating temperature: Water service 35° to 175° F (2° to 80° C) Typical flow for water service at 100 psig (7 bar) inlet pressure, 60 psig (4 bar) set pressure and a drop of 15 psig (1 bar) from set 1.3 gpm (4.9 lpm)

Materials

Body: Brass
 Bonnet: Brass
 Valve: Brass / Nitrile
 Valve seat: Acetal Resin
 Elastomers: Nitrile
 Warranty 2 years
 Range: 0-125 psig (0-8 bar)

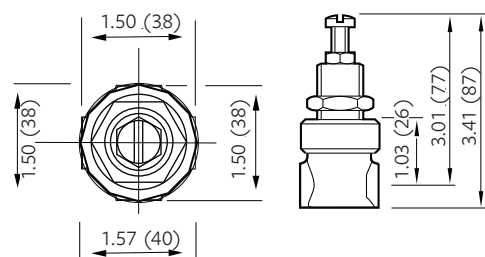
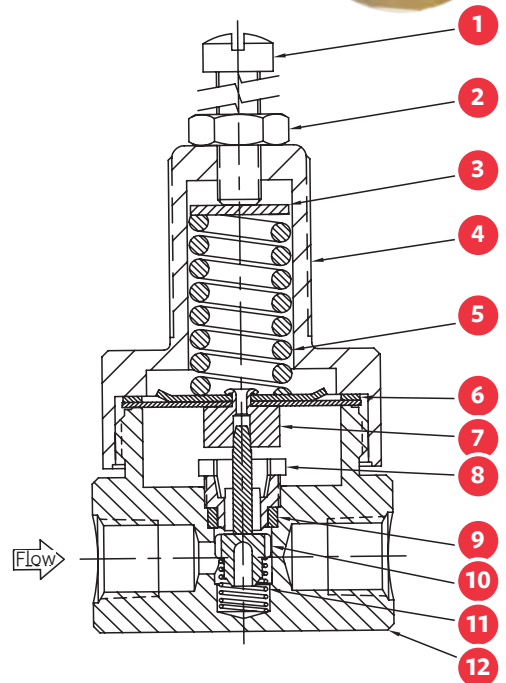
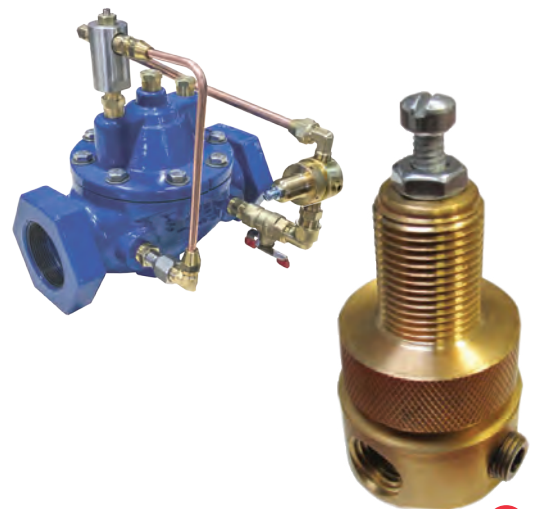

STAINLESS STEEL HOSE

Stainless Steel Braided Hose



COPPER

- Standard material for tubing
- Corrosion resistant
- Reliable and long-term performance



STAINLESS STEEL

- Optional upgrade
- Significantly stronger and more durable
- Corrosion and oxidation resistant



STAINLESS STEEL BRAIDED HOSE

- Optional upgrade
- Completely flexible
- Significantly stronger and more durable
- Corrosion and oxidation resistant

		SIZE	WORKING PRESSURE	LENGTHS	CONNECTION TYPE
Copper	Standard	1/4" / 6 mm 3/8" / 9.5 mm 1/2" / 12.7 mm 3/4" / 19 mm	1/4": 1,406 psi / 96.9 bar 3/8": 984 psi / 67.8 bar 1/2": 727 psi / 50.1 bar 3/4": 511 psi / 35.2 bar	Any	SAE
Stainless Steel	Optional Upgrade	1/4" / 6 mm 3/8" / 9.5 mm 1/2" / 12.7 mm 3/4" / 19 mm	1/4": 21,000 psi / 1,447.3 bar 3/8": 14,000 psi / 965.5 bar 1/2": 10,500 psi / 724.1 bar 3/4": 7,000 psi / 482.8 bar	Any	Compression
Braided Hose	Optional Upgrade	1/4" / 6 mm 3/8" / 9.5 mm 1/2" / 12.7 mm 3/4" / 19 mm	1/4": 3,000 psi / 206.8 bar 3/8": 2,500 psi / 172.4 bar 1/2": 2,000 psi / 137.9 bar 3/4": 1,500 psi / 103.4 bar	Any	SAE / JIC

ORDERING INSTRUCTIONS

Refer to page 244 for the order form and ordering instructions.

Additionally, include the following information for this product:

- Material(s)

MODEL 26

Operating Speed Control

PRODUCT OVERVIEW

The 26 Opening Speed Control is a self-cleaning, opening speed control. It is used in conjunction with a fixed restriction orifice that is usually threaded into port 3. The 26 stabilizer allows free flow down to the bonnet (port 1) and restricts flow up from port 1.

The 26 Opening Speed Control is used as the standard flow stabilizer (opening speed control) on model 106-PR or 206-PR pressure reducing valves or any other model that requires low flow stabilization.

PRODUCT LINE DRAWING

NO.	PART
1	Adjusting Screw
2	Locknut
3	Screw Seal
4	Body
5	Inner Valve
6	Spring
7	Spring Retainer

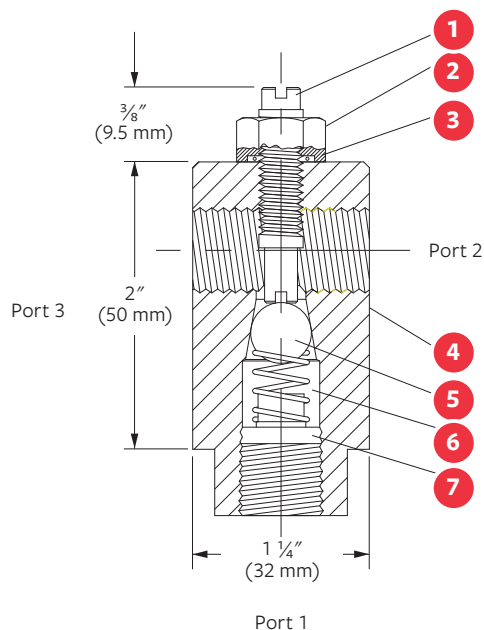

STANDARD MATERIALS

- Body: AISI 303 SST
- Spring Retainer: ASTM B16 Brass
- Locknut: ASTM B16 Brass
- Adjusting Screw: AISI 303 SST
- Inner Valve: AISI 303 SST
- Spring: AISI 303 SST
- Screw Seal: Buna-N

ORDERING INSTRUCTIONS

- Refer to page 244 for the order form and ordering instructions.

FIXED RESTRICTION

PRODUCT OVERVIEW

The fixed restriction is a 303 stainless steel bodied fitting with a stainless steel orifice plug. The fixed restriction controls the flow rate in the pilot system.

The orifices are sized to provide the proper control to a select series of valve sizes only. This all-stainless steel version replaces all previous versions of the brass body, with stainless steel insert.

SIZES

- 'A' 1/8" / 3.2 mm orifice
- 'B' 1/16" / 1.6 mm orifice
- 'C' 3/32" / 2.4 mm orifice
- 'D' 1/4" / 6.35 mm orifice
- 'E' 7/64" / 2.8 mm orifice

ORDERING INSTRUCTIONS

Refer to page 244 for the order form and ordering instructions.

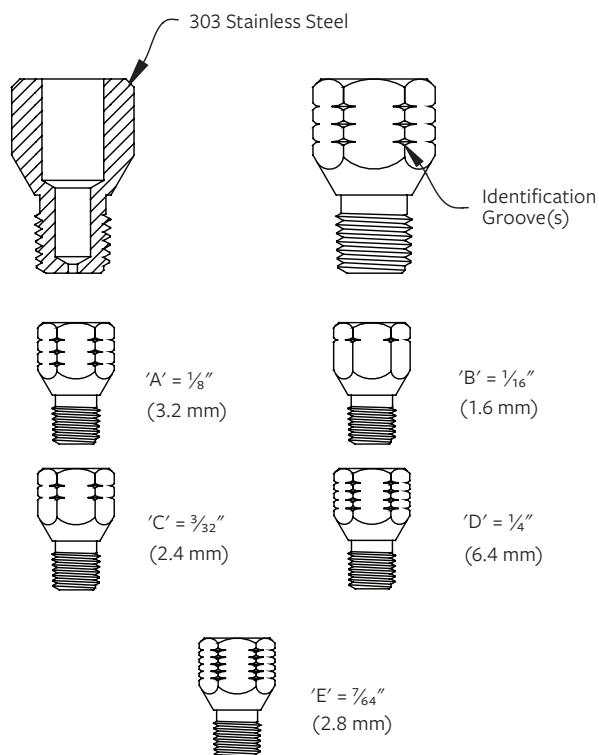

SPEED CONTROL / NEEDLE VALVES

Flow Control Valves / Pilot Check Valves

MODEL 852-B NEEDLE VALVE

The 852-B needle valve is a pilot speed control valve. The body is brass and the stem is stainless steel with a fine thread for controlling flow. O ring packing assures leak proof, trouble free service. 1/4" / 6.35 mm NPT female to female end connections.

SPECIFICATIONS

- Maximum operating temperature: 180° F / 82° C
- Maximum working pressure: 400 psi / 27.6 bar



MODEL MICROMETER NEEDLE VALVES

Micrometer needle valves allow for precise speed control. There is virtually infinite flow adjustment in both directions. Standard end connections are female-to-female 1/4" / 6.35 mm NPT.

STANDARD MATERIALS

- Forged brass body
- Buna-N seals
- Stainless steel stem

SPECIFICATIONS

- Maximum fluid temperature: 180° F / 82° C
- Maximum pressure rating: 2000 psi / 138 bar



MODEL MICROMETER FLOW CONTROL VALVES

Micrometer flow control valves allow for precise flow control. There is full flow in one direction and adjustable restricted flow in the opposite direction. They are standard on certain models, such as BPC pump control valves and available as an option for other applications. Standard end connections are female-to-female 1/4" / 6.35 mm NPT.

STANDARD MATERIALS

- Forged brass body
- Stainless steel stem
- Buna-N seals
- Urethane disc
- Stainless Retaining Ring

SPECIFICATIONS

- Maximum fluid temperature: 140° F / 60° C
- Maximum pressure rating: 2000 psi / 138 bar



MODEL 10 & 12 PILOT CHECK VALVES

The 10 pilot check valve is standard on all 106 and 206 series valves requiring a pilot check function such as BPC, PR-C, RPS-C types. It is designed to require a low "cracking" differential pressure to open. The 12 has a higher "cracking" pressure and requires more differential pressure to open.

STANDARD MATERIALS

- Body: ASTM B16 brass
- Inner Valve: Lexan
- Seat Ring: ASTM B-16 brass
- Seals: Buna-N

SPECIFICATIONS

- Maximum working temperature: 180° F / 82° C
- Maximum working pressure: 400 psi / 27.6 bar



MODELS J0098B & J0097B

Strainers

PRODUCT OVERVIEW

There are two versions of the standard AISI 316 stainless steel strainer with 40 mesh stainless steel screens. The standard strainer J0098B has a $\frac{3}{8}$ " / 9.5 mm blowdown/maintenance port for access to the screen and the $\frac{3}{8}$ " / 10 mm NPT inlet and outlet connections. The J0097B strainer provides a standard $\frac{1}{4}$ " / 6.35 mm sensing / gauge connection.

ORDERING INSTRUCTIONS

Refer to page 244 for the order form and ordering instructions.



PRODUCT LINE DRAWING

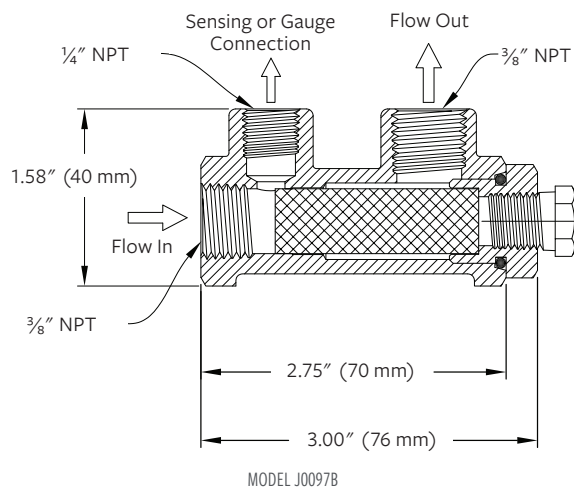

STANDARD MATERIALS

- Body: Stainless Steel 316
- Screen Retainer: Stainless Steel 316
- Screen (40 Mesh): Stainless Steel 316
- Screen Retainer Seal: Buna
- Blow Down Plug: Stainless Steel 316

MODELS J1521G & J1521M

Arion Strainers

PRODUCT OVERVIEW

The Arion series strainers are more suited to dirty water applications. The dirt is trapped on the inside of the double mesh screens and collects in the bowl. The double port construction of the housing prevents the particles from re-entering the flow stream.

The collected dirt can be flushed directly out to drain by opening the blowdown. The J1521G strainer has a glass collection bowl, while the J1521M strainer has a metal bowl. Standard pressure rating for the strainer is 232 psi / 16 bar. Body connections are 1/2" / 15 mm NPT and it comes complete with a 3/8" / 9.5 mm blowdown valve and a discharge tube.



PRODUCT LINE DRAWING

NO.	PART
1	Blowdown (Drain) Valve
2	Discharge Tube
3	Double Mesh 18-8 Stainless Steel Screens
4	'A' 1/2" NPT Inlet and Outlet Connections
5	Low Velocity Settling Zone
6	1/4" NPT Gauge Connections
7	Double Neck, Housing Directs Particles Onwards
8	Collection Bowl - Glass (Optional Brass)

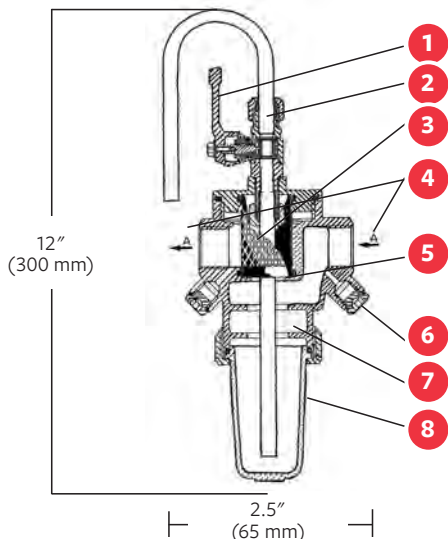

STANDARD MATERIALS

- Body: Brass
- Cap: Brass
- Screens: 18-8 SST (40 mesh optional; 80 mesh optional)
- Seals: Buna-N
- Packing: P.T.F.E.
- Bowls: Standard - Trogamid T (Glass); Optional - brass
- Nuts: Brass
- Drain Valve: Brass

ORDERING INSTRUCTIONS

Refer to page 244 for the order form and ordering instructions.

Additionally, include the following information for this product:

- some products

TECHNICAL SIZING & INFORMATION

TECHNICAL & SIZING INFORMATION

INTRODUCTION

Sizing and selection of the automatic control valve that will meet all of your system design and performance requirements is critically important. We offer the following guidelines and notes to provide a basic understanding of the operating principals and to assist in the selection process.

FULL AND STANDARD PORTS

We manufacture two distinct model series – 106 Full Port and 206 Standard Port valves. Model 206 series valves are similar to Model 106 series except that the seats are one standard pipe size smaller than the flange sizes. For example, a 6" / 150 mm 206-PG valve has a 4" / 100 mm seat diameter. The Model 206 is often a preferred selection when the flow ranges are suitable. Most sizes are also available in angle (A) pattern and valves larger than 6" / 150 mm are also available with the Single Rolling Diaphragm (S) technology.

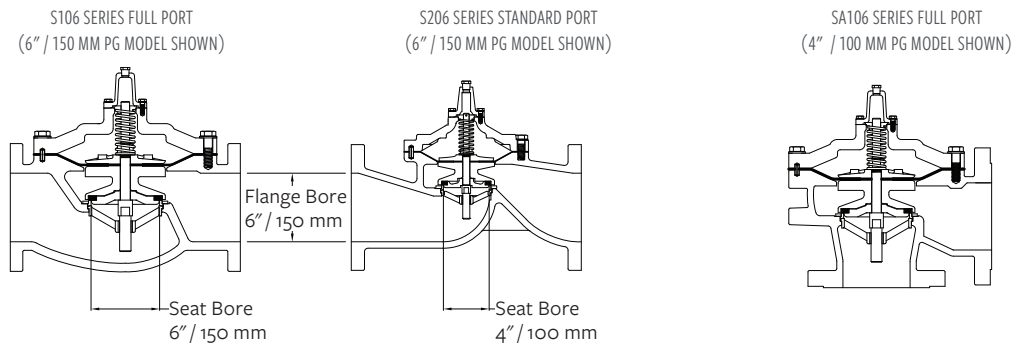

Guidelines for using the flow versus pressure drop curves:

- 106-412 106 Series Full Port, Globe Style Valves
- 106-413 A106 Series Full Port, Angle Style Valves
- 206-414 206 Series Standard Port, Globe Style Valves
- 206-414 A206 Series Standard Port, Angle Style Valves

CV AND KV FACTOR & THE STRAIGHT LINE

The flow through a fully open valve may be calculated using the formula:

IMPERIAL MEASURE

$$Q \text{ (USGPM)} = C_v \text{ (Valve Constant)} \cdot \sqrt{\Delta P \text{ (psi)}}$$

where the C_v is the flow in USGPM when there is a 1 psi pressure drop across a fully open valve.

From the Singer® performance curves, the straight lines indicate the flow vs. pressure drop through a fully open valve. The Y axis is drawn at the 1 psi pressure drop value. Consequently, the intersection between the flow curve and the Y axis represents the C_v factor for each valve size.

METRIC MEASURE

$$Q \text{ (L/s)} = K_v \text{ (Valve Constant)} \cdot \sqrt{\Delta P \text{ (bar)}}$$

where the K_v is the flow in l/s when there is a 1 bar pressure drop across a fully open valve.

Valves that open fully on low pressure drop require their control chambers (bonnets) to be vented to atmosphere. Commonly, altitude and pump control valves (BPC and DW) are vented to atmosphere and may be selected from the straight line performance curves.

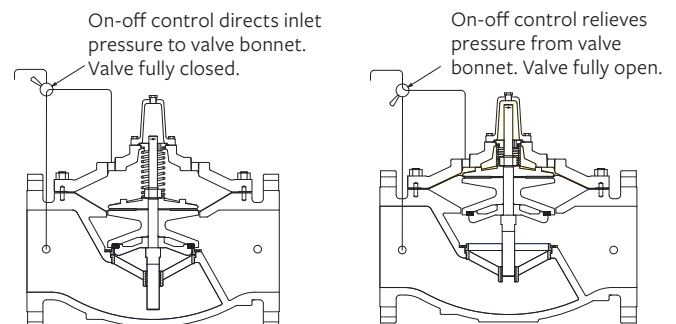

TECHNICAL & SIZING INFORMATION

DROOPING PORTION OF THE CURVES

As mentioned in the previous section, Cv and Kv Factor & the Straight Line, the straight lines represent the pressure drop for fully open valves.

Should the pressure drop across the valve be low (less than 10 psi / 0.7 bar) and the control chamber be connected to downstream, the flow through the valve will be less than when the control chamber is venting to atmosphere and the valve is fully open.

When the bonnet is at the same pressure as the downstream (e.g. the same pressure is on both sides of the diaphragm) there is no resulting opening force from the diaphragm. The force of the main spring and the weight of the inner valve (stem vertical) tend to close the valve.

The opening force results from the pressure drop (between upstream and downstream) acting on the seat area. Flow commences when the pressure drop is sufficient to overcome the force of the spring and the weight of the inner valve assembly. Increasing the pressure drop increases the opening force on the inner valve, permitting greater flow; at approximately 10 psi / 0.7 bar pressure drop the valve is fully open. The drooping portion of the curves represent how the flow increases as the pressure drop increases from zero.

WHEN ACTUAL FLOW IS LESS THAN THE VALUE SHOWN BY THE GRAPH

Usually, required flow is less than that shown on the curves—typically, pressure reducing valves. The curves show only the maximum flow available under a given pressure drop. When less than maximum flow is required, the valve will automatically open the required amount.

OPERATING RANGES

The letters C, I and M are industry standard designations for continuous, intermittent and momentary flows.

- C maximum for continuous flow
- I maximum for intermittent flow (peak flow for short duration)
- M maximum for momentary flow (such as relief valve)

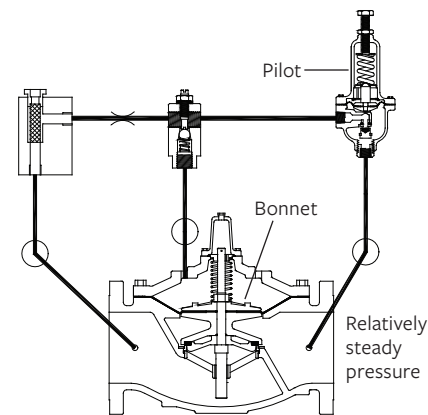
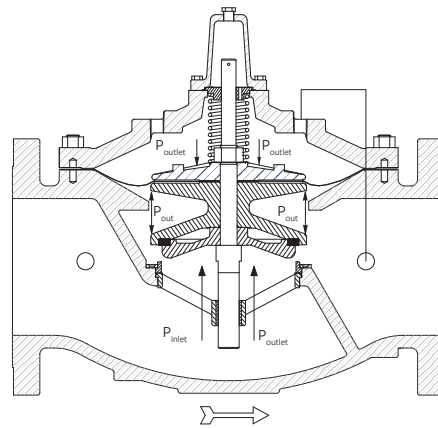

SINGER® MODEL 106-PR / 206-PR
PRESSURE REDUCING VALVE

- Relatively steady pressure downstream
- Varying inlet pressure
- Varying flow demand

TECHNICAL & SIZING INFORMATION

Flow vs. Minimum Pressure Drop – 106 Series (PG, PGX, PT / PTC, PGM)

Globe Body, Flat Diaphragm

Curve 106-412 (1/2" / 15 mm – 8" / 200 mm)

Straight Lines—Flow For a Fully Open Valve (Bonnet vented to atmosphere)
Curved Lines—Bonnet vented to downstream

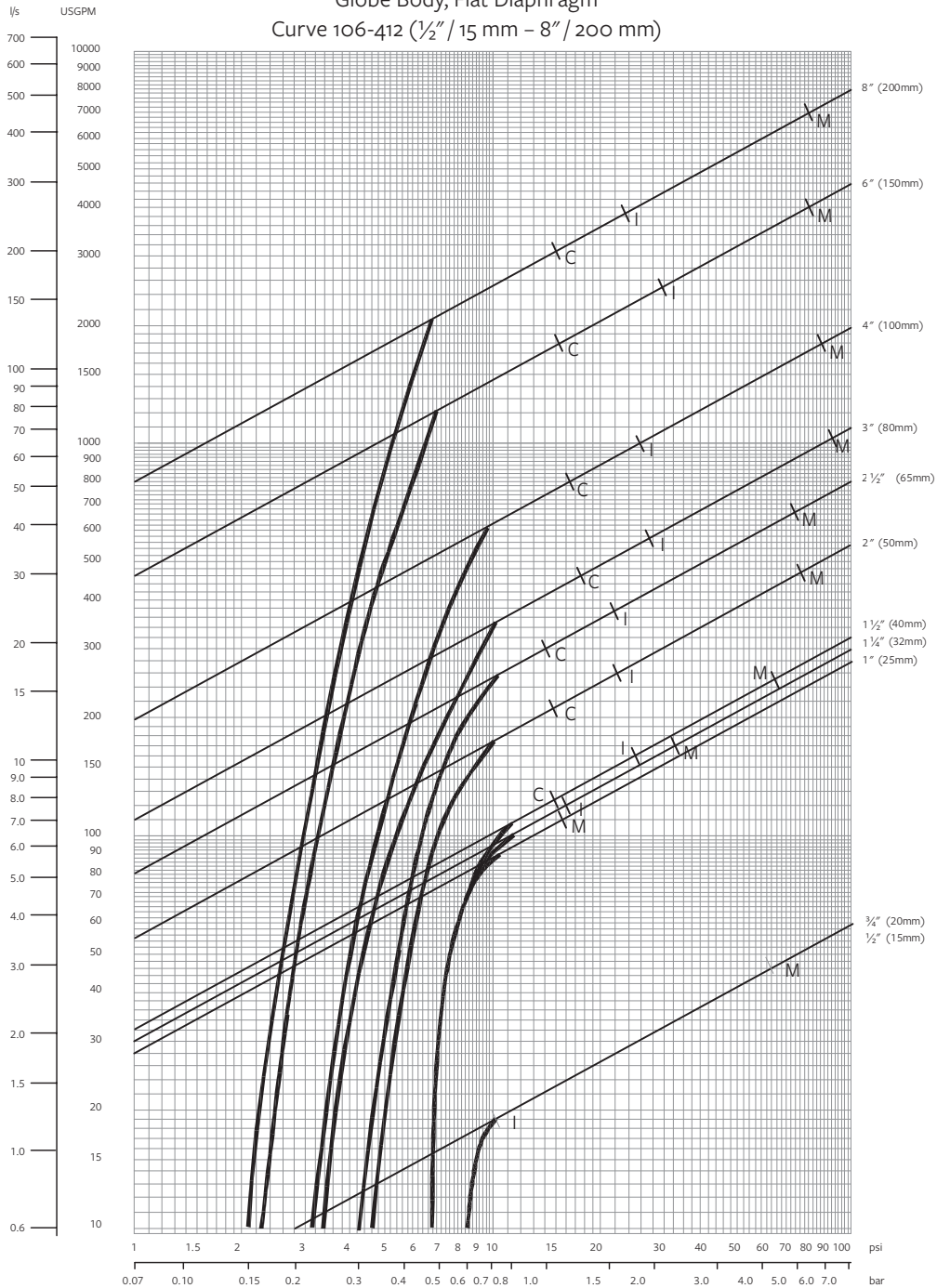

Minimum Pressure Drop

C = Continuous Service
20 ft/s / 6 m/s

I = Intermittent Service
25 ft/s / 7.5 m/s

M = Momentary Service
45 ft/s / 14 m/s

TECHNICAL & SIZING INFORMATION

Flow vs. Minimum Pressure Drop – 106 Series (PG, PGX, PT / PTC, PGM)
 Globe Body, Rolling Diaphragm
 Curve 106-412 (6" / 150 mm – 36" / 900 mm)

Straight Lines—Flow For a Fully Open Valve (Bonnet vented to atmosphere)
 Curved Lines—Bonnet vented to downstream

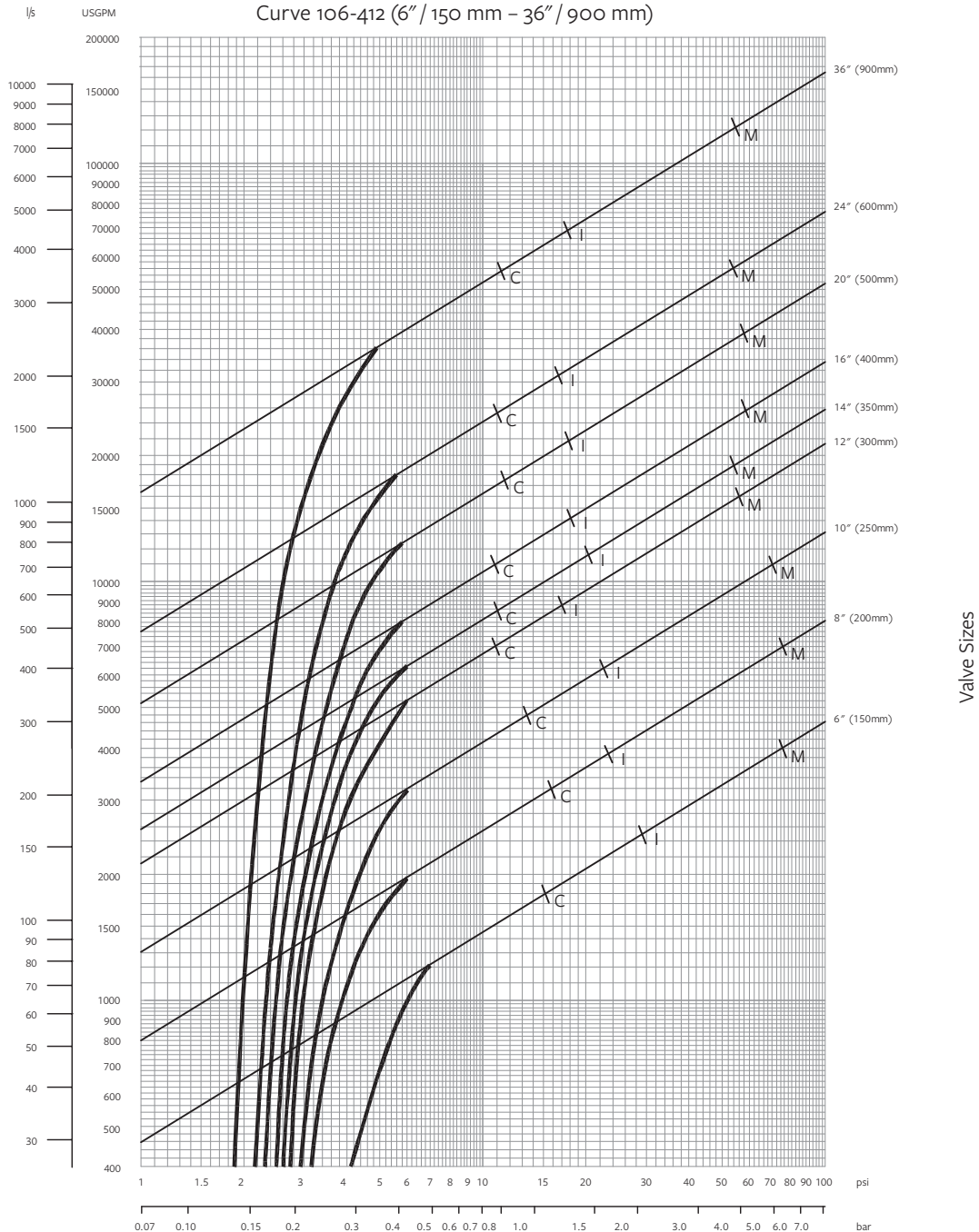

Minimum Pressure Drop

C = Continuous Service	I = Intermittent Service	M = Momentary Service
20 ft/s / 6 m/s	25 ft/s / 7.5 m/s	45 ft/s / 14 m/s

TECHNICAL & SIZING INFORMATION

Flow vs. Pressure Drop – 106 Series (PG, PGX, PT / PTC, PGM)

Angle Body, Flat & Rolling Diaphragm
Curve 106-413 (1" / 25 mm – 20" / 500 mm)

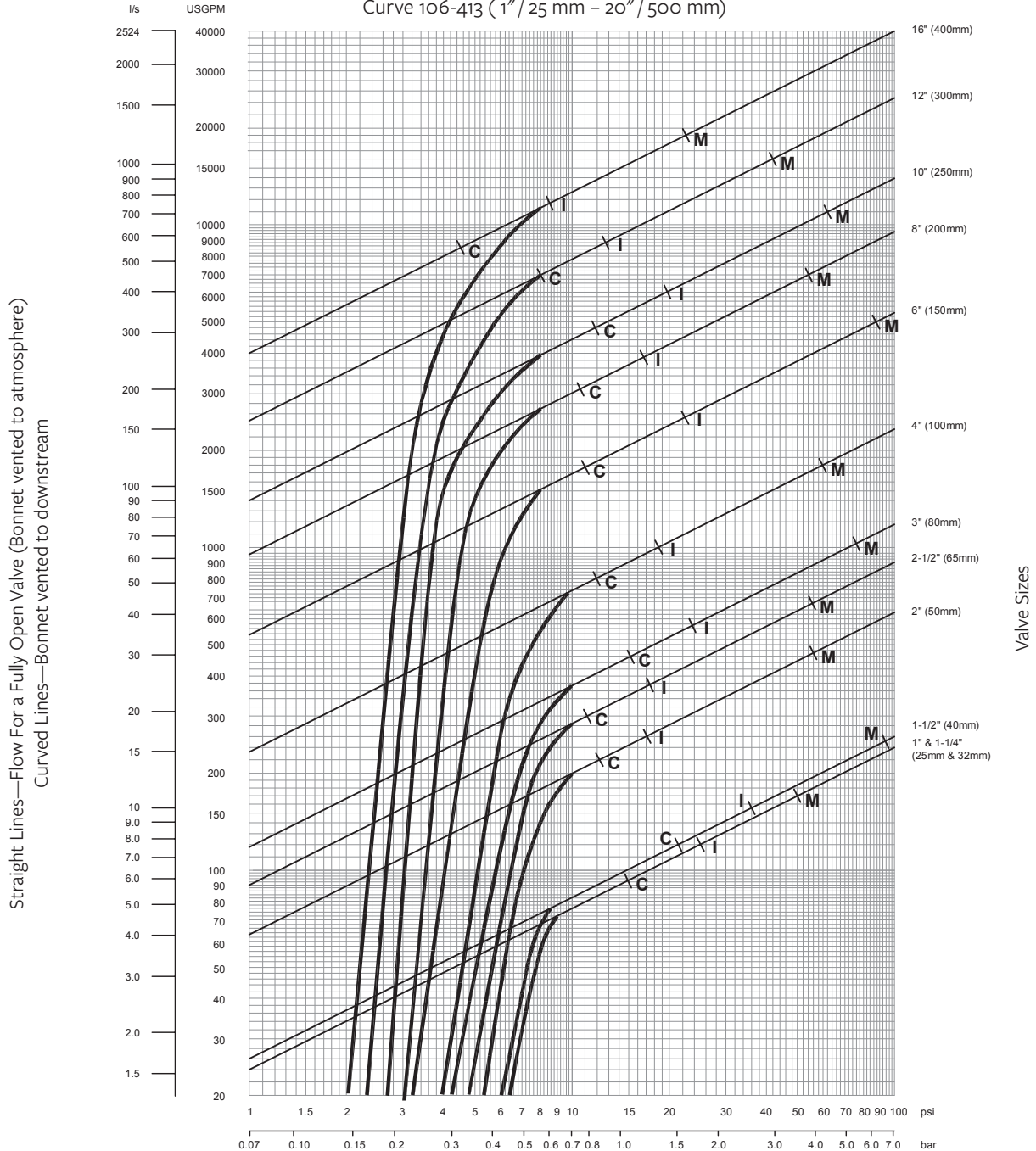

Straight Lines—Flow For a Fully Open Valve (Bonnet vented to atmosphere)
Curved Lines—Bonnet vented to downstream

Valve Sizes

Minimum Pressure Drop

C = Continuous Service
20 ft/s / 6 m/s

I = Intermittent Service
25 ft/s / 7.5 m/s

M = Momentary Service
45 ft/s / 14 m/s

TECHNICAL & SIZING INFORMATION

Flow vs. Pressure Drop – 206 Series (PG, PGX, PT / PTC, PGM)

Globe & Angle, Flat & Rolling Diaphragm

Bodies Curve 206-414 (3" / 80 mm – 40" / 1000 mm)

Straight Lines—Flow For a Fully Open Valve (Bonnet vented to atmosphere)
Curved Lines—Bonnet vented to downstream

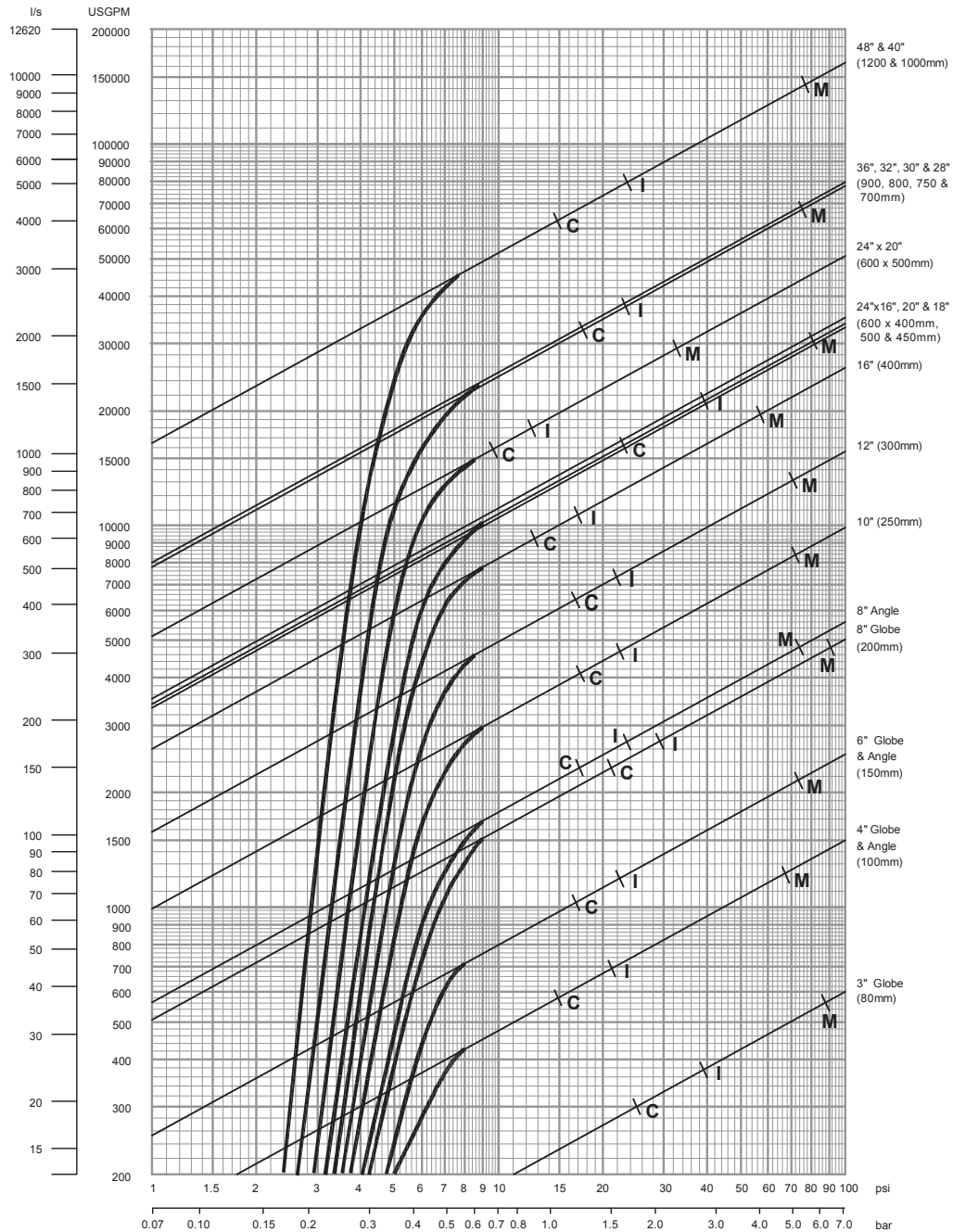

Valve Sizes

Minimum Pressure Drop

C = Continuous Service
20 ft/s / 6 m/s

I = Intermittent Service
25 ft/s / 7.5 m/s

M = Momentary Service
45 ft/s / 14 m/s

TECHNICAL & SIZING INFORMATION

Dynamic Lifter Sizing Graph Curve: 3" / 80 mm – 8" / 200 mm

Traditional relief valves for sewage are typically sized larger than a Singer® Dynamic Lifter due to opening forces being lost as the inner valve leaves the seat.

Benefits: Smaller size, smaller footprint and reduced cost

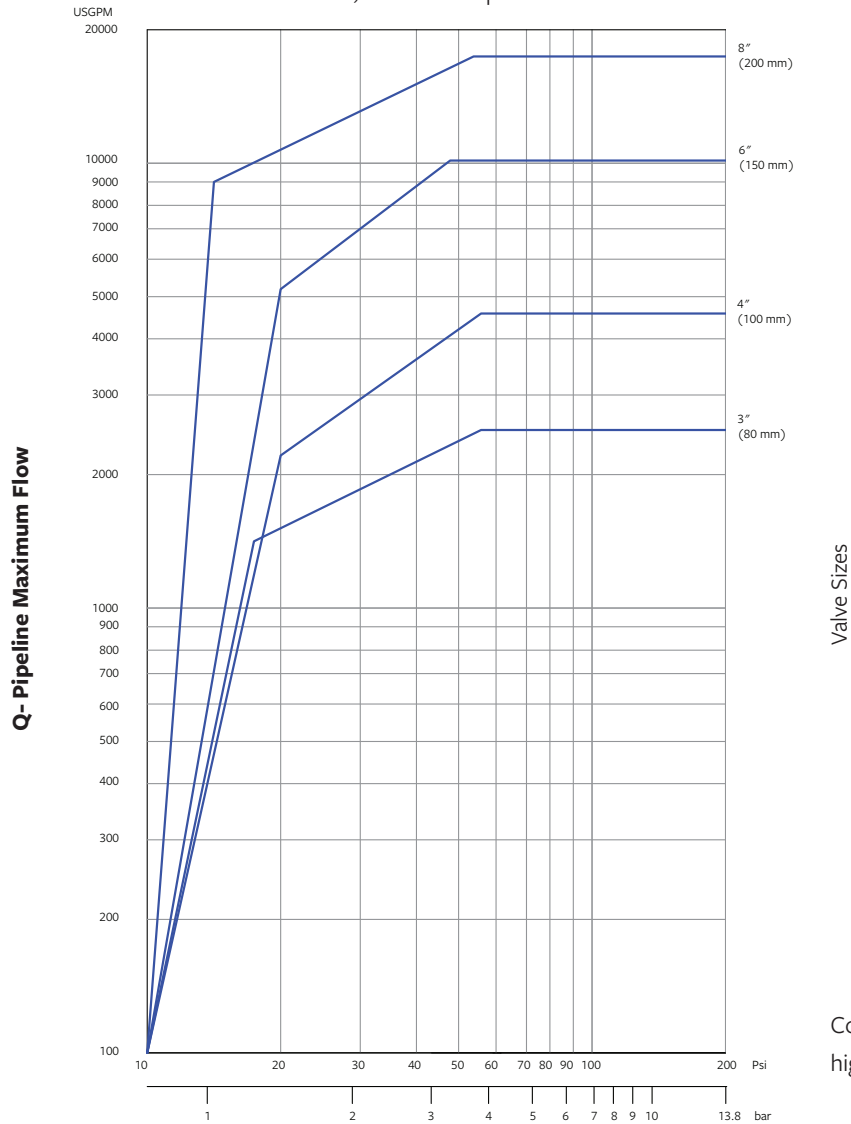

Consult us for higher pressures.

ΔP - Minimum Pressure Drop Across Dynamic Lifter

Examples of valve size selection

- Relief setting 80 psi / 5.5 bar - discharge to atmosphere: Max. flow in main pipeline 1,200 USGPM / 75.7 l/s - Find intersect of 80 psi / 5.5 bar ΔP and 1200 USGPM / 75.7 l/s flow. Select next larger size Dynamic Lifter, e.g., 3" / 80 mm size.
- Relief setting 55 psi / 3.8 bar - discharge 20 psi / 1.38 bar back pressure: Max. flow in main pipeline 4,000 USGPM / 252.4 l/s
Find intersect of 55 psi - 20 = 35 psi / 2.4 bar ΔP and 4000 USGPM / 252.4 l/s flow. Select next larger size Dynamic Lifter, e.g., 6" / 150 mm size.

Note:

- If the discharge was to atmosphere, ΔP = 55 psi / 3.8 bar and 4" / 100 mm size would be selected.
- This graph is based on current practice for standard applications. It is intended to be a guide only and no selection guarantee is implied or intended.

TECHNICAL & SIZING INFORMATION

Flow vs. Pressure Differential

Model 106 Series (PG-AC, PGX-AC, PT-AC, PGM-AC) – Full Port, Globe Body, Flat / Rolling Diaphragm
Anti-Cavitation Valve Curve 106-415 (1" / 25 mm – 36" / 900 mm)

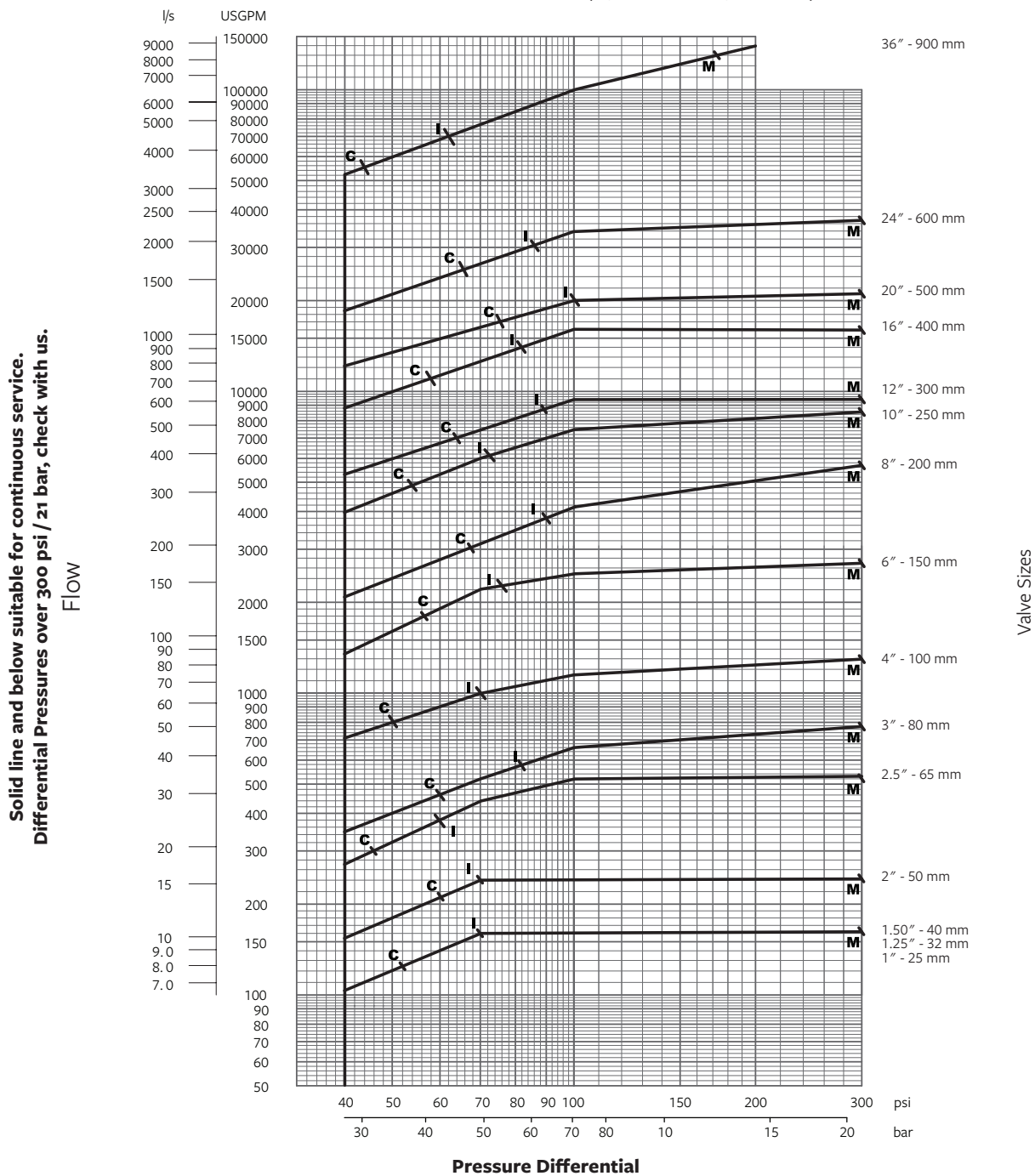

TECHNICAL & SIZING INFORMATION

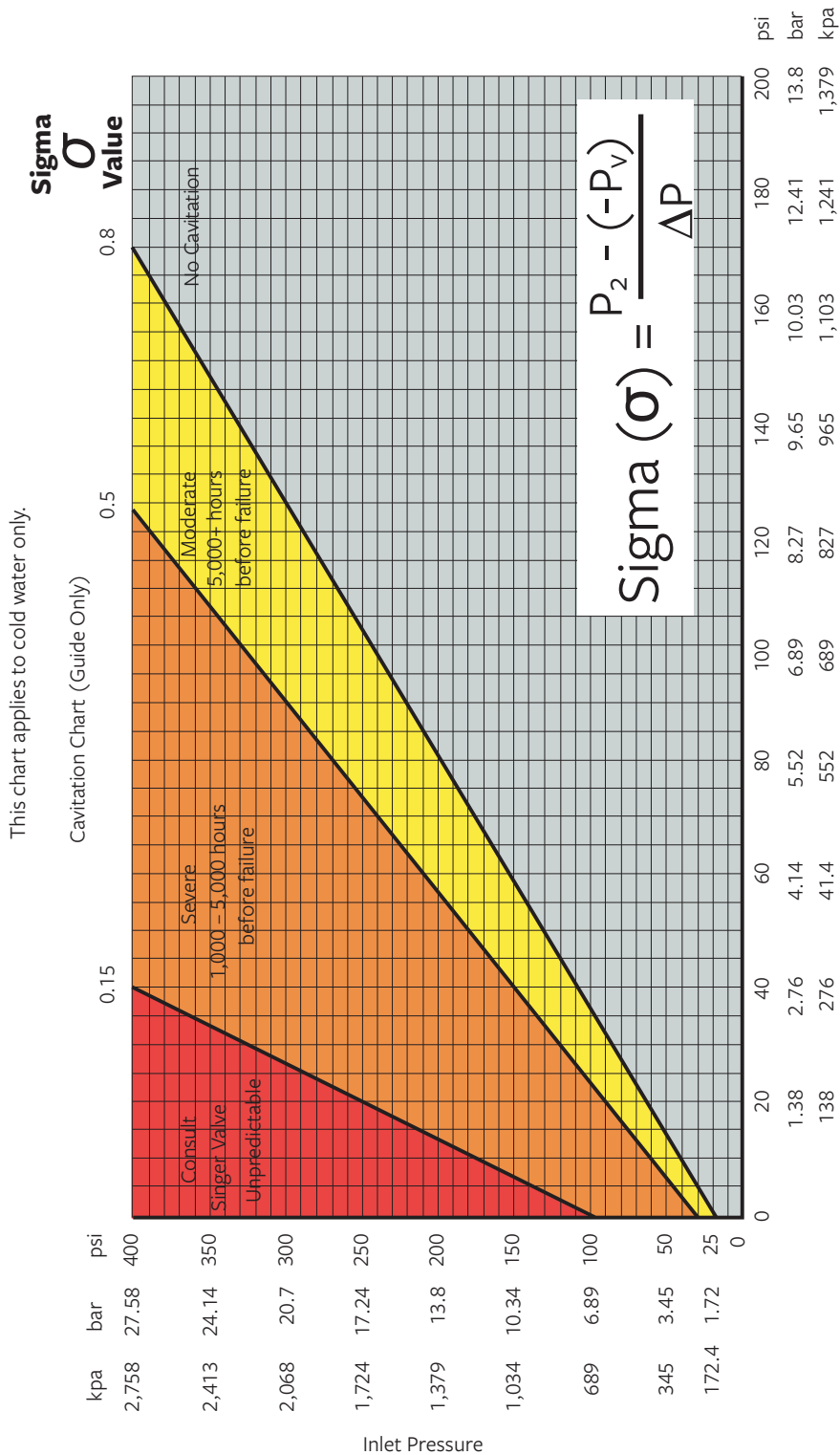

FLANGE DIMENSIONS— DUCTILE IRON VALVES

STANDARD: ANSI B16.42 - 1998 - CLASS 150 AND 300

Pressure Class	DIAMETER OF FLANGE		DIAMETER OF BOLT CIRCLE		NUMBER OF BOLTS		DIAMETER OF BOLT HOLES	
	150#	300#	150#	300#	150#	300#	150#	300#
1.5	5.00	6.12	3.88	4.50	4	4	5/8"	7/8"
2	6.00	6.50	4.75	5.00	4	8	3/4"	3/4"
2.5	7.00	7.50	5.50	5.88	4	8	3/4"	7/8"
3	7.50	8.25	6.00	6.62	4	8	3/4"	7/8"
4	9.19	10.19	7.50	7.88	8	8	3/4"	7/8"
6	11.19	12.69	9.50	10.62	8	12	7/8"	7/8"
8	13.50	15.00	11.75	13.00	8	12	7/8"	1"
10	16.00	17.50	14.25	15.25	12	16	1"	1 1/8"
12	19.00	20.50	17.00	17.75	12	16	1"	1 1/4"
14	21.00	23.00	18.75	20.25	12	20	1 1/8"	1 1/4"
16	23.50	25.50	21.25	22.50	16	20	1 1/8"	1 3/8"
18	25.00	28.00	22.75	24.75	16	24	1 1/4"	1 3/8"
20	27.50	30.50	25.00	27.00	20	24	1 1/4"	1 3/8"
24	33.00	36.00	29.50	32.00	20	24	1 3/8"	1 5/8"
30	38.75	43.00	36.00	39.25	28	28	1 3/8"	2"
36	46.50	50.00	42.75	46.00	32	32	1 5/8"	2 1/4"

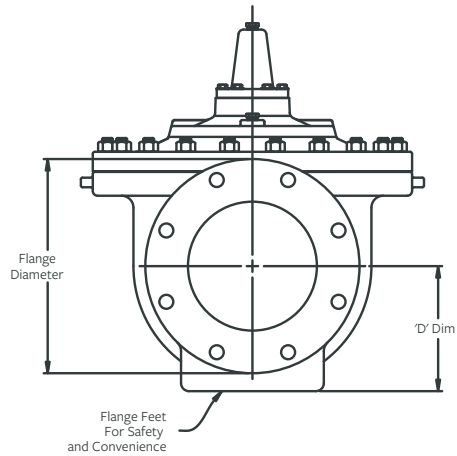

STANDARD: ISO 7005-2 - 1998

NOMINAL PIPE SIZE	DIAMETER OF FLANGE				DIAMETER OF BOLT CIRCLE				DIAMETER OF BOLT HOLES				NUMBER OF BOLTS			
	PN-10	PN-16	PN-25	PN-40	PN-10	PN-16	PN-25	PN-40	PN-10	PN-16	PN-25	PN-40	PN-10	PN-16	PN-25	PN-40
40	155	155	155	155	110	110	110	110	19	19	19	19	4	4	4	4
50	152	152	152	152	125	125	125	125	19	19	19	19	4	4	4	4
65	178	178	178	178	145	145	145	145	19	19	19	19	4	4	8	8
80	200	200	200	200	160	160	160	160	19	19	19	19	8	8	8	8
100	233	233	260	260	180	180	190	190	19	19	23	23	8	8	8	8
150	285	285	310	310	240	240	250	250	23	23	28	28	8	8	8	8
200	343	343	381	381	295	295	310	320	23	23	28	31	8	12	12	12
250	406	406	445	445	350	355	370	385	23	28	31	34	12	12	12	12
300	483	483	483	520	400	410	430	450	23	28	31	34	12	12	16	16
350	533	533	584	584	460	470	490	510	23	28	34	37	16	16	16	16
400	597	597	648	648	515	525	550	585	28	31	37	40	16	16	16	16
500	699	699	775	775	620	650	660	670	28	34	37	43	20	20	20	20
600	838	838	838	915	725	770	770	795	31	37	40	49	20	20	20	20
700	895	910	960	995	840	840	875	900	31	37	43	48	24	24	24	24
800	1,015	1,025	1,085	1,140	950	950	990	1,030	34	40	49	56	24	24	24	24
900	1,115	1,125	1,185	1,285	1,050	1,050	1,090	1,170	34	40	49	56	28	28	28	28

Note: ISO flange diameters may vary slightly from the standard, as the flange bolt pattern is drilled on an ANSI valve flange.

ENGINEERING NOTES

In this section, you will find additional engineering notes for the main valves and also the anti-cavitation valve.

MAIN VALVES DATA (US & METRIC UNITS & ISO)

ENGINEERING NOTES:

- Drilled as per ANSI B16.42 or threaded as per ANSI B1.20.1.
- ANSI flanges drilled to ISO 7005-2 - 1998 / BS54504 PN 10, 16, 25, or 40, or threaded BSPT.
- Class 150 machined flat faced / Class 300 machined raised faced.
- Castings are based on ANSI Class 150 or Class 300 standards.
- For conditions where working pressures exceed 300 psi / 20.7 bar, consult with us.
- Allow $\frac{1}{8}$ " / 3 mm for machining tolerance.
- Allow one to three feet for installation and maintenance clearances. Consult us for certified dimensions.
- Preferred method of stem installation is vertically; on valves 10" / 250 mm and larger the vertical installation method is mandatory.
- Add a minimum 6" / 150 mm on one side, for Pilot System.

ANTI-CAVITATION DATA

106-AC / 206-AC (206 IN LARGE VALVE SIZES ONLY)

As a guide, if downstream pressure of an automatic control valve is less than 35% of the inlet pressure, there is a risk of cavitation damage occurring. Use 106-415 to select the valve size.

Cavitation chart on page 240 can also be used to determine if a valve is cavitating. Plot the maximum inlet pressure against the minimum outlet pressure.

- If this plotted point is to the right of the 0.8 line (e.g. you are in the "No Cavitation" zone) then use performance curves from chart 106-412, 106-413 and 106-414 on pages 234 - 237 to select the valve size.
- If this plotted point is to the left of the 0.8 line then use performance curves 106-415 to select the valve size.

Refer to Singer® Performance Curves and Cavitation Charts in the Technical & Sizing Information section page 231 or contact us.

ENGINEERING NOTES

HOW TO ORDER

Order forms can be found on page 244-246.

FAX/EMAIL: Complete the order form, and fax OR email it to your local Singer® Sales Representative. Refer to singervalve.com/find-a-rep for sales representative contact information.

WEBSITE: Complete a Request a Quote form on singervalve.com AND attach a scanned PDF copy of the completed order form.

When completing your order form, please include as much detail as possible.

Specifically, always include the following:

- Product model number
- Globe or angle pattern
- End connections
- Valve size

Please note that some products will require additional information, refer to the specific product page sheet for clarification.

PARTS AND REPAIR KITS

To order Parts and Repair Kits, please complete the order form and include the following information:

- Valve model
- Revision
- Valve size (inches or millimeters)
- Maximum inlet pressure (psi or bar)
- Serial number

This information can be found on the identification plate on the product.

SINGER VALVE INC.		REV.
MODEL		
SIZE	IN.	MAX INLET PSI
SER. NO		

Identification Plate Sample

Essential information required includes valve function, material, pressure rating, end connections, pilot controls and control adjustment ranges.

TO SPECIFY SINGER® PRODUCTS

Singer® Specifications are set up in a modular fashion.

1. Select the product you require. Refer to the specification which accompanies that product.
2. Refer to the Main Valves section (page 11). Add the specification for the Singer® Main Valve Body selected.
3. Refer to the Main Valves Options section (page 62). Add the addendum to your Main Valve specification (if applicable).
4. Refer to the Pilots & Accessories section (page 207). Add the specification for the Singer® pilot and/or accessory selected (if applicable).

CONTROL VALVE & ACCESSORIES ORDER FORM

EMAIL OR Fax to your local Singer® Sales Representative. Refer to singervalue.com/find-a-rep for contact information.

ORDER/QUOTATION INFORMATION

PROJECT NAME: _____
 REFERENCE #: _____
 SINGER REP: _____
 P O #: _____

ITEM NO. ON PO: _____
 QUANTITY: _____
 DATE APPROVED: _____
 DATE ORDERED: _____
 REQUESTED DELIVERY: _____

ORDER DESCRIPTION

MODEL# (I.E. PR, RPS): _____
 SERIES 106 206 INCHES MM
 VALVE SIZE: _____
 FLUID BEING HANDLED: _____

VALVE PATTERN

GLOBE PATTERN ORIENTATION (SIDE VIEWS SHOWN)

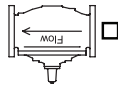
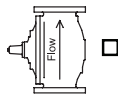

NOTE: HORIZONTAL STEM - 106 AVAILABLE UP TO 8" ONLY.
 206 AVAILABLE UP TO 10" ONLY. CONSULT FACTORY.

APPLICATION DETAILS

USGPM OR L/S
 PSI OR BAR (KG/CM²)
 OTHER - PLEASE SPECIFY: _____

FLOW RATE

MINIMUM: _____
 NORMAL: _____
 MAXIMUM: _____

DIFFERENTIAL PRESSURE RANGE

INLET: _____ OUTLET: _____
 INLET: _____ OUTLET: _____
 INLET: _____ OUTLET: _____

FLUID TEMPERATURE RANGE

MINIMUM: _____
 NORMAL: _____
 MAXIMUM: _____

END CONNECTIONS

ANSI FNPT ANSI 150 ANSI 300 BSPT
 ANSI DRILLED TO PN10 ANSI DRILLED TO PN16
 ANSI DRILLED TO PN25 ANSI DRILLED TO PN40
 OTHER - PLEASE SPECIFY: _____

PILOT SYSTEM ORIENTATION

ANGLE PATTERN ORIENTATION (SIDE VIEWS SHOWN)

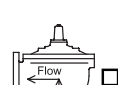
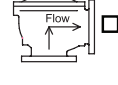
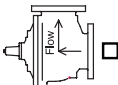

STANDARD

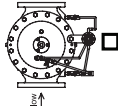

OPPOSITE (TOP VIEWS SHOWN)

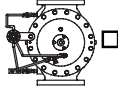

ELECTRICAL (WHERE APPLICABLE)

SOLENOID VOLTAGE: _____
 PILOT RANGE(S): _____
 ENERGIZE TO: OPEN OR CLOSE MAIN VALVE
 NUMBER OF LIMIT SWITCHES: _____
 ACTUATION POSITIONS: _____
 CONTACTS: SPDT OR DPDT
 STANDARD POWER-FAILURE MODE IS FAIL AT LAST POSITION
 OR FAIL OPEN ON POWER FAILURE
 OR FAIL CLOSED ON POWER FAILURE
 SOURCE OF SETPOINT SIGNAL (4-20mA): _____
 SOURCE OF SET PROCESS VARIABLE SIGNAL: _____
 OPTIONAL EXPLOSION PROOF HOUSING
 OPTIONAL NEMA 4X CONTROL PANEL ENCLOSURE
 OPTIONAL TOUCH SCREEN OPERATOR INTERFACE

MAIN VALVE OPTIONS

RECLAIMED WATER
 EXTERNAL SPRING LIFT
 GROOVED ENDS
 INTERNAL DROP CHECK
 ANTI CAVITATION TRIM
 X107 POSITION INDICATOR
 X129 LIMIT SWITCH INDICATOR
 X156 ANALOG POSITION TRANSMITTER
 NO YELLOW METAL UPGRADE
 DELRIN STEM SLEEVE
 OXY NITRIDE STEM

PILOTS AND ACCESSORIES

PILOT SPRING RANGE: _____
 REQUIRED OPERATING RANGE: _____
 PILOT UTILIZED: _____
 MODEL J0097A STRAINER
 MODEL J0098A STRAINER
 ARION MODEL J1521G STRAINER
 ARION MODEL J1521M STRAINER

OTHER INFORMATION

OTHER

CONTROLS FLOW
 IN OUT OF RESERVOIR

SPECIAL NOTES

SPI-MV ORDER FORM

MODEL NUMBER:

SINGLE POINT INSERTION
ELECTROMAGNETIC FLOW METER
IOM: A-0985A-SPI-MV

SPI - MV - _____ - _____ - _____ - _____

SELECTION AND CONFIGURATION

SPI-MV- XXX - XX - X - X - X

VALVE SIZE

- 003 - 3" 106
- 004 - 4" 106
- 006 - 6" S106
- 008 - 8" S106
- 010 - 10" S106
- 012 - 12" S106
- 016 - 16" S106
- 020 - 20" S106
- 024 - 24" S106
- 028 - 28" S206
- 036 - 36" S106

SUPPLY VOLTAGE

- AC - 90-265VAC, 45-66 Hz (25VA)
- DC - 10-35 VDC (21W)
- BT - BATTERY POWER (0.5W)

****NOTE: BATTERY ONLY AVAILABLE IN LOCAL CONVERTOR**

PILOT SYSTEM ORIENTATION

CONVERTER

- L - LOCAL CONVERTER (IP67)
- P - PANEL-MOUNTABLE CONVERTER (IP65)

CABLE LENGTH

- A - 5 FEET
- B - 10 FEET
- C - 20 FEET (STANDARD)
- D - OTHERS: _____

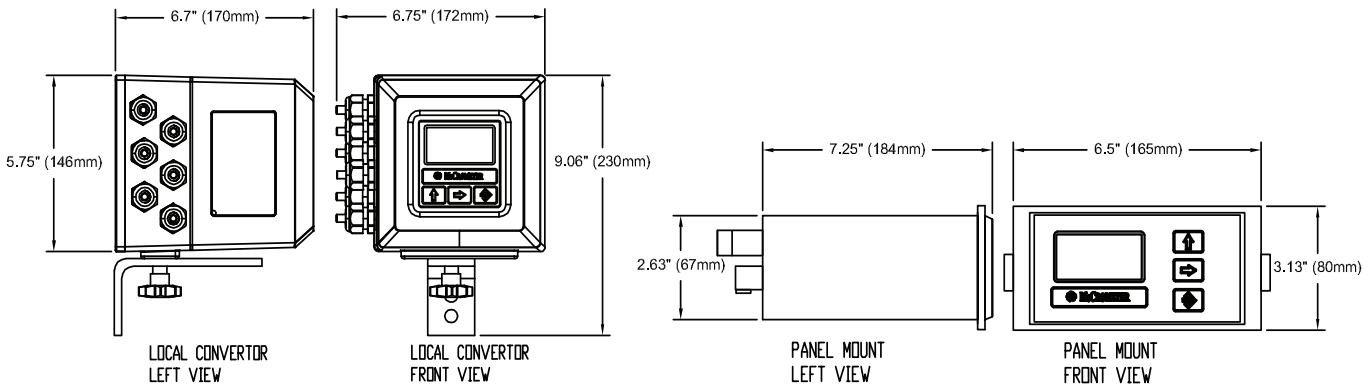

TRANSMITTER/CONVERTER CONFIGURATION

* OPTIONAL

- 1 Flow Output Range: _____
- 2 Display Units: _____
- * 3 Totalizer Pulse Output: _____
- * 4 Alarms: _____

AVAILABLE ALARM OUTPUTS

- SIGN (S): Indicates Flow Direction
- EMPTY PIPE (EP): Indicated Empty Pipe
- OVERFLOW (O): Indicated Out of Range
- HARDWARE ALARM (H): Cumulative Alarm Output; Interrupt Coils, Empty Pipe, Measure Error

ADDITIONAL NOTES:

This quotation/submittal is for valve(s) described above and reflects our understanding of functions required. We assume no responsibility for meeting all stated or implied requirements beyond functions listed above. If above does not adequately describe functions/operation of above products, please ask for a more comprehensive description and mention areas where above description is deficient.

420-DC / 420-AC ORDER FORM

MODEL NUMBER:

SINGER MODEL 420DC
 MOTORIZED PILOT ACTUATOR
 IOM: A-0984E

420 - DC - ____ - ____ - ____ - ____

SELECTION AND CONFIGURATION

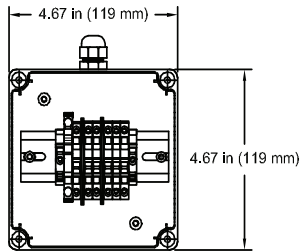
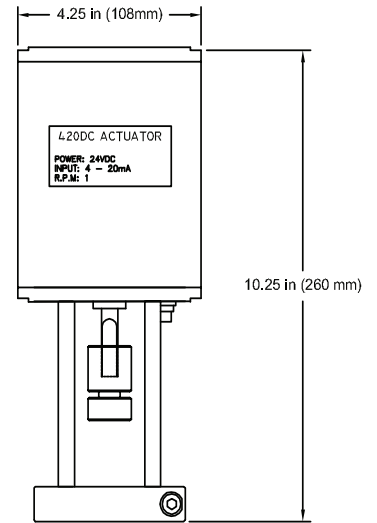
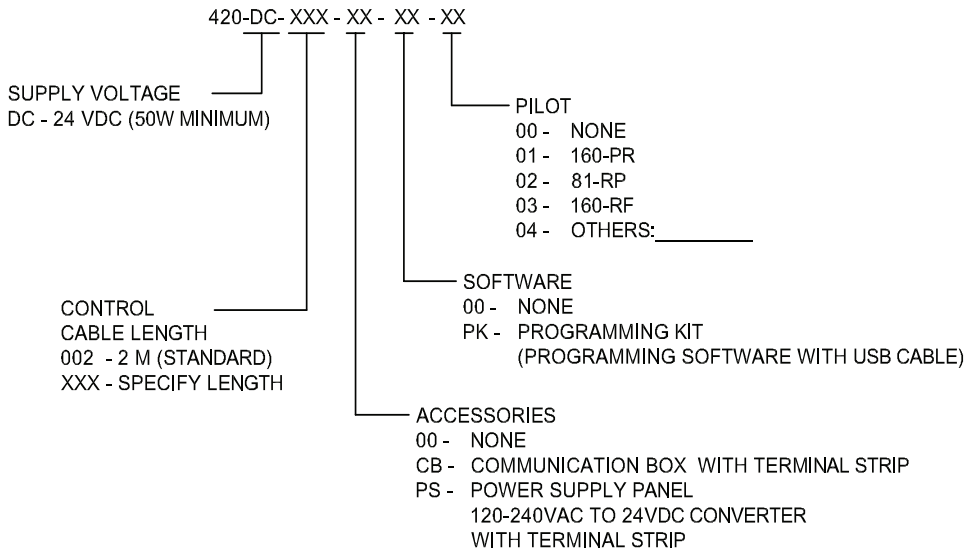

CB - COMMUNICATION BOX
 FULLY WIRED WITH CONTROL CABLE
 ENVIRONMENTAL RATING: IP67 (NEMA 4,4X,6)

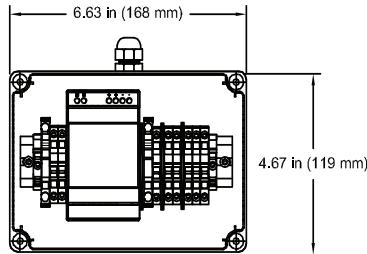

PS - POWER SUPPLY PANEL
 120-240VAC TO 24VDC CONVERTER
 FULLY WIRED WITH CONTROL CABLE
 ENVIRONMENTAL RATING: IP67 (NEMA 4,4X,6)

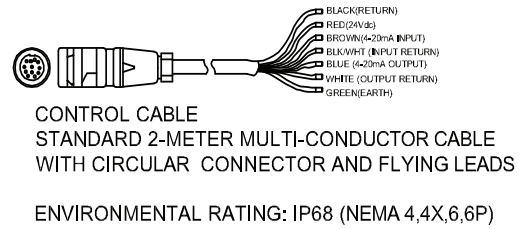

FACTORY CALIBRATION SERVICE

***OPTIONAL**

- 1 Pilot Range: _____
- * 2 Calibration Range:
 Minimum setpoint at 4.0 mA: _____
 Maximum setpoint at 20.0 mA: _____
- * 3 Failure Mode: STOP FAIL TO MINIMUM SETPOINT
 (on loss of signal) FAIL TO MAXIMUM SETPOINT

NOTE: IF A CALIBRATION RANGE IS NOT SPECIFIED, THE ACTUATOR WILL BE
 FACTORY CALIBRATED TO THE FULL PILOT SPRING RANGE.

ADDITIONAL NOTES:

This quotation/submittal is for valve(s) described above and reflects our understanding of functions required. We assume no responsibility for meeting all stated or implied requirements beyond functions listed above.
 If above does not adequately describe functions/operation of above products, please ask for a more comprehensive description and mention areas where above description is deficient.

SINGER VALVE INC. GLOBAL OFFICES



CANADA HEAD OFFICE

12850 – 87th Avenue
Surrey, BC V3W 3H9
Canada

Tel: 604.594.5404
Fax: 604.594.8845
Toll Free Fax (Canada & USA):
1.833.367.6835
✉ singer@muellerwp.com

USA OFFICE

Singer Valve
620 Industrial Drive SW
Cleveland, TN 37311

Toll Free (USA):
1.833.367.6835
✉ singer@muellerwp.com

UNITED ARAB EMIRATES OFFICE

Mueller Middle East FZE
Q4-031
Sharjah Airport International Free Zone
PO Box 122416
Sharjah, UAE

Tel: +971.6.526.0270
✉ mmesales@muellerwp.com

COLOMBIA OFFICE

Singer Latin America
Carrera 49A, #48 Sur 100
Local 102
Envigado, Colombia

Tel: +57.310.419.4165
✉ pegan@muellerwp.com

MALAYSIA OFFICE

SVM Water Controls Sdn. Bhd.
No 6, Jalan MJ 4, Medan Maju Jaya,
Batu 7, Jalan Kelang Lama
46200 Petaling Jaya
Selangor Darul Ehsan, Malaysia

Tel: 603.7784.4043 / 4044
Fax: 603.7781.8312
✉ svmwc@svm.com.my

CHINA OFFICE

Singer Valve (Taicang) Company Ltd.
No.88 East Dalian Road,
Taicang, Jiangsu, China

Tel: 86.512.5320.6188
Fax: 86.512.5320.6099
✉ lijun@muellerwp.com

SINGER®

a **MUELLER** brand

LET US PROVIDE YOU A SOLUTION

Connect with us today.

singervalue.com

Canada | USA | Columbia | UAE | Malaysia | China



For more information about us or to view our full line of water products, please visit www.singervalue.com or call Singer® customer service at 833.367.6835.

Mueller refers to one or more of Mueller Water Products, Inc. a Delaware corporation ("MWP"), and its subsidiaries. MWP and each of its subsidiaries are legally separate and independent entities when providing products and services. MWP does not provide products or services to third parties. MWP and each of its subsidiaries are liable only for their own acts and omissions and not those of each other. MWP brands include Mueller®, Echologics®, Hydro Gate®, Hydro-Guard®, HYMAX®, Jones®, Krausz®, Mi.Net®, Milliken®, Pratt®, Singer®, and U.S. Pipe Valve & Hydrant. Please see muellerwp.com/brands and krauszusa.com to learn more.

Copyright © 2019 Mueller SV, Ltd. All Rights Reserved. The trademarks, logos and service marks displayed in this document are the property of Mueller Water Products, Inc., its affiliates or other third parties. Products marked with a section symbol (§) are subject to patents or patent applications. For details, visit www.mwppat.com. These products are intended for use in potable water applications. Please contact your Mueller Sales or Customer Service Representative concerning any other application(s).

F 13871 3/19

MUELLER